

TD End-Suction Pumps

One of the broadest ranges of pumps available from any British manufacturer, with discharge sizes from 32 mm to 250 mm.

Widest choice of materials of construction and options to suit many industrial and building services specific requirements. Stainless steel pumps built from stock components.

Competitively priced and manufactured from components held in stock, with reliable prompt deliveries.

Capable of handling clean water, seawater, solvents, chemicals and other liquids with similar properties.

All pumps are manufactured strictly to **ISO 9001** quality control standards



Applications

- Water supply
- Cooling water
- Air conditioning
- Heating circulation
- Industrial liquids and chemicals
- Seawater
- Oils, solvents and process liquids
- Drinking and potable water
- Aqua-culture
- Electrophoretic paint

Operating data

Flow rates up to 300 l/sec
Head up to 160 metres
Temperature -20°C to $+150^{\circ}\text{C}$

Construction

Horizontal single stage end-suction pump with performance and key dimensions in accordance with DIN 24255 standard. The back-pull-out construction allows the pump to be dismantled without disturbing the suction and discharge pipework. Impellers are fully shrouded closed design, with double curvature vanes for optimum efficiency and good suction performance. Vortex design semi-open impellers are also available on some sizes.

Electric motors

Apex TD pumps are supplied bare shaft or with a TEFC IP55 electric motor. Alternative motors including Eexd flameproof motors are readily available.

Materials

The pump pressure containing parts are cast in a variety of materials, selected to suit the working pressure of the pump, and to be compatible with the liquid being handled. Available materials are:

- Cast iron
- Ductile iron
- Cast 316 Stainless steel
- Cast bronze
- Cast steel
- Specialist steels eg Duplex, Hastalloy

Flanges

Standard flanges are drilled to the British Standard BS4504, with pressure rating to suit the specific application:

BS4504 PN16	16 bar working pressure
BS4504 PN25	25 bar working pressure
BS4504 PN40	40 bar working pressure

ANSI standard flanges drilled to 150 lb or 300 lb ratings and all other standards are available on request.

Seals

A Packed gland seal or single mechanical seal is supplied as standard. Double mechanical seals and cartridge seals can be fitted to suit the application and to meet customers' preferences.

New Features of the TD pump range

Quality Control....

Every pump produced by Apex is manufactured strictly to ISO 9001 quality control procedures, and complies with the most rigorous documentary requirements of demanding customers.

More sizes....

New sizes are continually being added to the range, and with the recent introduction of the 200 mm and 250 mm discharge size pumps, and with motor powers up to 160 kW, the TD pump range is one of the most comprehensive ranges of close coupled pumps available from any pump manufacturer today. Now also available in In-Line Vertical configuration.

Larger stock....

Our policy of stocking large quantities of finished machined component parts, ready for immediate assembly, enables us to provide a fast delivery of complete pumps and spare parts, and has earned the company its good reputation for reliable delivery.

Specialist materials....

Apex carry large stocks of cast stainless steel pump components, and operate fast-track manufacture of specialist materials such as Duplex stainless steel and Hastalloy, backed by full materials certification and traceability.

Higher Pressures....

Pumps required to operate in tall buildings, and in certain industrial processes, need to operate at high working pressures. For these applications, Apex Pumps offer the TD range of close coupled pumps in cast steel, with flanges to BS4504 PN40.

Wide Choice of options....

Virtually any mechanical seal, cartridge seal or packed gland arrangement, with flush, quench or independent circulation system is possible with the Apex TD pump range. Modular construction enables the pump to be engineered using standard stock components wherever possible, and our in-house CNC machining facilities can quickly produce any special parts against tight deadlines.

Competitive Prices....

As a specialist manufacturer of centrifugal pumps, all Apex products are designed to be highly competitive without compromise to quality and good engineering practice.

....Benefit

The in-house engineering capability, attention to quality control and testing facilities make Apex the preferred choice for many high specification projects.

....Benefit

Greater choice results in a better hydraulic selection, optimised operating efficiency and lower power consumption. Now with 42 pump sizes to the Apex TD range, a cost-effective and properly engineered solution can be provided for most industrial pumping applications.

....Benefit

Quick delivery is appreciated by users and pump distributors alike, and makes Apex Pumps the first choice for replacement of existing pumps of other makes.

....Benefit

Industrial applications are increasingly specifying stainless steel pump materials in recognition of the environmental and economic benefits. Apex Pump's investment in stainless steel stock parts, provides users with a standard pump to the highest specifications.

....Benefit

The TD pump in cast steel provides a cost effective solution to what would otherwise be a specialist pump application. Many component parts will be shared with other TD pumps, providing spares interchangeability throughout the site.

....Benefit

Pump users benefit by the broad engineering experience at Apex, and our familiarity with difficult applications and demanding duties.

....Benefit

Apex fully supports its pump distributor network and customers by providing cost effective solutions to pumping problems.

TD range charts 50 hz

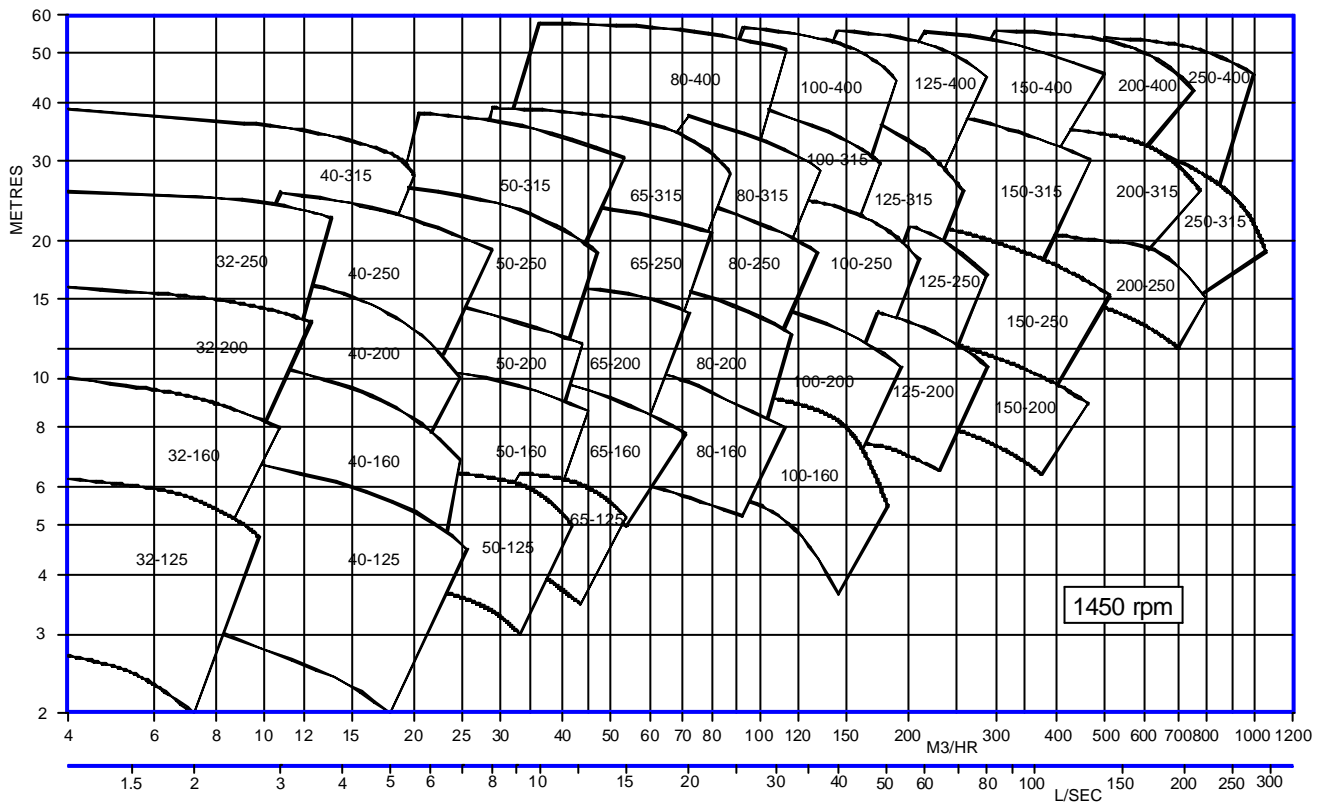
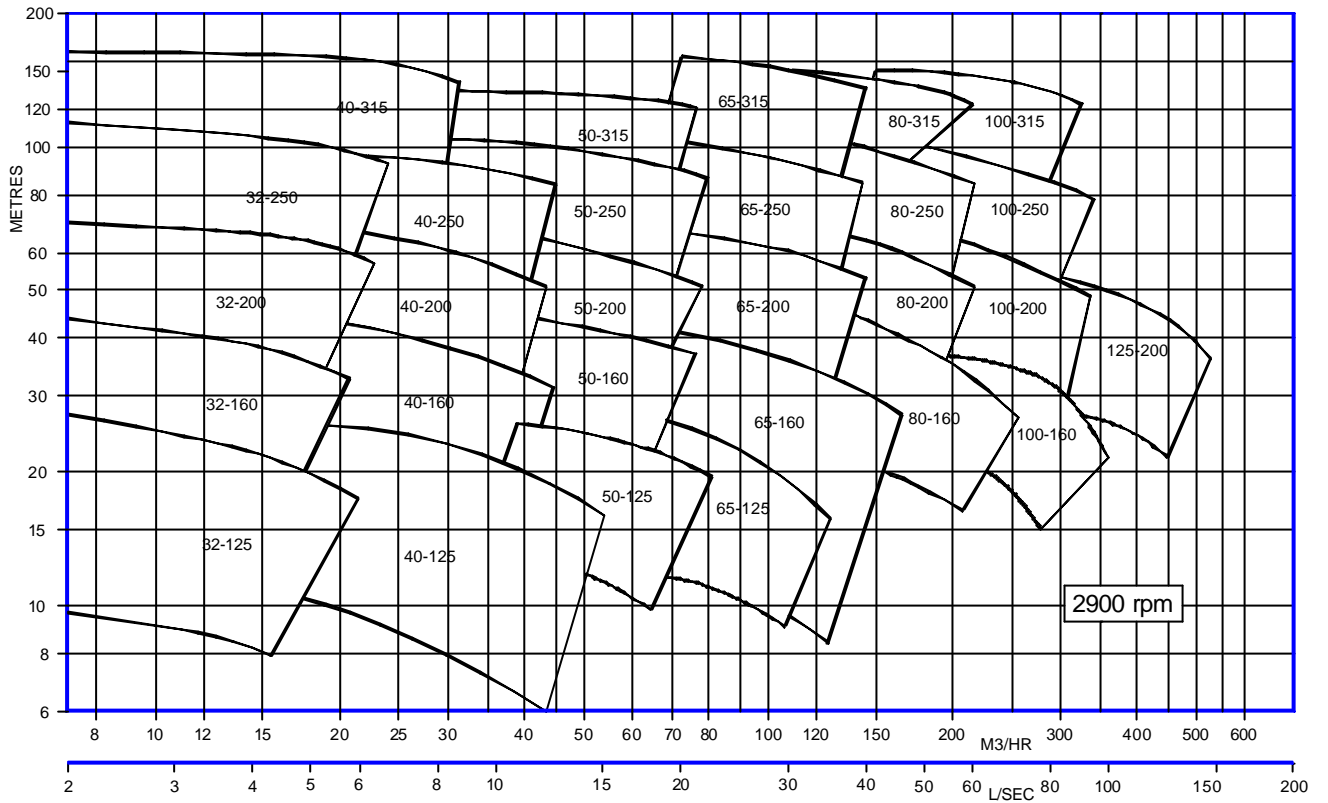

Typical cross section with packed gland

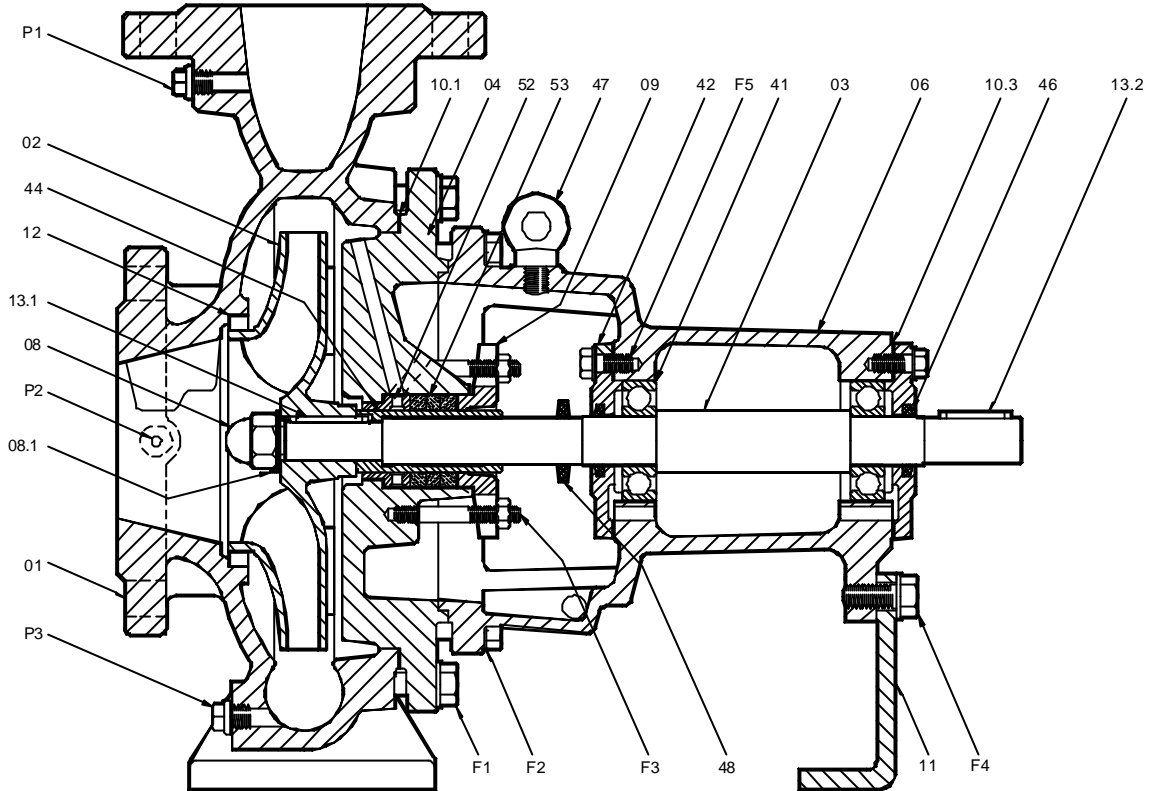

Ref	Item	Standard	Alternative materials
01	Volute casing	Cast iron	Ductile iron, bronze, 316 stainless steel
02	Impeller	Cast iron	Bronze, 316 stainless steel
03	Shaft	420 SS	316 stainless steel, Duplex stainless steel
04	Backcover	Cast iron	Ductile iron, bronze, 316 stainless steel
06	Bearing housing	Cast iron	
08	Impeller nut	Steel	Bronze, 316 stainless steel
08.1	Impeller nut washer	Steel	Bronze, 316 stainless steel
09	Gland	Cast iron	316 stainless steel
10.1	Casing gasket	Gasket paper	Specialist gasket materials
10.3	End cover gasket	Gasket paper	
11	Support foot	Steel	
12	Wear ring	Cast iron	Cast iron, bronze, 316 stainless steel
13.1	Impeller key	Key steel	316 stainless steel
13.2	Coupling key	Key steel	
41	Ball bearing	Steel	
42	Bearing end cover	Cast iron	
44	Shaft sleeve	420 SS	316 stainless steel, Nitride hardened stainless steel
46	Grease seal	Felt	Nitrile rubber lip seal
47	Lifting eye	Steel	
48	Flinger	Nitrile rubber	
52	Lantern ring	LG4 Bronze	Cast iron, 316 stainless steel
53	Gland packing	Cotton/graphite	PTFE, specialist packing materials
F1	Casing bolts	Steel	316 stainless steel
F2	Housing bolts	Steel	316 stainless steel
F3	Gland studs	Steel	316 stainless steel
F4	Support foot bolt	Steel	
F5	End cover bolts	Steel	
P1	Casing vent plug	Steel	316 stainless steel
P2	Suction gauge plug	Steel	316 stainless steel
P3	Casing drain plug	Steel	316 stainless steel

Typical cross section with mechanical seal

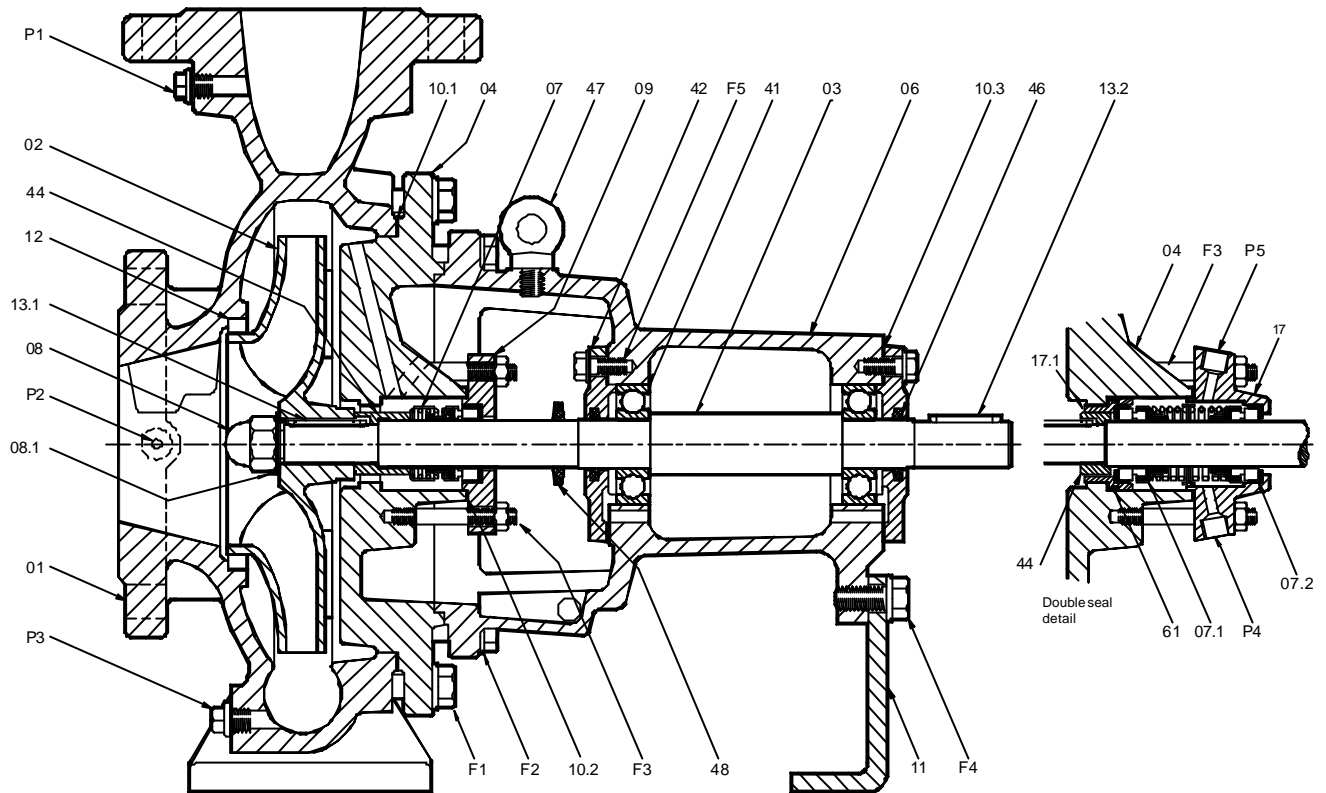

Ref	Item	Standard	Alternative materials
01	Volute casing	Cast iron	Ductile iron, bronze, 316 stainless steel
02	Impeller	Cast iron	Bronze, 316 stainless steel
03	Shaft	420 SS	316 stainless steel, Duplex stainless steel
04	Backcover	Cast iron	Ductile iron, bronze, 316 stainless steel
06	Bearing housing	Cast iron	
07	Mechanical seal	As specified	Any commercially available specification
08	Impeller nut	Steel	Bronze, 316 stainless steel
08.1	Impeller nut washer	Steel	Bronze, 316 stainless steel
09	Glandplate	Cast iron	316 stainless steel
10.1	Casing gasket	Gasket paper	Specialist gasket materials
10.2	Glandplate gasket	Gasket paper	Specialist gasket materials
10.3	End cover gasket	Gasket paper	
11	Support foot	Steel	Key steel, 316 stainless steel
12	Wear ring	Cast iron	Bronze, 316 stainless steel
13.1	Impeller key	Key steel	Key steel, 316 stainless steel
13.2	Coupling key	Key steel	
41	Ball bearing	Steel	
42	Bearing end cover	Cast iron	
44	Spacer sleeve	420 SS	316 stainless steel
46	Grease seal	Felt	Nitrile rubber lip seal
47	Lifting eye	Steel	
48	Flinger	Nitrile rubber	
F1	Casing bolts	Steel	316 stainless steel
F2	Housing bolts	Steel	316 stainless steel
F3	Glandplate studs	Steel	316 stainless steel
F4	Support foot bolt	Steel	
F5	End cover bolts	Steel	
P1	Casing vent plug	Steel	316 stainless steel
P2	Suction gauge plug	Steel	316 stainless steel
P3	Casing drain plug	Steel	316 stainless steel
07.1	Primary Mechanical seal	As specified	Any commercially available specification
07.2	Secondary mechanical seal	As specified	Any commercially available specification
17	Double seal glandplate	316 stainless steel	
17.1	Primary seal carrier	316 stainless steel	
61	O ring	Viton	
P4	Seal flush inlet connection		
P5	Seal flush outlet connection		

Impeller and bearing housing data

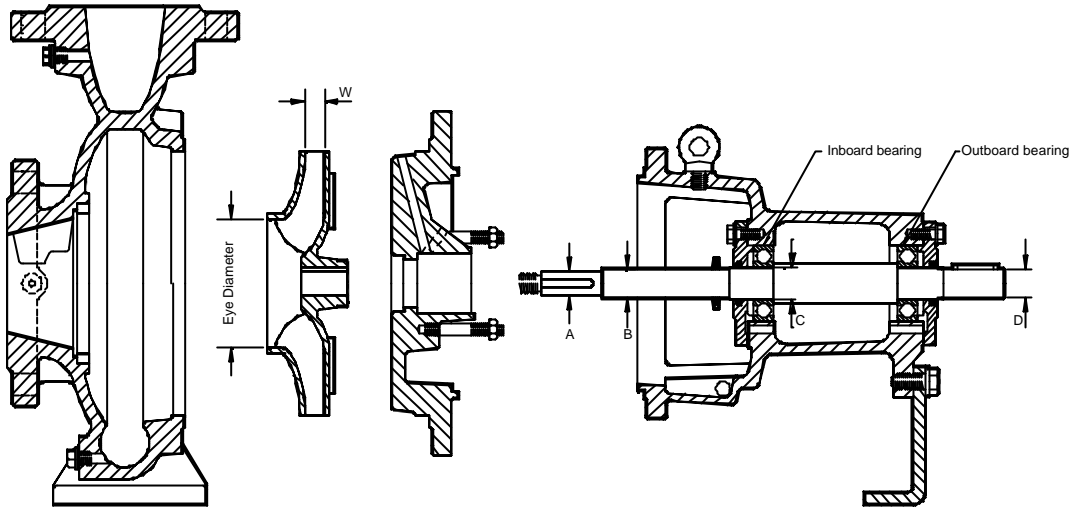

Pump size	Shaft group	Shaft diameter at:				Bearing type		Impeller data				
		Impeller A	Seal B	Bearings C	Coupling D	Inboard	Outboard	No of Vanes	Eye dia mm	Width W	Max solids mm	M of I Kgm ²
32-125	1	20	24	25	24	6305	6305	6	62	6.5	3.3	0.003
32-160	1	20	24	25	24	6305	6305	6	63	7.0	3.5	0.005
32-200	1	20	24	25	24	6305	6305	4	68	6.0	3.0	0.012
32-250	1	20	24	25	24	6305	6305	6	71	6.0	3.0	0.034
40-125	1	20	24	25	24	6305	6305	6	72	10.5	5.3	0.003
40-160	1	20	24	25	24	6305	6305	6	68	6.0	3.0	0.005
40-200	1	20	24	25	24	6305	6305	6	67	8.0	4.0	0.015
40-250	1	20	24	25	24	6305	6305	6	84	5.5	2.8	0.038
40-315	2	28	32	35	32	6307	6307	6	77	7.0	3.5	0.087
50-125	1	20	24	25	24	6305	6305	6	89	16.5	8.3	0.004
50-160	1	20	24	25	24	6305	6305	6	85	13.5	6.8	0.006
50-200	1	20	24	25	24	6305	6305	6	87	10.0	5.0	0.015
50-250	1	20	24	25	24	6305	6305	7	95	8.0	4.0	0.040
50-315	2	28	32	35	32	6307	6307	6	101	8.0	4.0	0.091
65-125	1	20	24	25	24	6305	6305	7	101	23.0	11.5	0.005
65-160	1	20	24	25	24	6305	6305	6	99	18.5	9.3	0.008
65-200	1	20	24	25	24	6305	6305	6	107	16.0	8.0	0.015
65-250	2	28	32	35	32	6307	6307	6	108	13.5	6.8	0.042
65-315	2	28	32	35	32	6307	6307	7	114	11.5	5.8	0.102
80-160	1	20	24	25	24	6305	6305	7	117	25.0	12.5	0.010
80-200	2	28	32	35	32	6307	6307	7	121	21.5	10.8	0.019
80-250	2	28	32	35	32	6307	6307	7	120	15.0	7.5	0.040
80-315	2	28	32	35	32	6307	6307	7	120	13.0	6.5	0.089
80-400	3	38	44	45	42	6309	6309	6	128	10.0	5.0	0.325
100-160	2	28	32	35	32	6307	6307	7	148	32.0	16.0	0.020
100-200	2	28	32	35	32	6307	6307	7	142	26.5	13.3	0.024
100-250	2	28	32	35	32	6307	6307	7	143	30.5	15.3	0.055
100-315	2	28	32	35	32	6307	6307	7	144	19.5	9.8	0.128
100-400	3	38	44	45	42	6309	6309	7	148	14.5	7.3	0.295
125-200	2	28	32	35	32	6307	6307	7	169	36.0	18.0	0.055
125-250	2	28	32	35	32	6307	6307	6	168	31.5	15.8	0.063
125-315	3	38	44	45	42	6309	6309	6	167	24.5	12.3	0.136
125-400	3	38	44	45	42	6309	6309	6	167	22.0	11.0	0.310
150-200	2a	28	32	35	32	6307	6307	6	169	56.0	28.0	0.090
150-250	3	38	44	45	42	6309	6309	7	185	40.0	20.0	0.100
150-315	3	38	44	45	42	6309	6309	6	184	32.0	16.0	0.150
150-400	3	38	44	45	42	6309	6309	7	188	26.5	13.3	0.330
200-250	3	38	44	45	42	6309	6309	6	230	62	31	0.202
200-315	4	45	53	55	48	6311	6311	6	232.5	50	25	0.236
200-400	4	45	53	55	48	6311	6311	7	222	37.5	19	0.654
250-315	4	45	53	55	48	6311	6311	6	242	72	36	0.939
250-400	4	45	53	55	48	6311	6311	6	235	52	26	0.725

Fabricated bedplate selection and size

Standard bedplates are fabricated from rolled steel sections, and are intended to be grouted into position on a suitable concrete plinth. The tables below indicate which bedplate size is required for a particular pump and motor

combination, and give the general dimensions. Alternative skid-type bedplates and drain-rim bedplates are also available, either following the general dimensions below, or fabricated to customer's specification.

Pump model	D80/90	D100/12	D132	D160	D180M	D180L	D200	D225	D250S
32-125	2a								
32-160	2a	3a							
32-200	2a	3a	4a						
32-250	4b	4b	4b	5b	5b	5b			
40-125	2a	3a							
40-160	2a	3a	4a						
40-200	3a	3a	4a	5a	5a	5a			
40-250	4b	4b	4b	5b	5b	5b			
40-315		5b	5b	6b	6b	6b	7b	7b	
50-125	2a	3a	3a						
50-160	3a	3a	4a	5a	5a	5a			
50-200	3a	3a	4a	5a	5a	5a			
50-250		4b	4b	5b	5b	5b			
50-315		5b	5b	6b	6b	6b	7b	7b	8b
65-125	3b	3b	4b	5b	5b	5b			
65-160	3b	3b	4b	5b	5b	5b			
65-200	4b	4b	4b	5b	5b	5b	6b		
65-250		6c	6c	6c	6c	6c	6c	7c	8c
65-315		6c	6c	6c	6c	6c	6c	7c	8c
80-160	4b	4b	4b	5b	5b	5b	6b		
80-200	5b	5b	5b	6b	6b	6b	7b	7b	

Pump model	D100/12	D132	D160	D180M	D180L	D200	D225	D250S	D250M	D280S/M	D315S/M
80-250	6c	6c	6c	6c	6c	7c	7c	8c	9c		
80-315		6c	6c	6c	6c	7c	7c	8c	9c	9c	
80-400		7c	7c	7c	7c	7c	7c				
100-160	5c	5c	6c	6c	6c	7c	7c				
100-200	5c	5c	6c	6c	6c	7c	7c	8c	9c		
100-250		6c	6c	6c	6c	7c	7c	8c			
100-315		6c	6c	6c	7c	7c	7c	8c	9c	9c	11e
100-400			8d	8d	8d	8d	8d				
125-200		6c	6c	6c	6c	7c	7c	8c	9c	9c	
125-250		6c	6c	6c	7c						
125-315			8d	8d	8d	8d	8d				
125-400			8d	8d	8d	8d	8d	8d			
150-200			7d	7d	7d	7d					
150-250			7d	7d	7d	8d	8d				
150-315			9d	9d	9d	9d	9d	9d			
150-400						9d	9d	9d	9d	9d	
200-250							9d	9d	9d		
200-315								10e	10e	10e	
200-400								10e	10e	10e	11e
250-315								10e	10e	10e	
250-400									10e	11e	

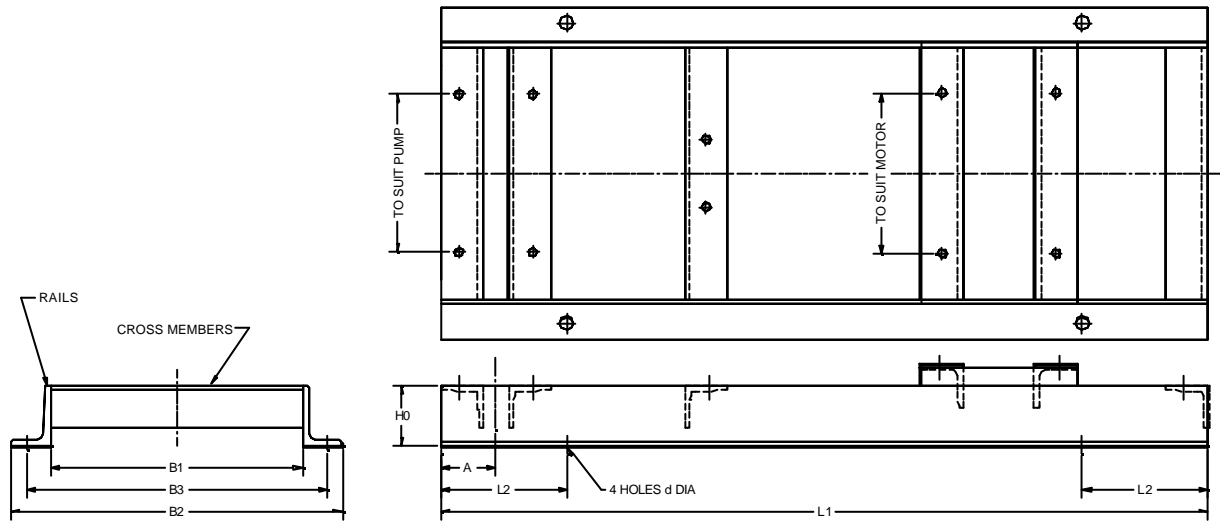

Ref	H0	A	L1	L2	B1	B2	B3	d	Rails	Cross members	kg
2a	75	60	800	130	260	360	320	18	75x50x8 angle	50x50x6 angle	25
3a	75	60	900	150	290	390	350	18	75x50x8 angle	50x50x6 angle	27
3b	75	75	900	150	290	390	350	18	75x50x8 angle	70x70x8 angle	36
4a	75	60	1000	170	350	450	400	22	75x50x8 angle	50x50x6 angle	32
4b	75	75	1000	170	350	450	400	22	75x50x8 angle	70x70x8 angle	42
5a	100	60	1120	190	360	490	440	22	100x65x10 angle	50x50x6 angle	49
5b	100	75	1120	190	360	490	440	22	100x65x10 angle	70x70x8 angle	60
6b	100	75	1250	205	410	540	490	22	100x65x10 angle	70x70x8 angle	67
6c	100	90	1250	205	410	540	490	22	100x65x10 angle	80x80x10 angle	78
7b	100	75	1400	230	480	610	550	25	100x65x10 angle	70x70x8 angle	76
7c	100	90	1400	230	480	610	550	25	100x65x10 angle	80x80x10 angle	89
7d	100	110	1400	230	480	610	550	25	100x65x10 angle	100x100x10 angle	101
8c	152	90	1600	270	508	660	600	25	152x76 channel	80x80x10 angle	122
8d	152	110	1600	270	508	660	600	25	152x76 channel	100x100x10 angle	134
9c	152	90	1800	300	578	730	670	25	152x76 channel	80x80x10 angle	137
9d	152	110	1800	300	578	730	670	25	152x76 channel	100x100x10 angle	152
10e	152	140	1900	315	698	850	780	28	152x76 channel	100x100x10 angle	156
11e	203	140	2000	330	772	950	870	28	203x89 channel	100x100x10 angle	207

Folded steel bedplate selection and size

Folded steel bedplates are fabricated from mild steel sheet, with welded ends which incorporate lifting eyes. Folded steel bedplates may be secured to concrete foundations without the need for grouting.

Folded steel bedplates are only available for motors up to framesize D180 (22 kW motor output). For larger pump and motor sizes, use the fabricated steel style of bedplate on the previous page.

Pump model	D80 D90	D100 D112	D132	D160	D180M	D180L
32-125	2a					
32-160	2a	3a				
32-200	2a	3a	4a			
32-250	4b	4b	4b	5b	5b	5b
40-125	2a	3a				
40-160	2a	3a	4a			
40-200	3a	3a	4a	5a	5a	5a
40-250	4b	4b	4b	5b	5b	5b
40-315		5b	5b	6b	6b	6b
50-125	2a	3a	3a			
50-160	3a	3a	4a	5a	5a	5a
50-200	3a	3a	4a	5a	5a	5a
50-250		4b	4b	5b	5b	5b
50-315		5b	5b	6b	6b	6b

Pump model	D80 D90	D100 D112	D132	D160	D180M	D180L
65-125	3b	3b	4b	5b	5b	5b
65-160	3b	3b	4b	5b	5b	5b
65-200	4b	4b	4b	5b	5b	5b
65-250		6c	6c	6c	6c	6c
65-315		6c	6c	6c	6c	6c
80-160	4b	4b	4b	5b	5b	5b
80-200	5b	5b	5b	6b	6b	6b
80-250		6c	6c	6c	6c	6c
80-315			6c	6c	6c	6c
100-160		5c	5c	6c	6c	6c
100-200		5c	5c	6c	6c	6c
100-250			6c	6c	6c	6c
100-315			6c	6c	6c	6c

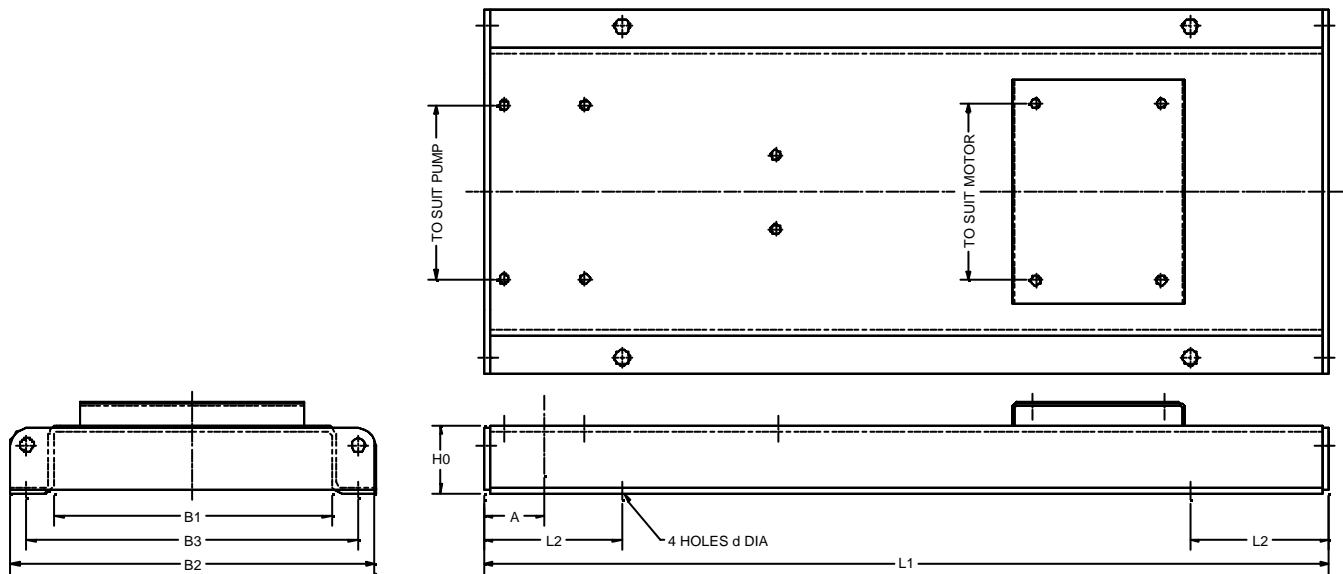

Bedplate ref	H0	A	L1	L2	B1	B2	B3	d	Bedplate steel	End sections	Mass kg
2a	75	60	800	130	260	360	320	18	6 mm steel plate	10 mm steel plate	23
3a	75	60	900	150	290	390	350	18	6 mm steel plate	10 mm steel plate	27
3b	75	75	900	150	290	390	350	18	6 mm steel plate	10 mm steel plate	27
4a	75	60	1000	170	350	450	400	22	6 mm steel plate	10 mm steel plate	33
4b	75	75	1000	170	350	450	400	22	6 mm steel plate	10 mm steel plate	33
5a	100	60	1120	190	360	490	440	22	6 mm steel plate	10 mm steel plate	44
5b	100	75	1120	190	360	490	440	22	6 mm steel plate	10 mm steel plate	44
6b	100	75	1250	205	410	540	490	22	6 mm steel plate	10 mm steel plate	52
6c	100	90	1250	205	410	540	490	22	6 mm steel plate	10 mm steel plate	52

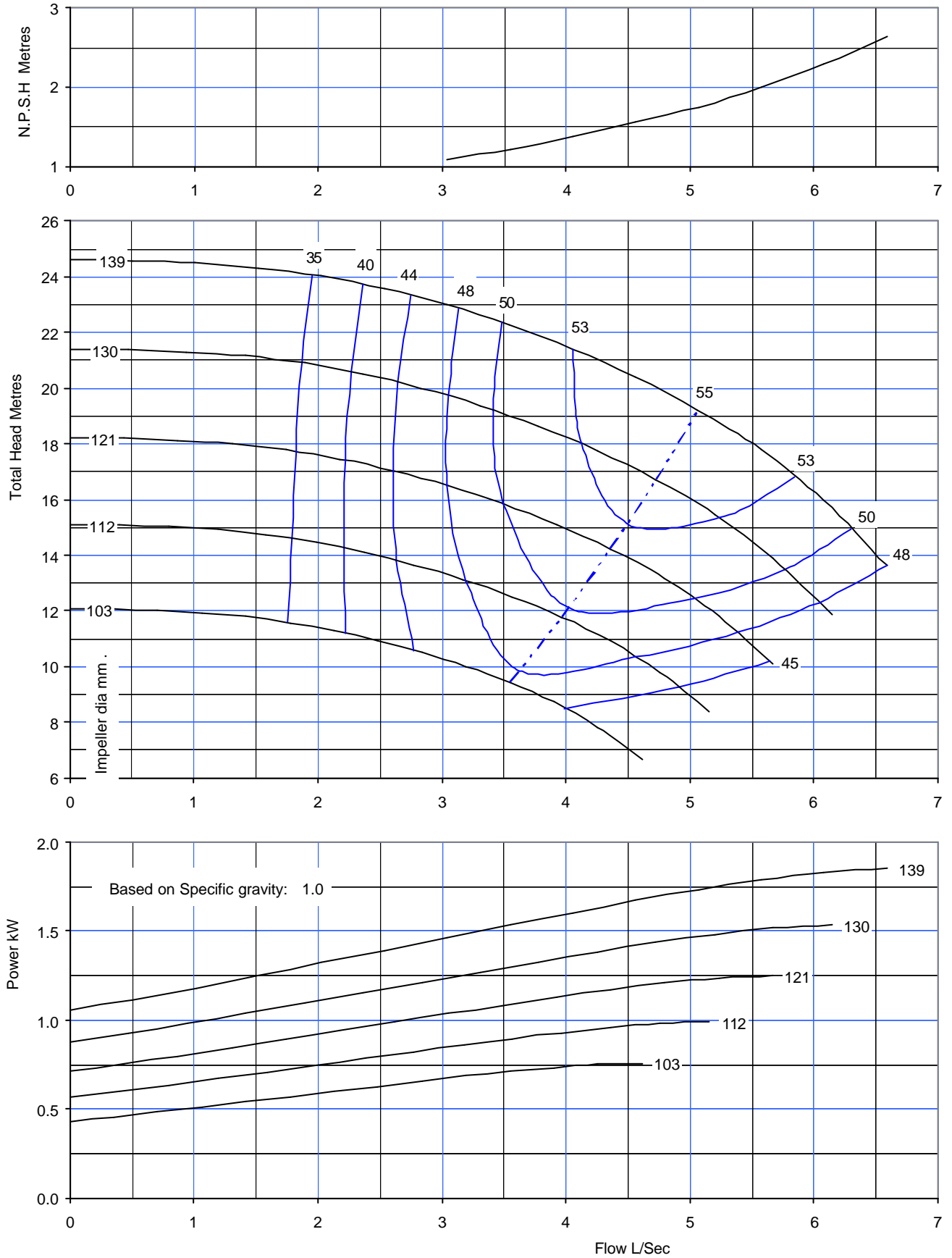

SUCTION DIA 50	DISCHARGE DIA 32	MAX PRESSURE 12 bar	PUMP MODEL TD 32-125	SPEED 2860
--------------------------	----------------------------	-------------------------------	--------------------------------	----------------------

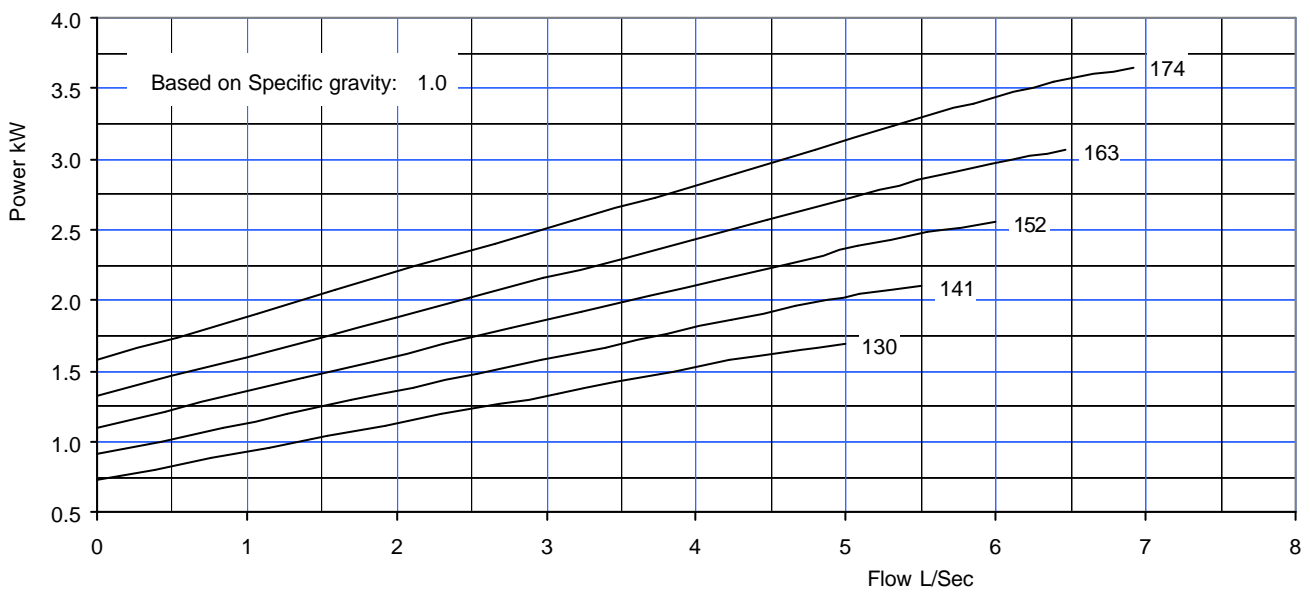
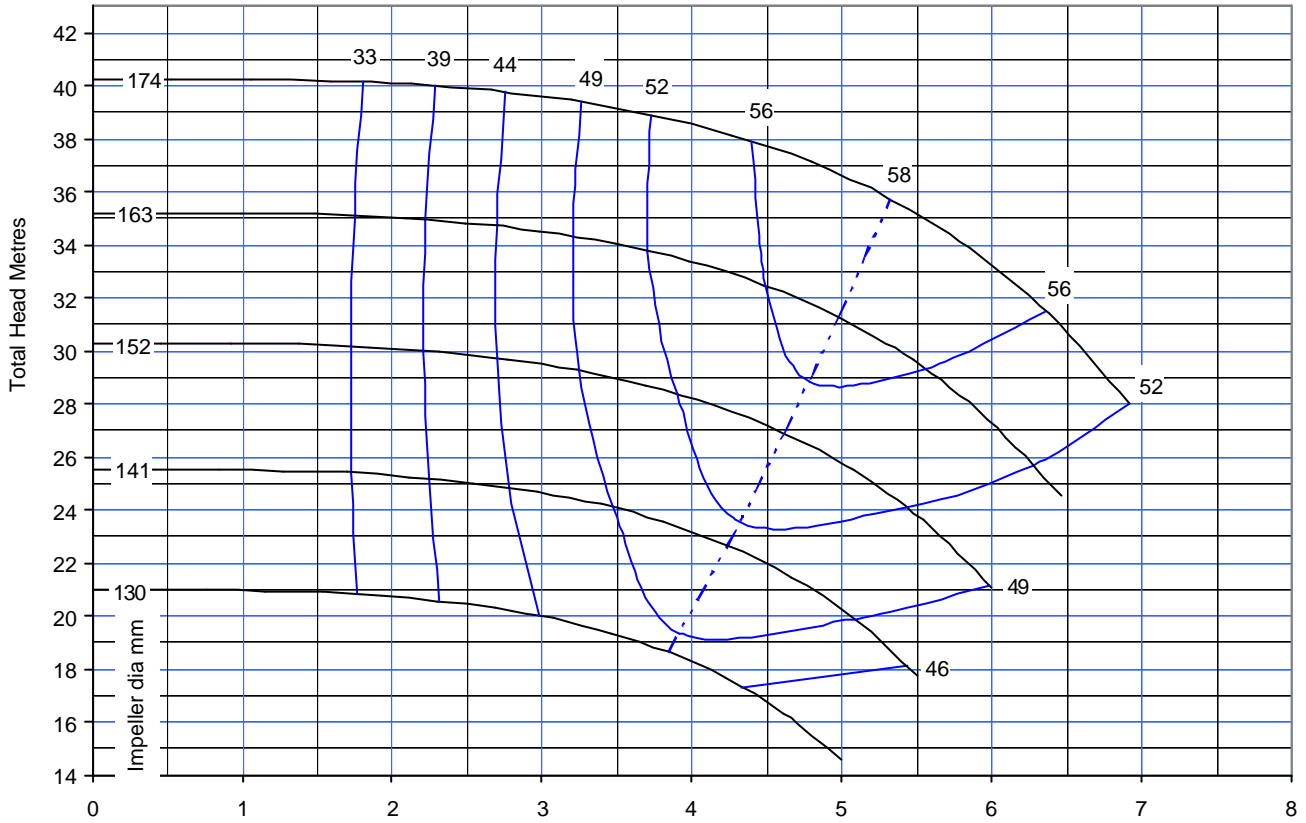
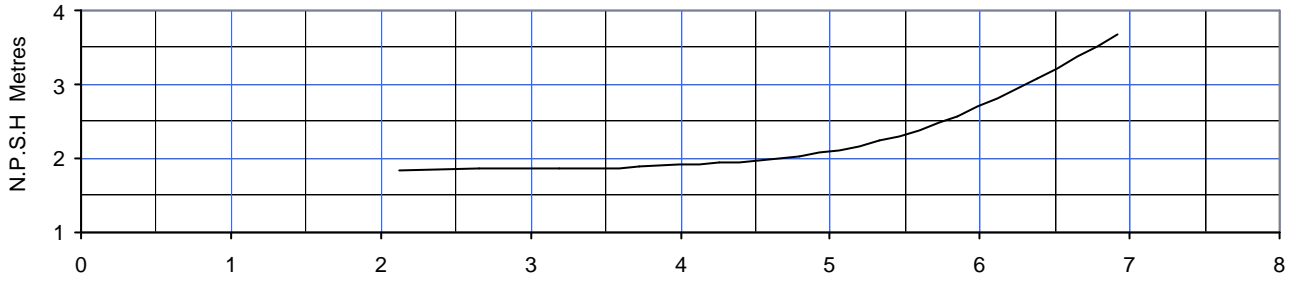

SUCTION DIA 50	DISCHARGE DIA 32	MAX PRESSURE 12 bar	PUMP MODEL TD 32-160	SPEED 2880
--------------------------	----------------------------	-------------------------------	--------------------------------	----------------------

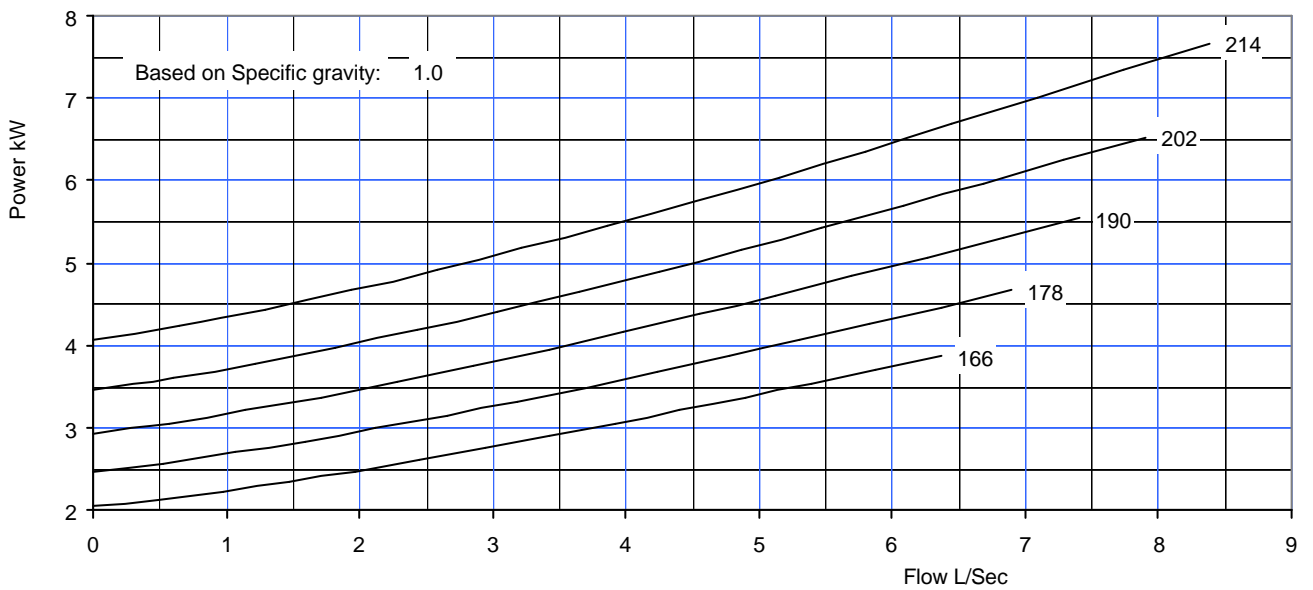
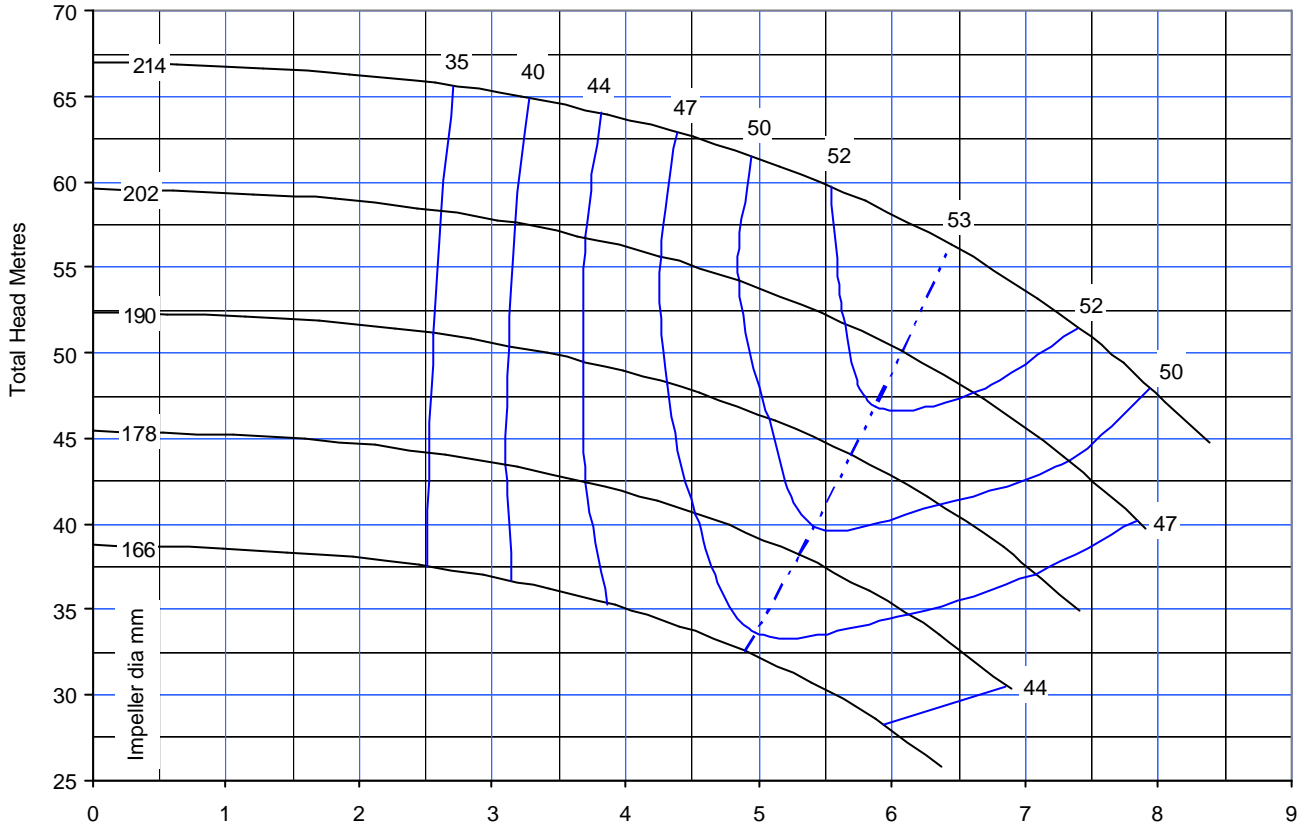
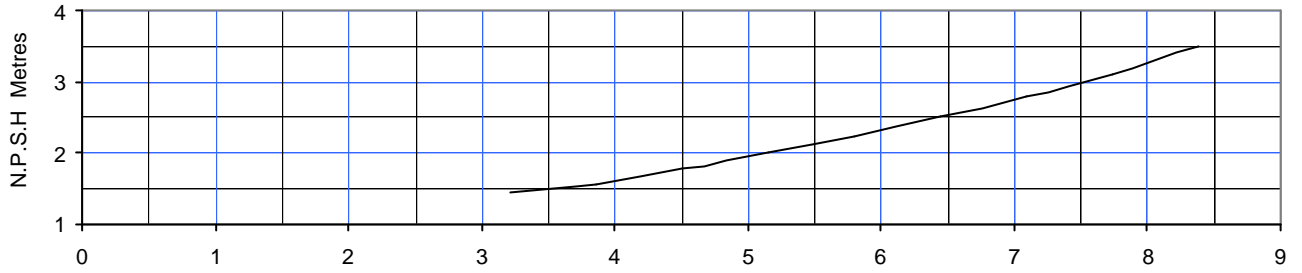

SUCTION DIA 50	DISCHARGE DIA 32	MAX PRESSURE 12 bar	PUMP MODEL TD 32-200	SPEED 2900
--------------------------	----------------------------	-------------------------------	--------------------------------	----------------------

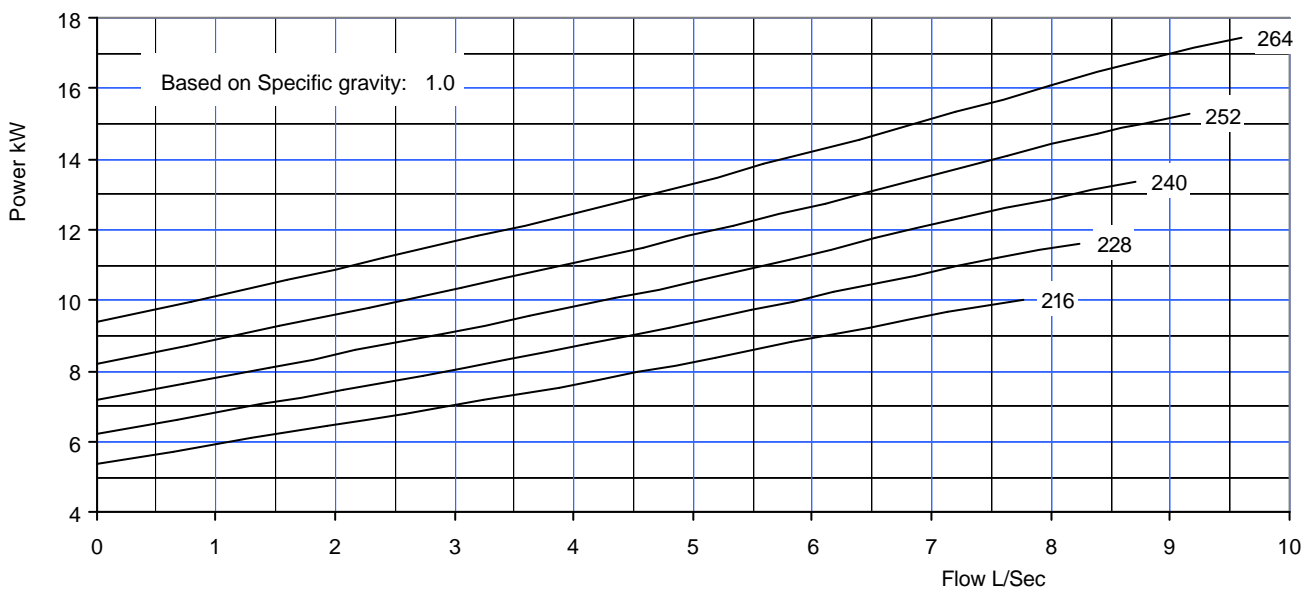
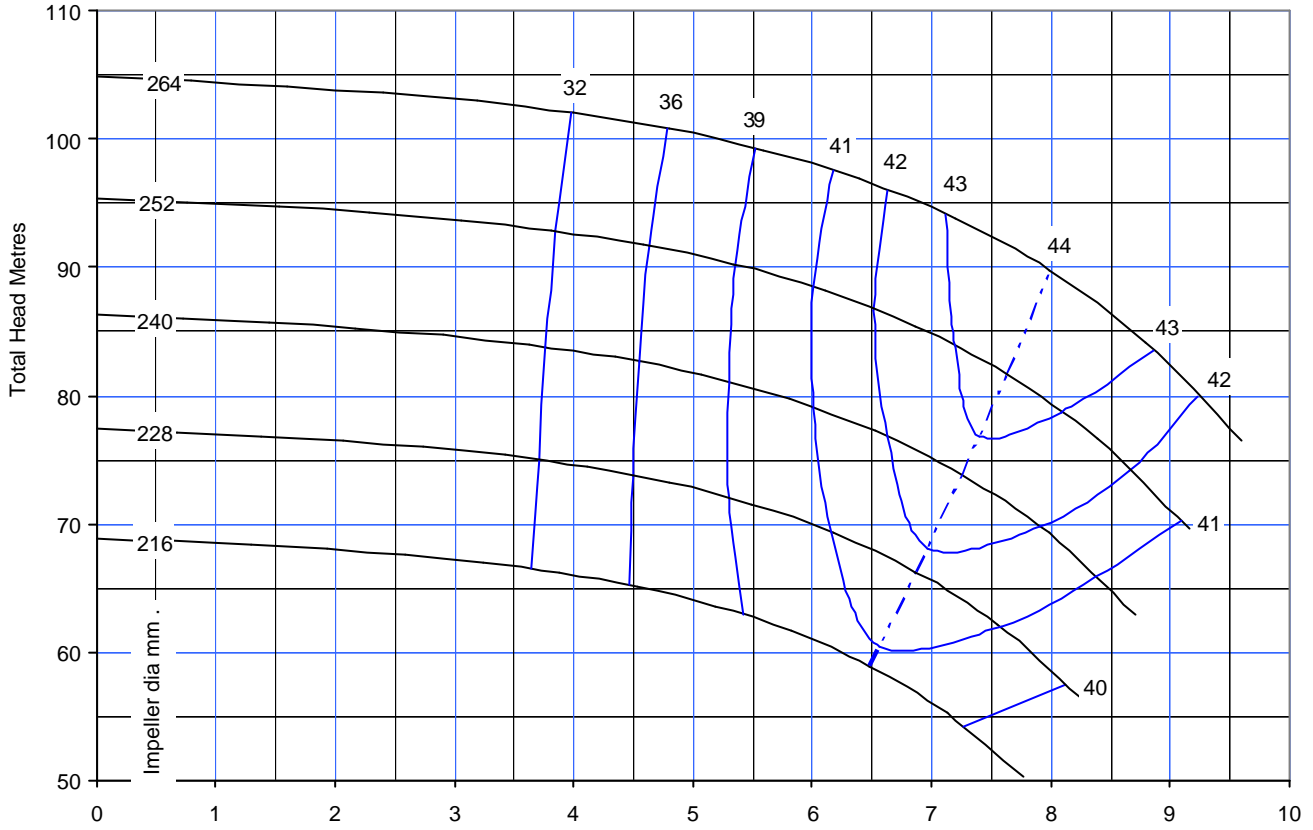
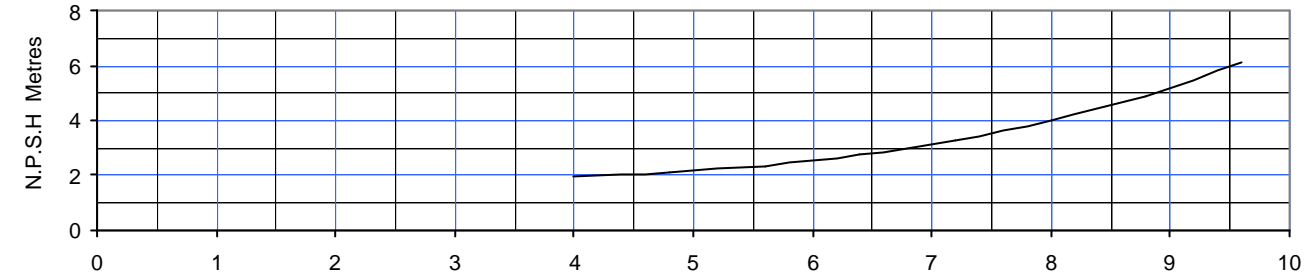

SUCTION DIA 50	DISCHARGE DIA 32	MAX PRESSURE 12 bar	PUMP MODEL TD 32-250	SPEED 2940
--------------------------	----------------------------	-------------------------------	--------------------------------	----------------------

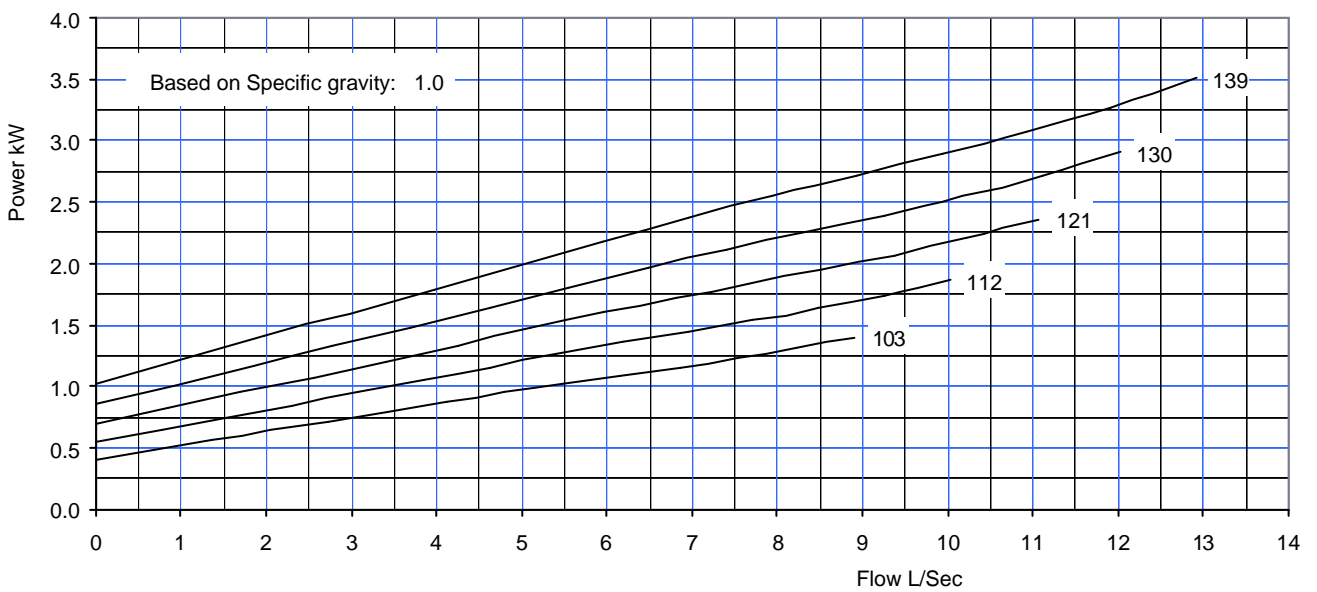
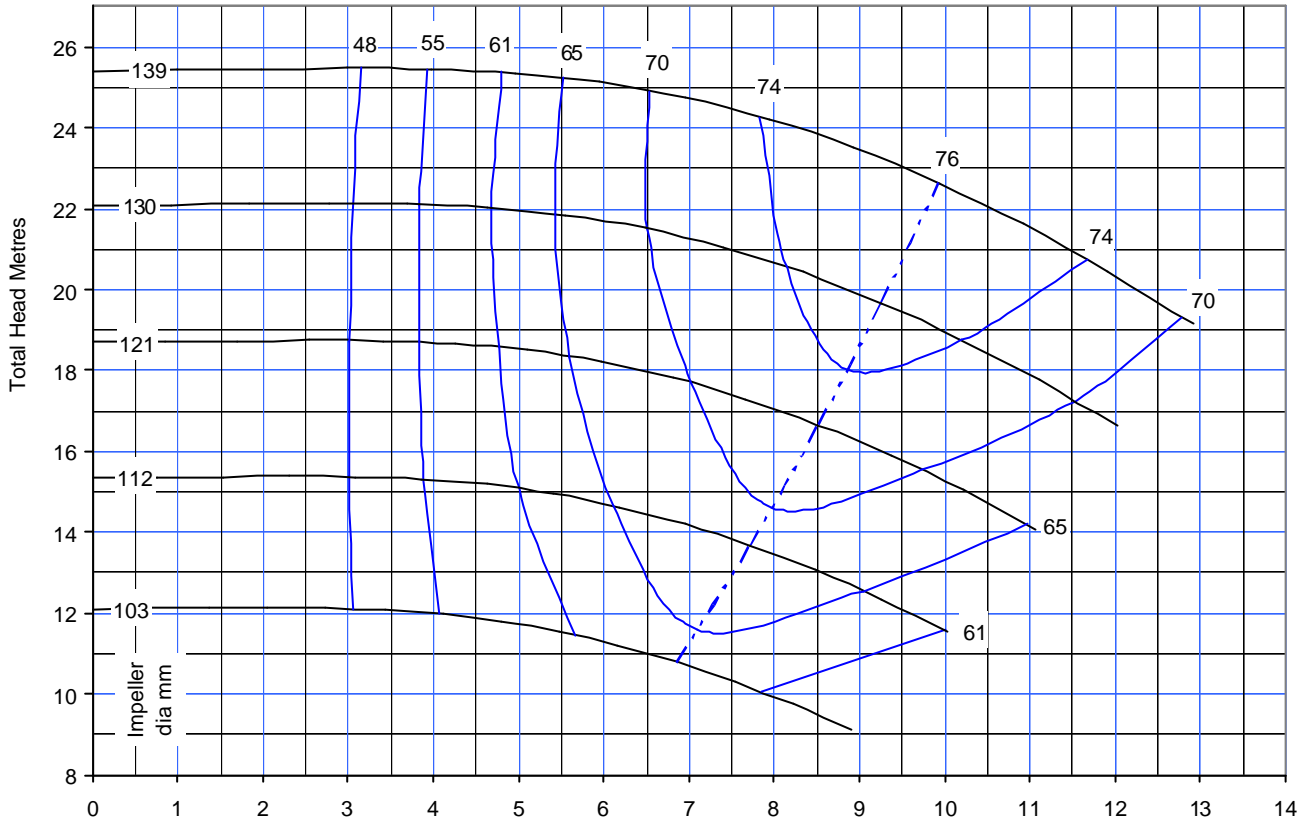
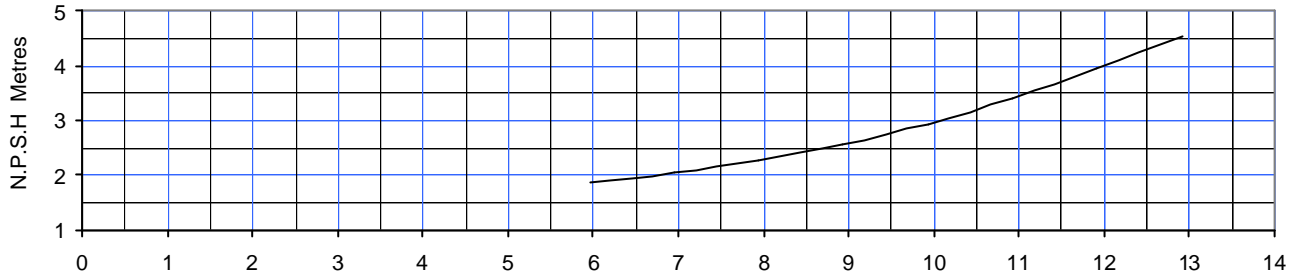

SUCTION DIA 65	DISCHARGE DIA 40	MAX PRESSURE 12 bar	PUMP MODEL TD 40-125	SPEED 2880
--------------------------	----------------------------	-------------------------------	--------------------------------	----------------------

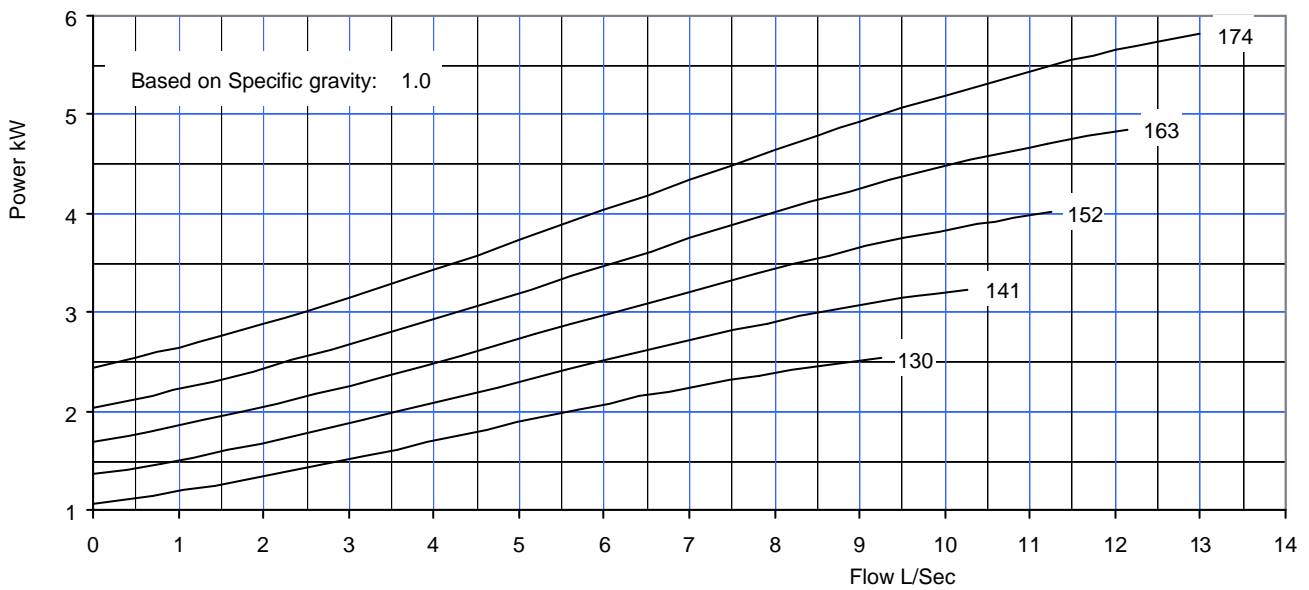
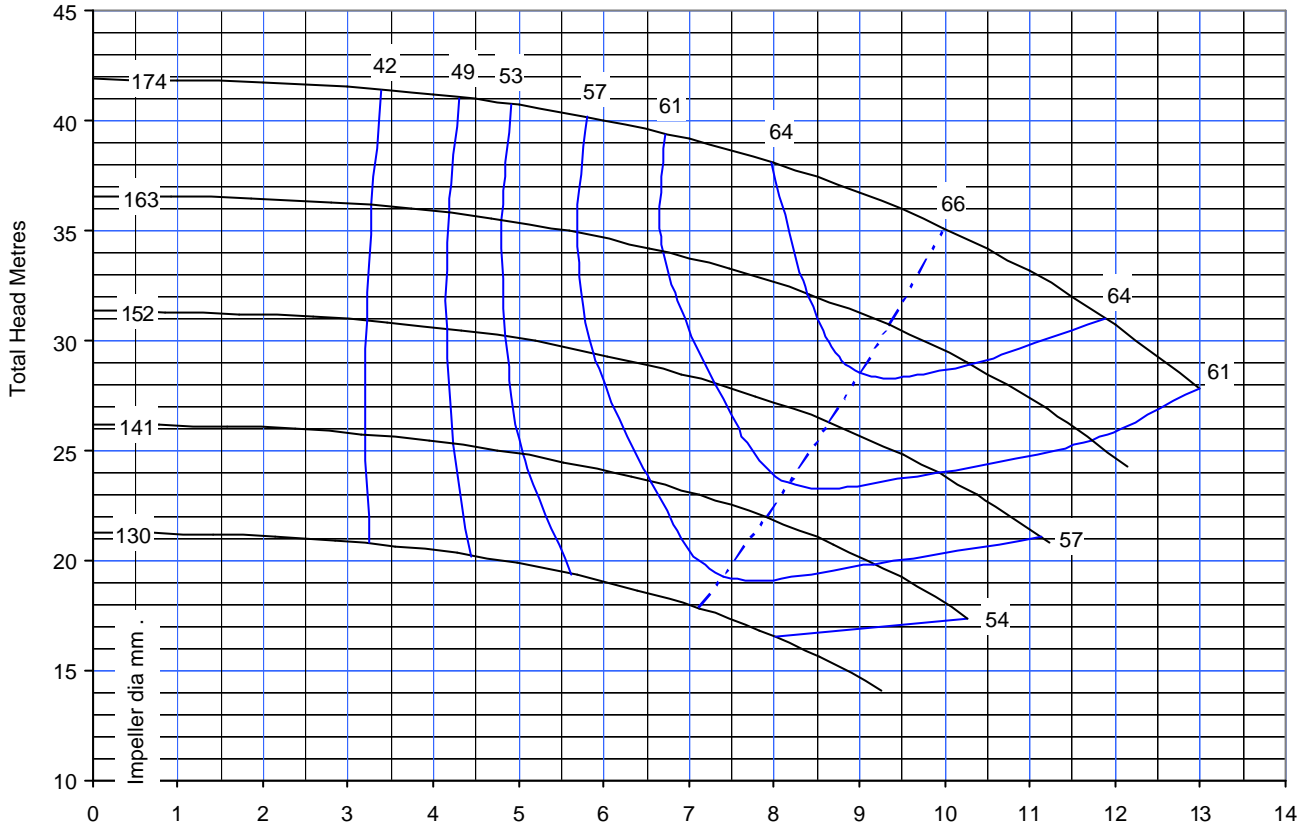
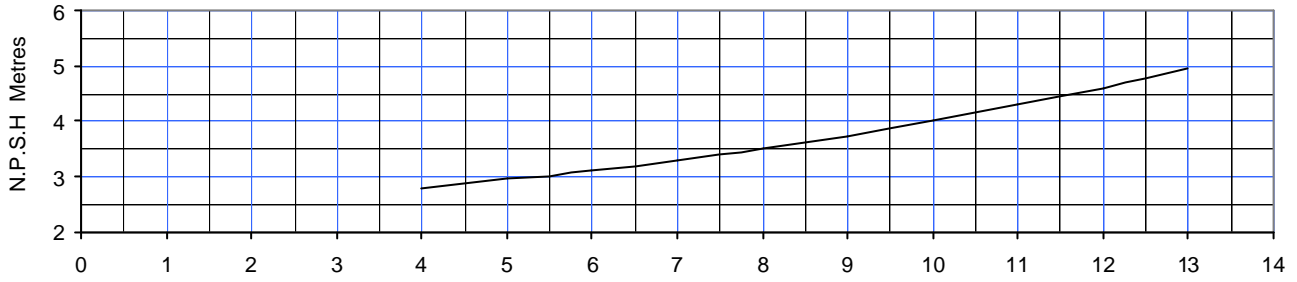

SUCTION DIA 65	DISCHARGE DIA 40	MAX PRESSURE 12 bar	PUMP MODEL TD 40-160	SPEED 2900
--------------------------	----------------------------	-------------------------------	--------------------------------	----------------------

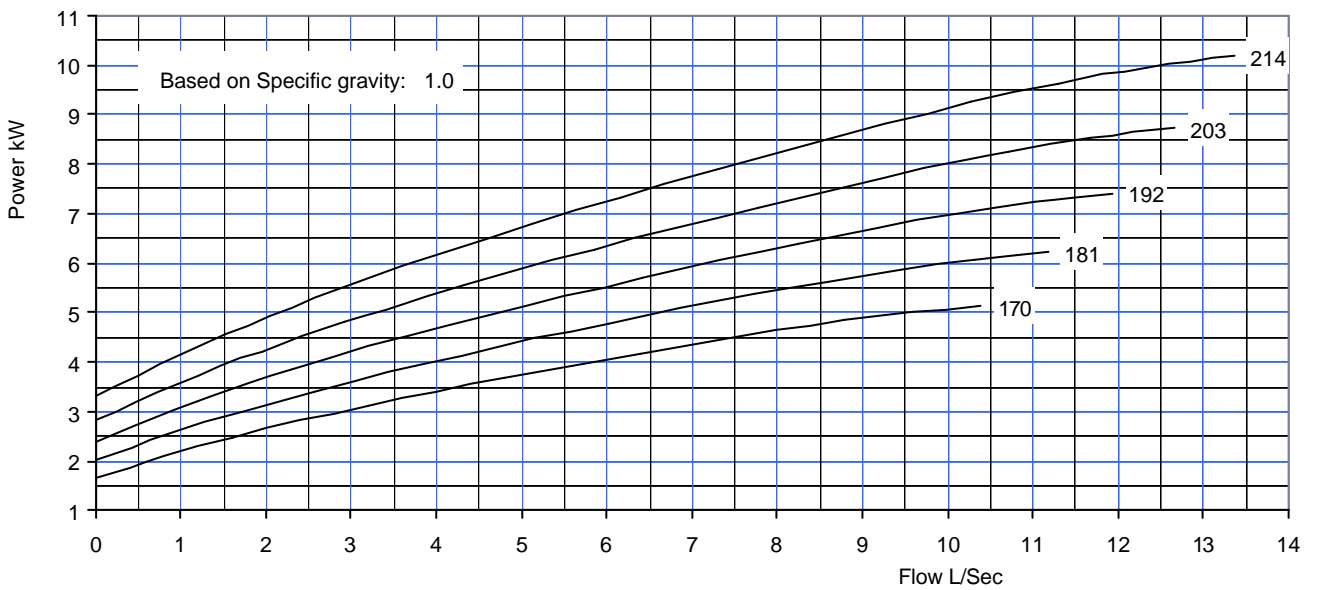
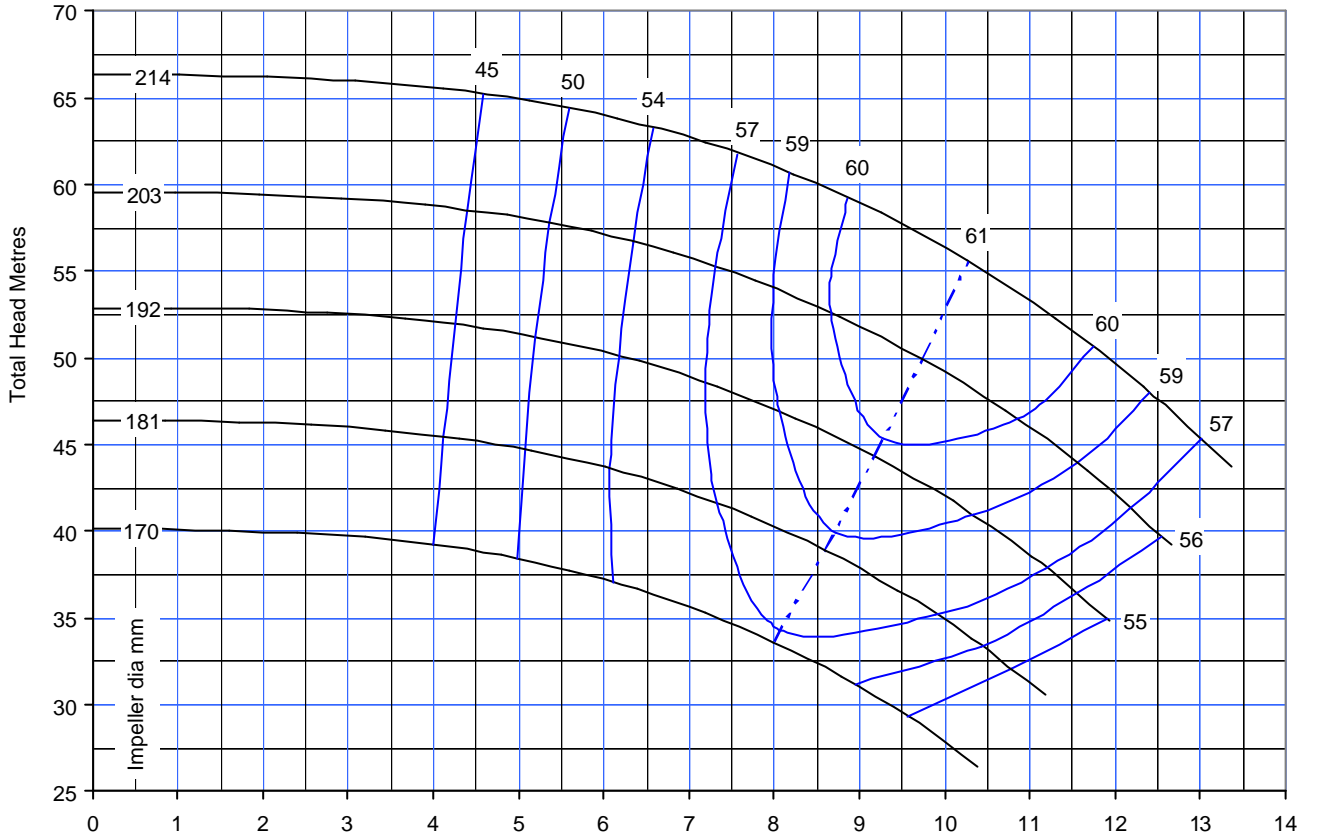
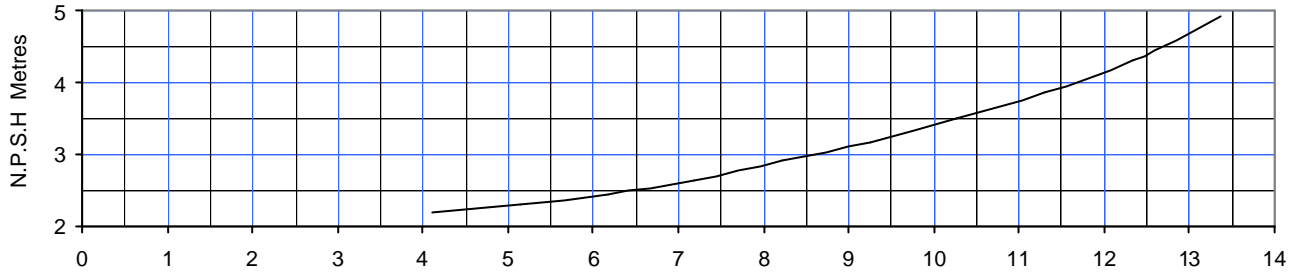

SUCTION DIA 65	DISCHARGE DIA 40	MAX PRESSURE 12 bar	PUMP MODEL TD 40-200	SPEED 2900
--------------------------	----------------------------	-------------------------------	--------------------------------	----------------------

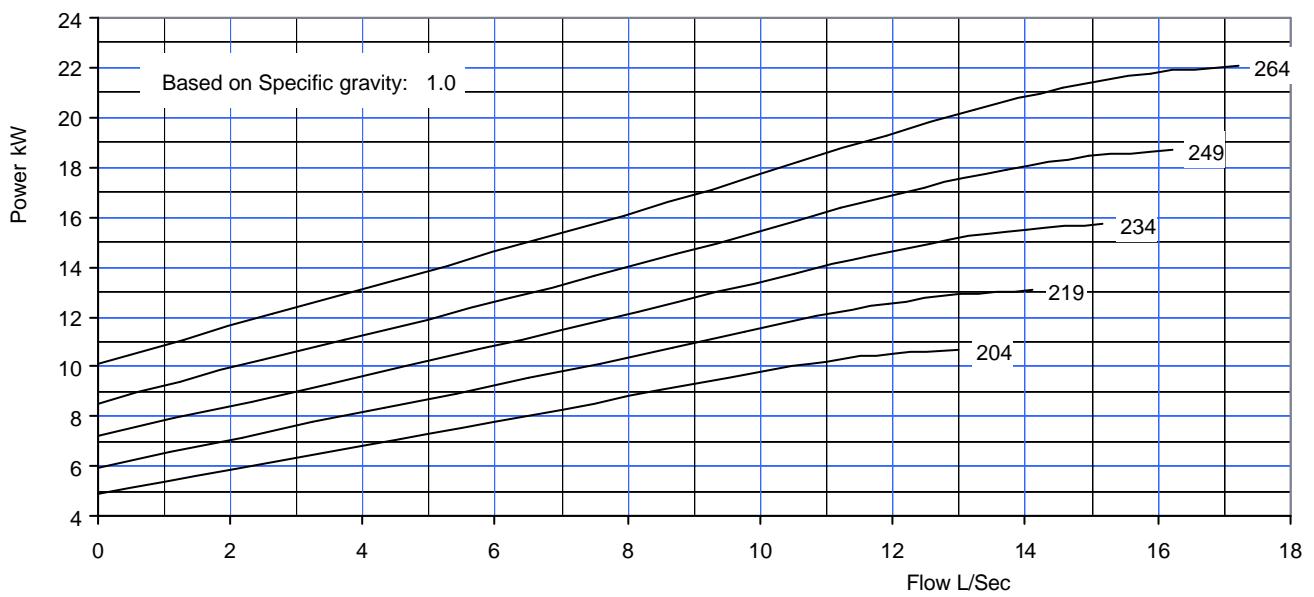
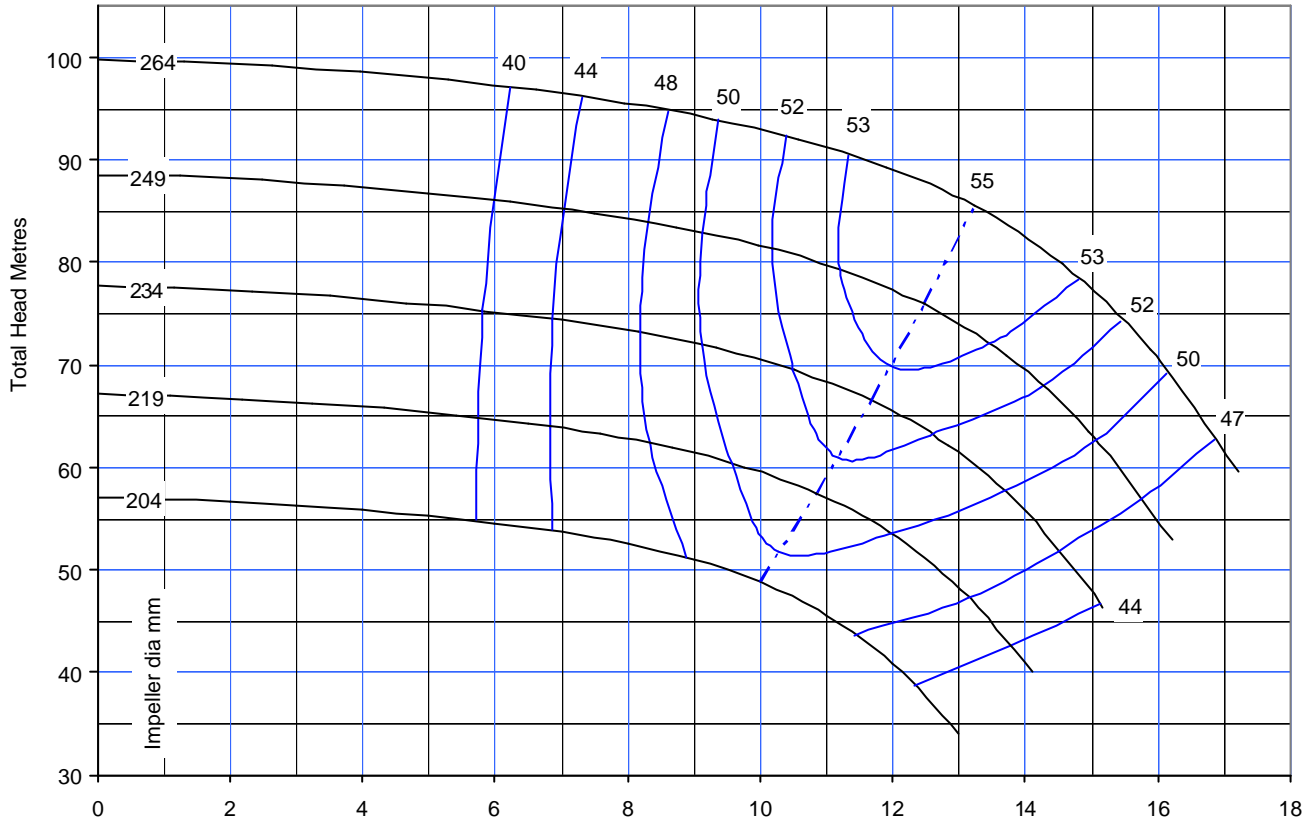
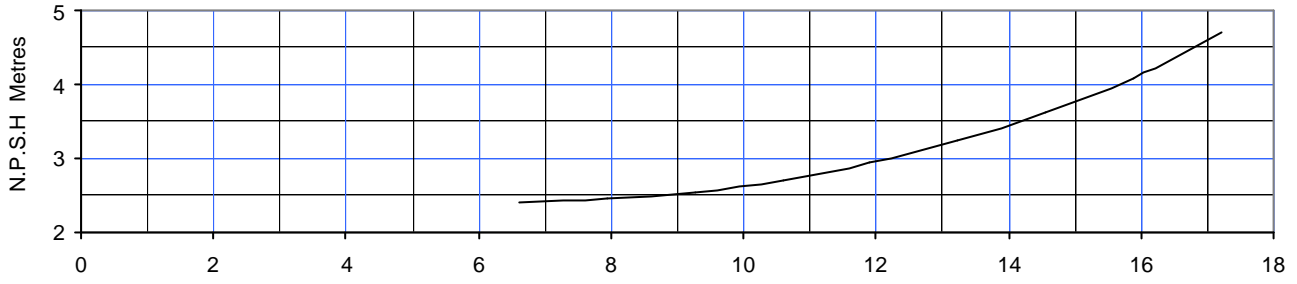

SUCTION DIA 65	DISCHARGE DIA 40	MAX PRESSURE 12 bar	PUMP MODEL TD 40-250	SPEED 2940
--------------------------	----------------------------	-------------------------------	--------------------------------	----------------------

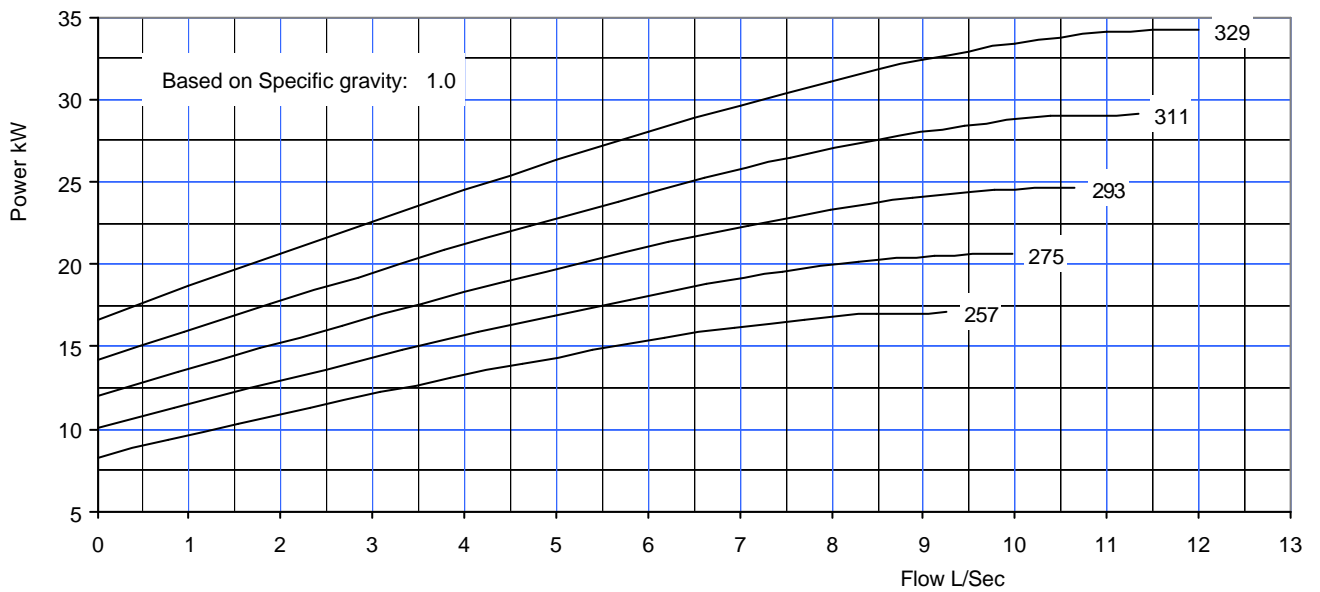
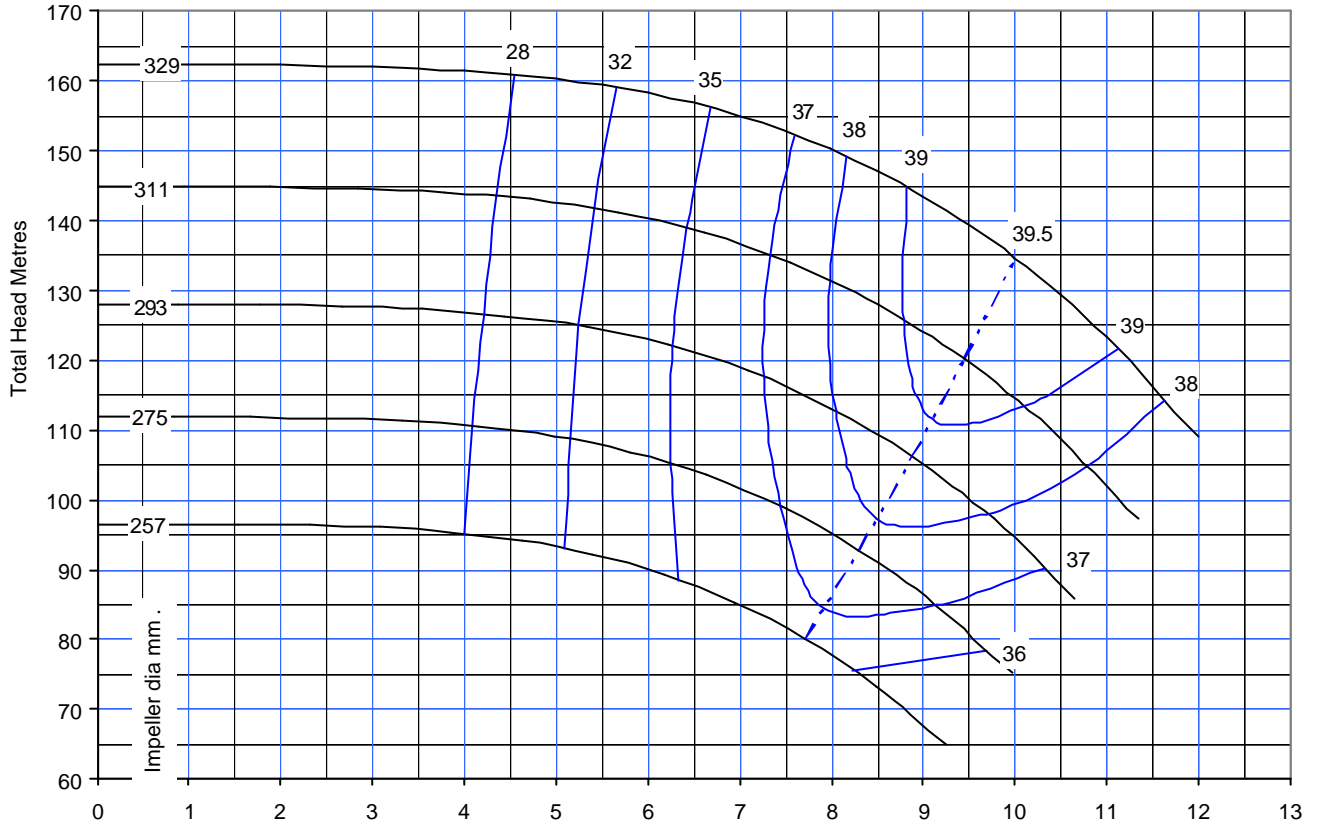
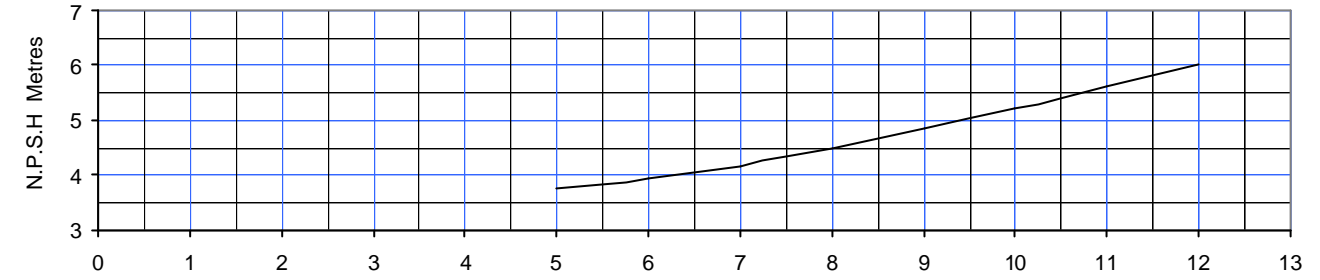

SUCTION DIA 65	DISCHARGE DIA 40	MAX PRESSURE 16 bar	PUMP MODEL TD 40-315	SPEED 2940
--------------------------	----------------------------	-------------------------------	--------------------------------	----------------------

APEX PUMPS MORLEY ROAD STAPLE HILL BRISTOL BS16 4QT TEL:0117 907 7555 FAX: 0117 907 7556

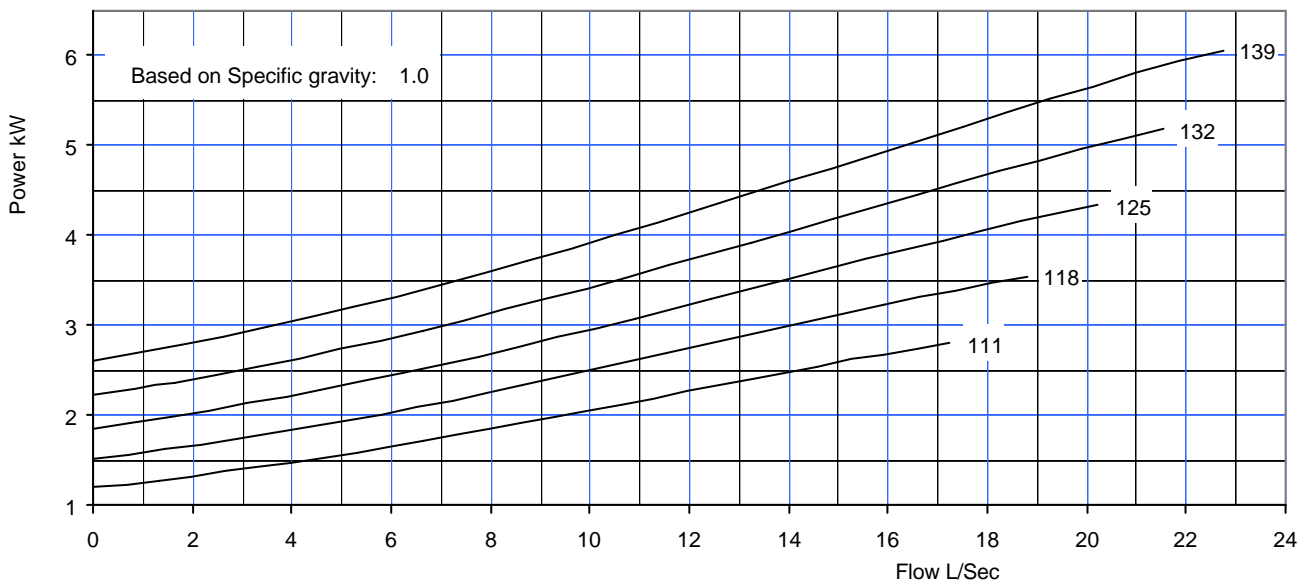
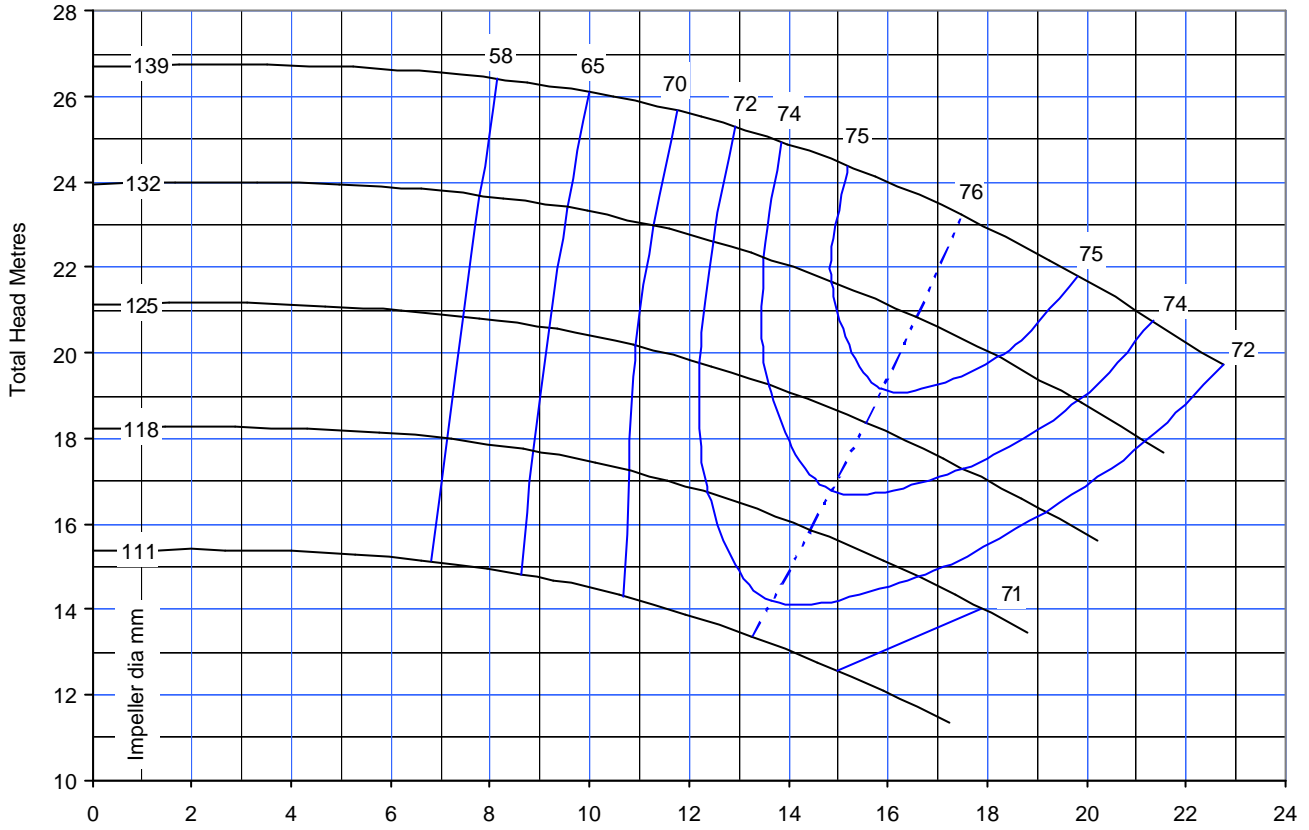
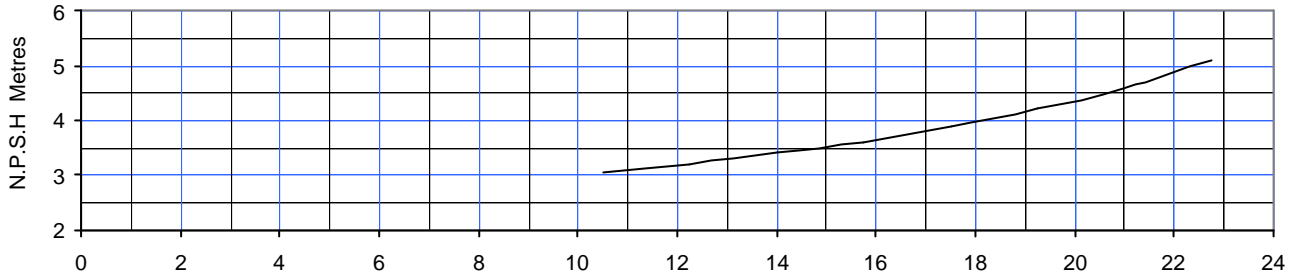

SUCTION DIA 65	DISCHARGE DIA 50	MAX PRESSURE 12 bar	PUMP MODEL TD 50-125	SPEED 2900
--------------------------	----------------------------	-------------------------------	--------------------------------	----------------------

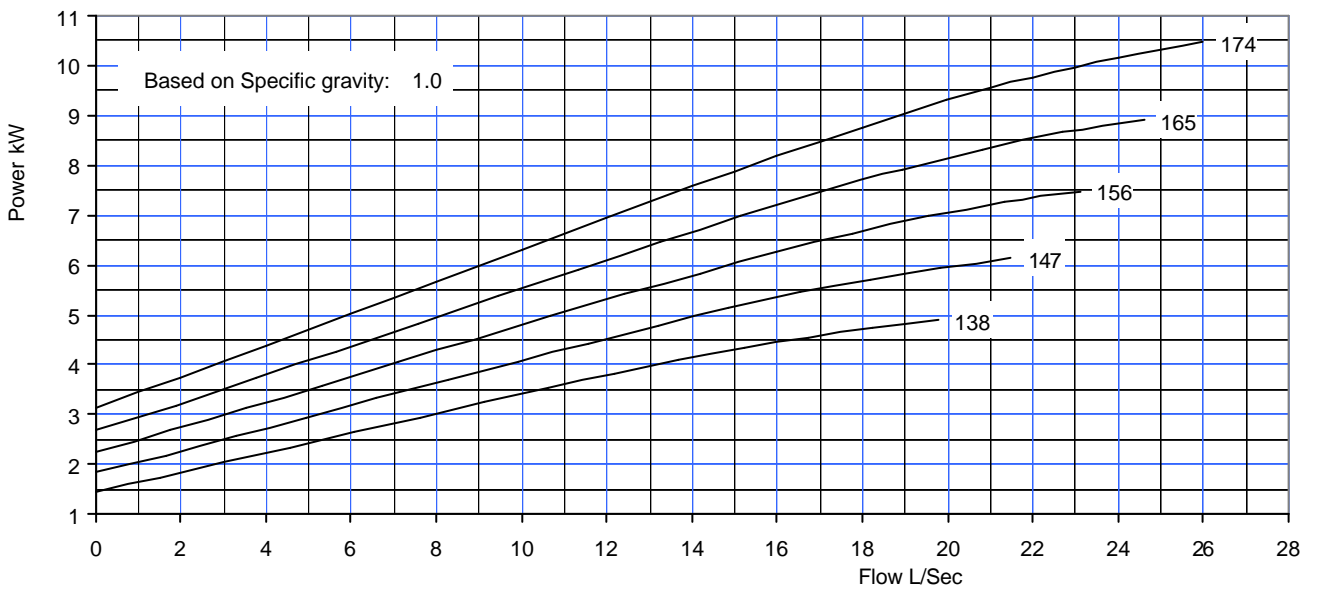
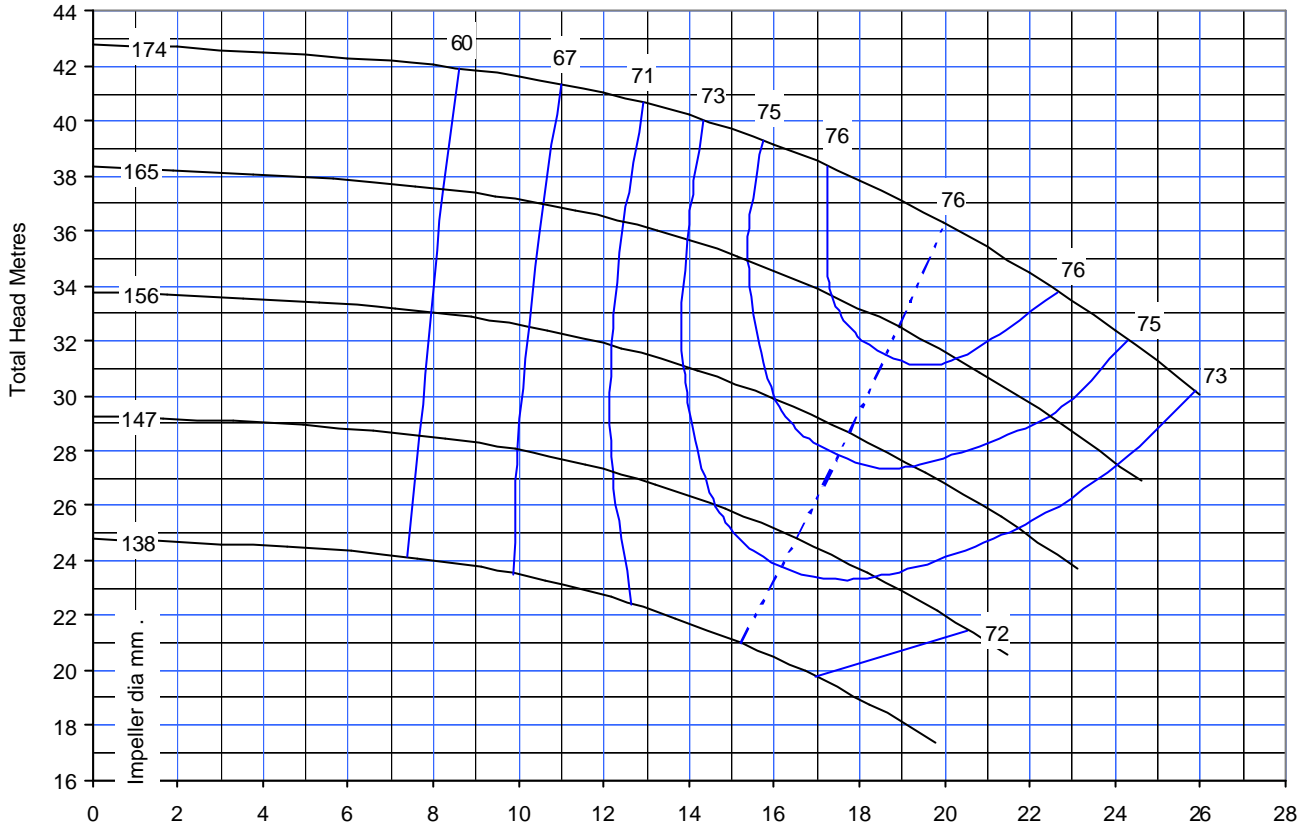
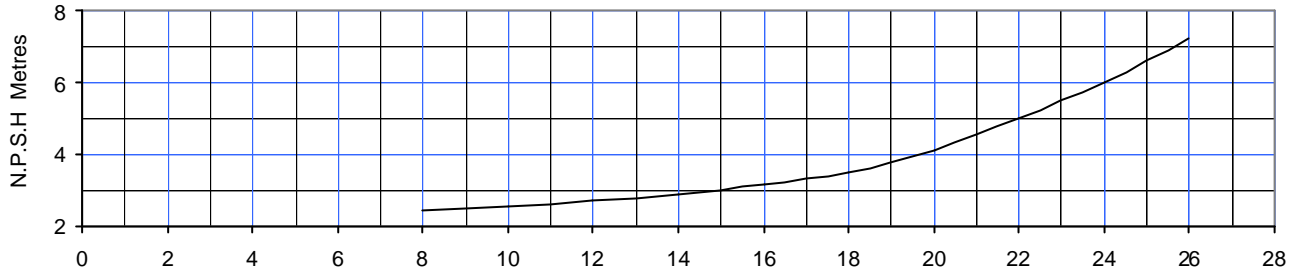

SUCTION DIA 65	DISCHARGE DIA 50	MAX PRESSURE 12 bar	PUMP MODEL TD 50-160	SPEED 2900
--------------------------	----------------------------	-------------------------------	--------------------------------	----------------------

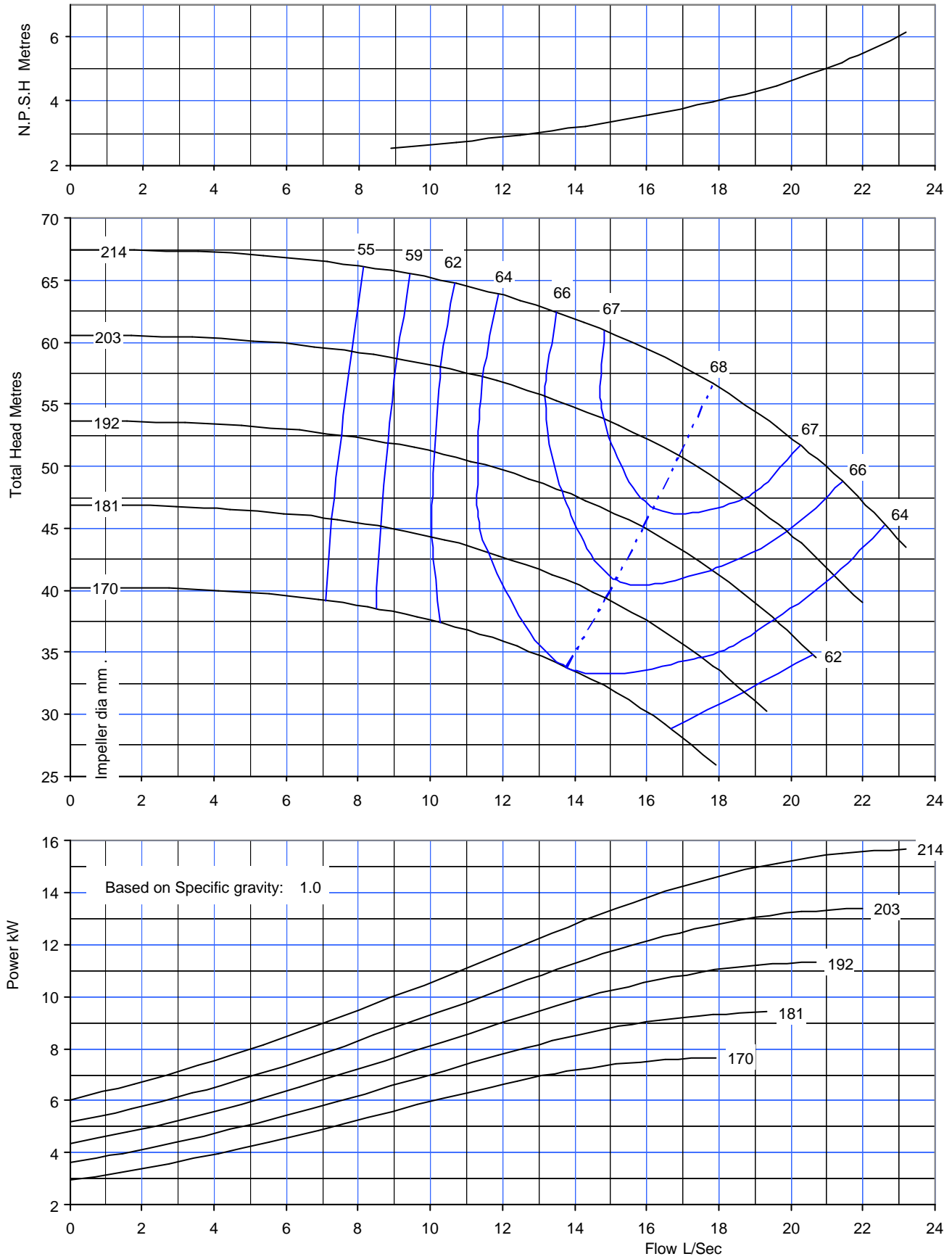

SUCTION DIA 65	DISCHARGE DIA 50	MAX PRESSURE 12 bar	PUMP MODEL TD 50-200	SPEED 2940
--------------------------	----------------------------	-------------------------------	--------------------------------	----------------------

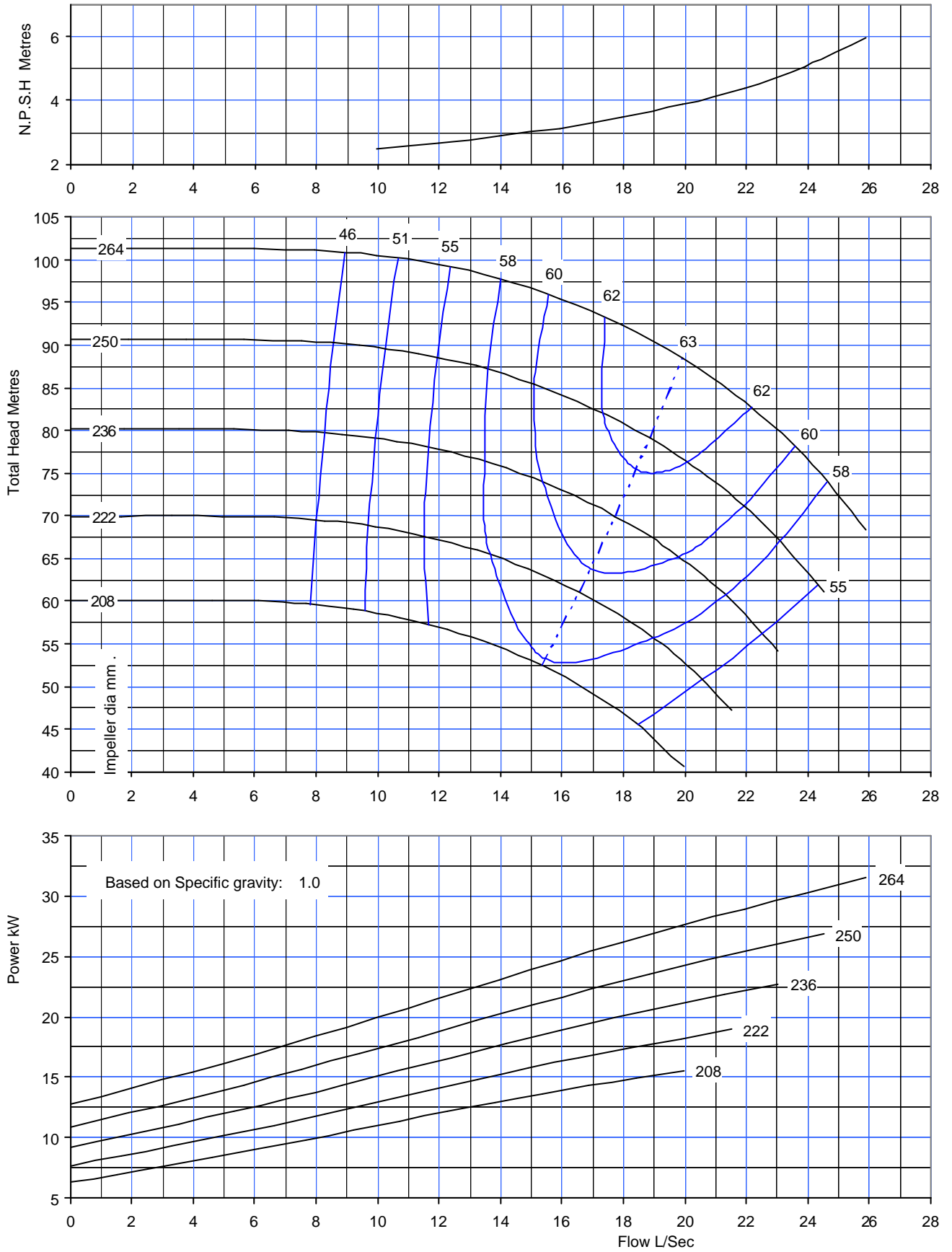

SUCTION DIA 65	DISCHARGE DIA 50	MAX PRESSURE 12 bar	PUMP MODEL TD 50-250	SPEED 2940
--------------------------	----------------------------	-------------------------------	--------------------------------	----------------------

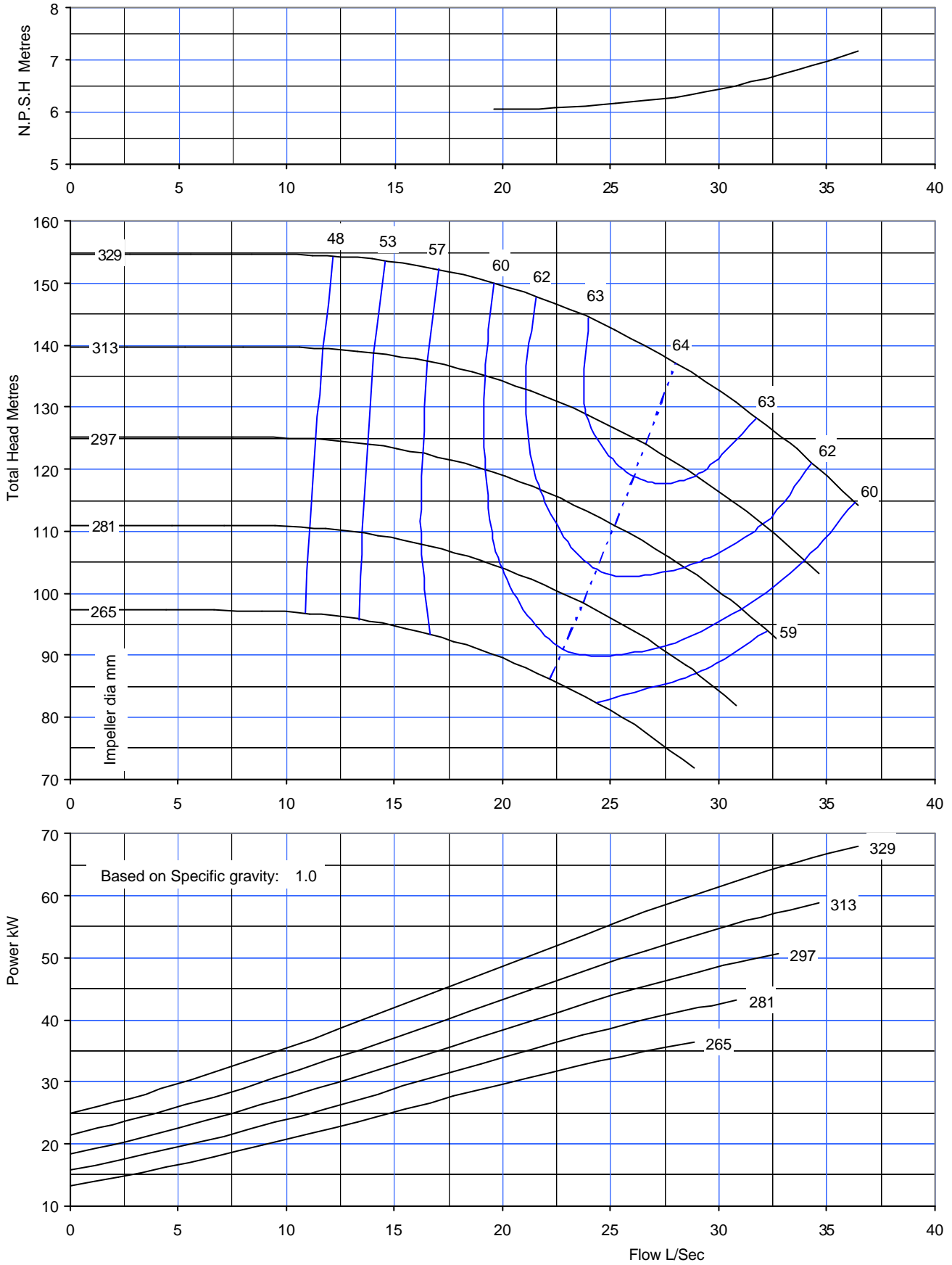

SUCTION DIA 65	DISCHARGE DIA 50	MAX PRESSURE 12 bar	PUMP MODEL TE 50-315	SPEED 2965
--------------------------	----------------------------	-------------------------------	--------------------------------	----------------------

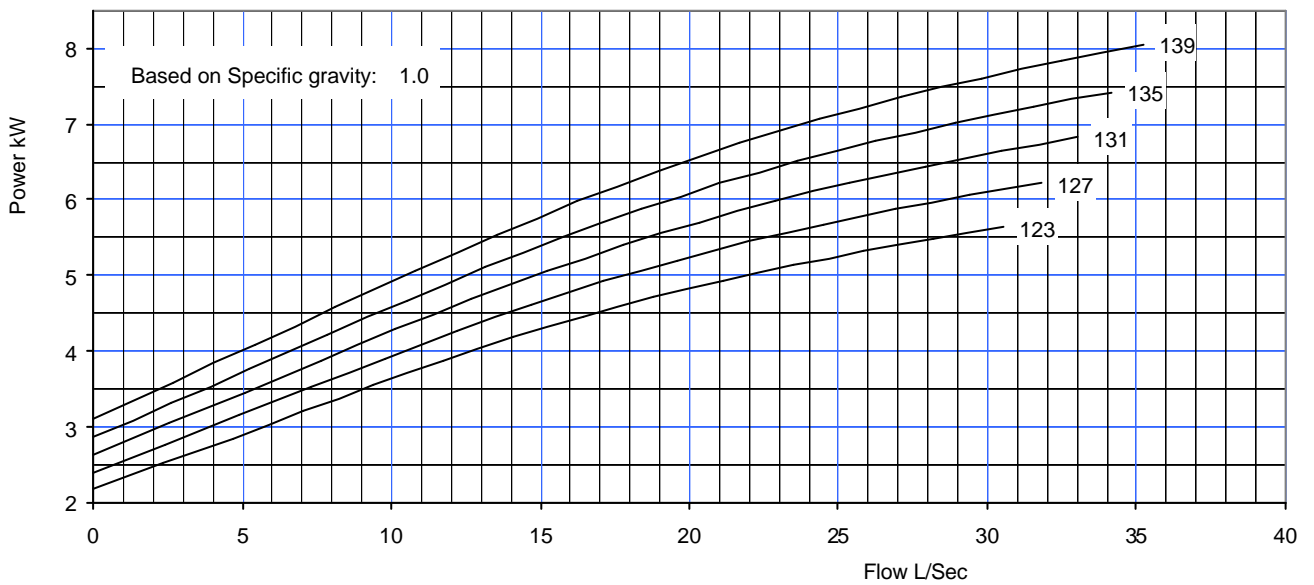
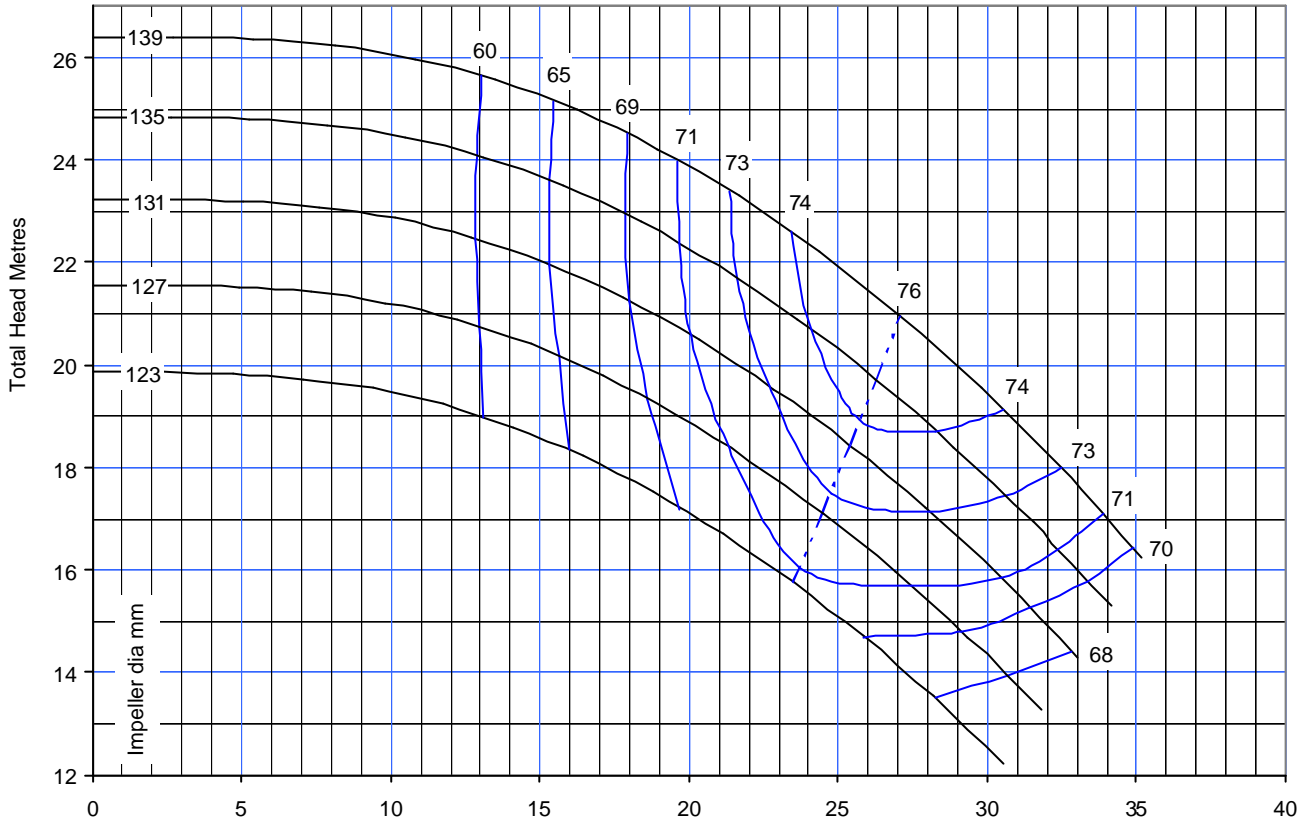
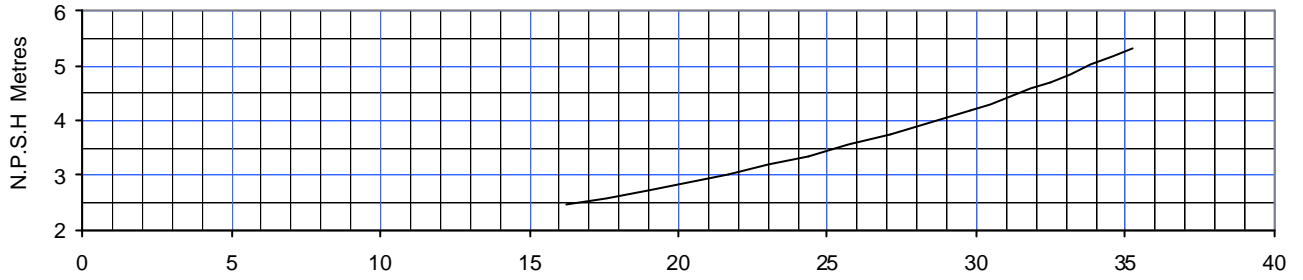

SUCTION DIA 80	DISCHARGE DIA 65	MAX PRESSURE 12 bar	PUMP MODEL TD 65-125	SPEED 2900
--------------------------	----------------------------	-------------------------------	--------------------------------	----------------------

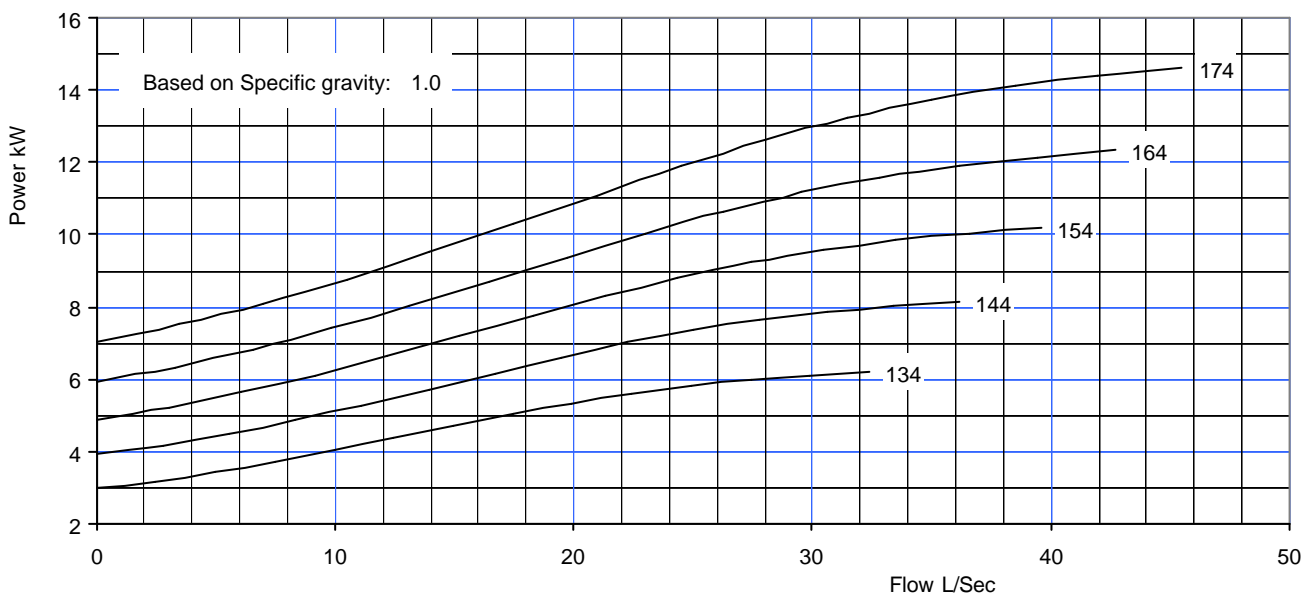
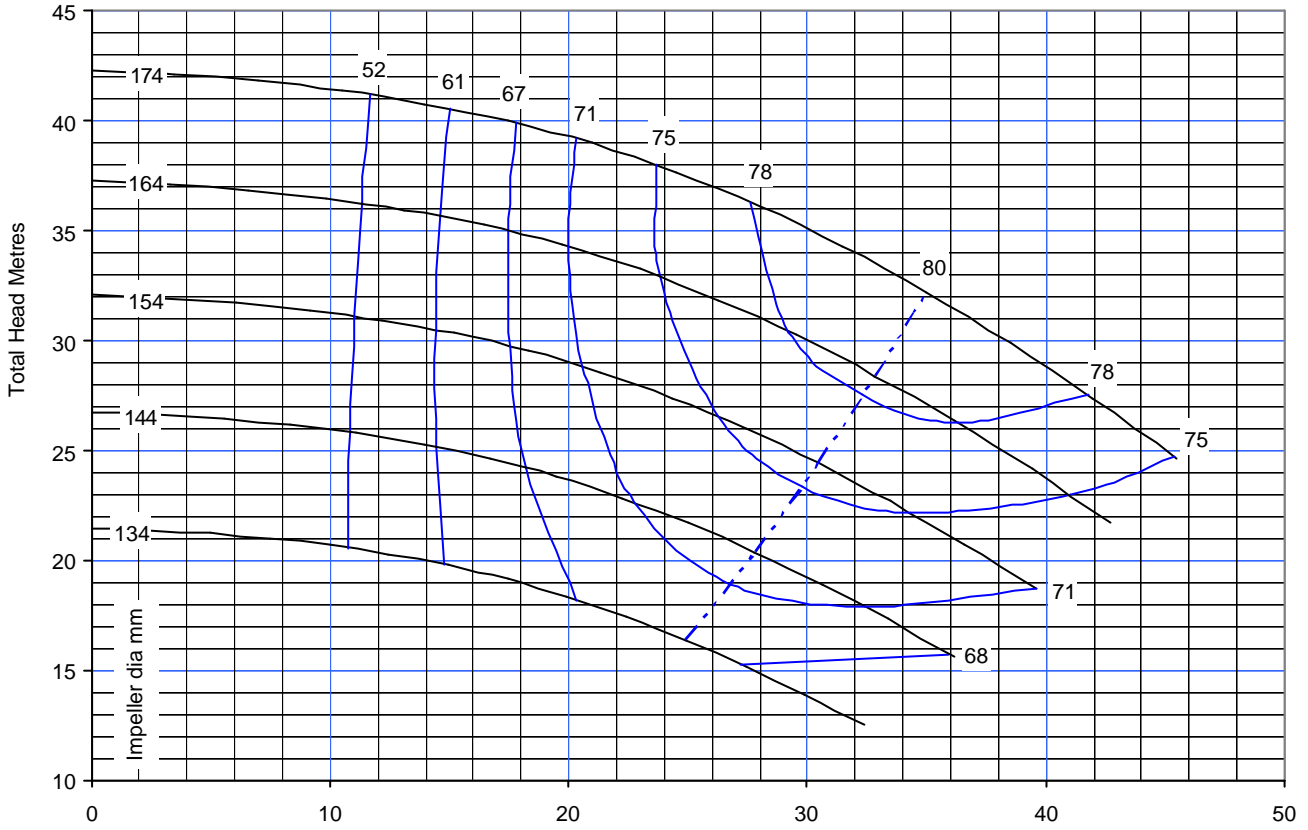
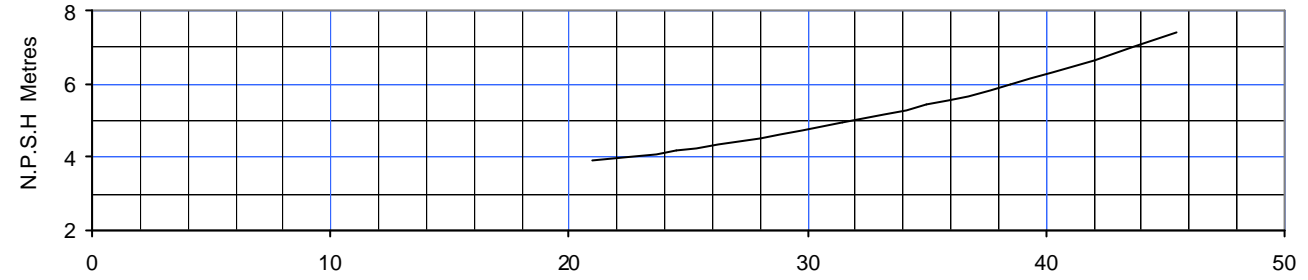

SUCTION DIA 80	DISCHARGE DIA 65	MAX PRESSURE 12 bar	PUMP MODEL TD 65-160	SPEED 2900
--------------------------	----------------------------	-------------------------------	--------------------------------	----------------------

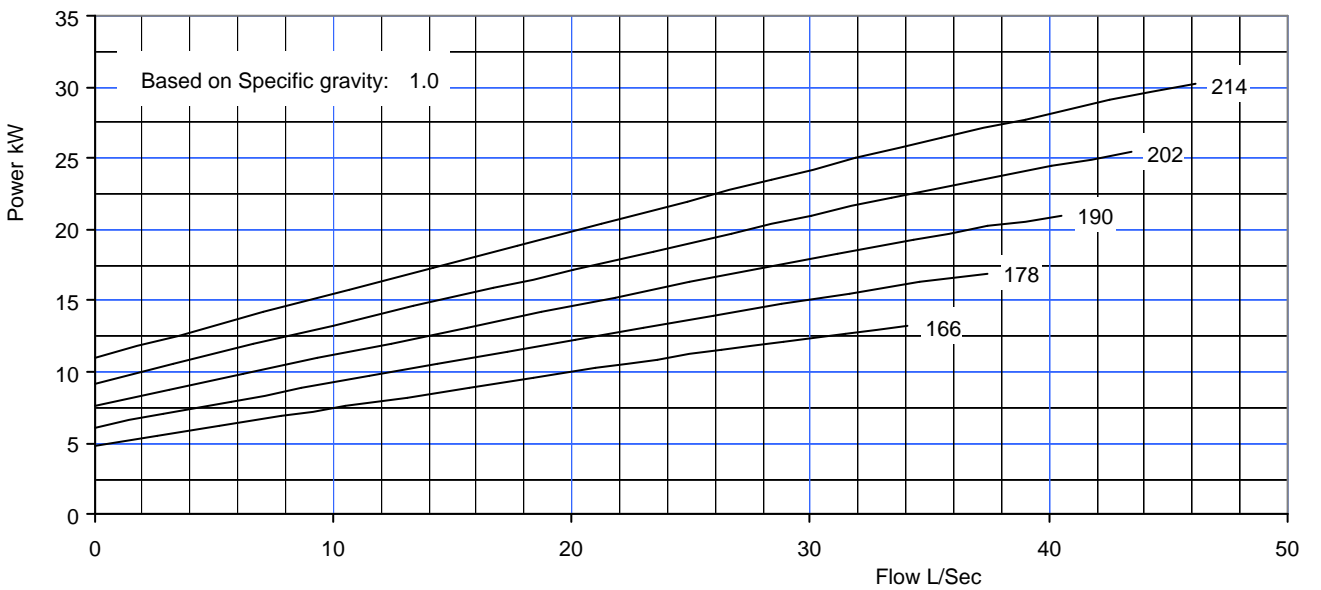
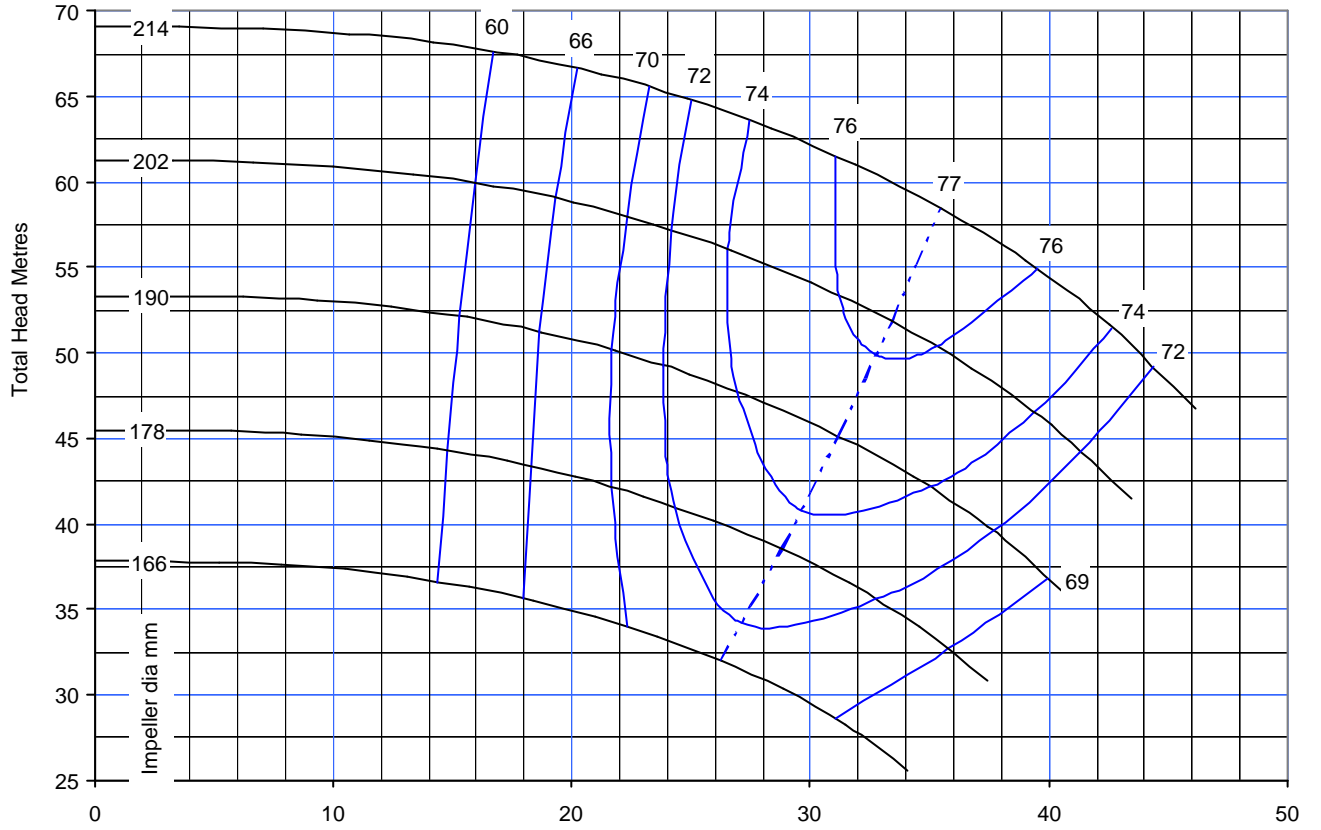
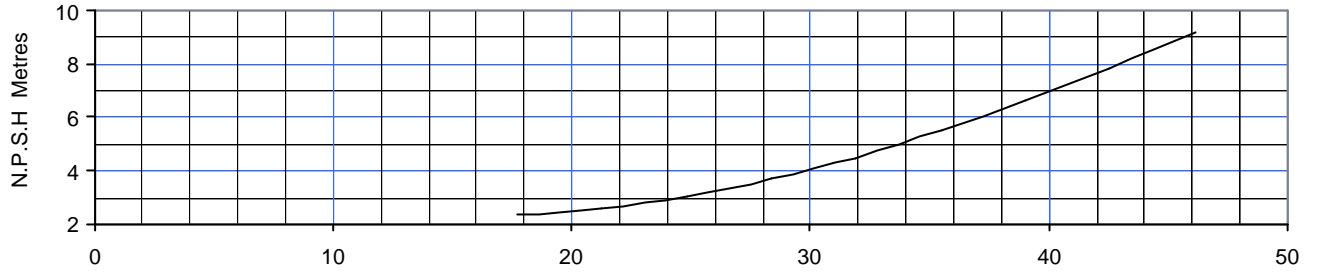

SUCTION DIA 80	DISCHARGE DIA 65	MAX PRESSURE 12 bar	PUMP MODEL TD 65-200	SPEED 2940
--------------------------	----------------------------	-------------------------------	--------------------------------	----------------------

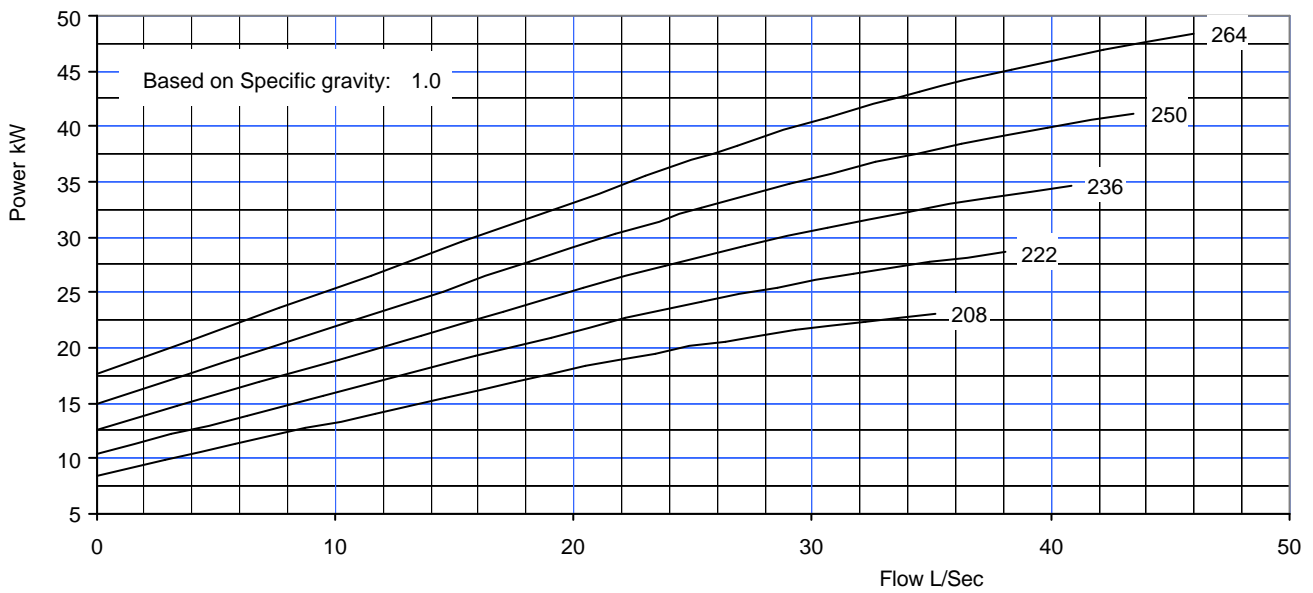
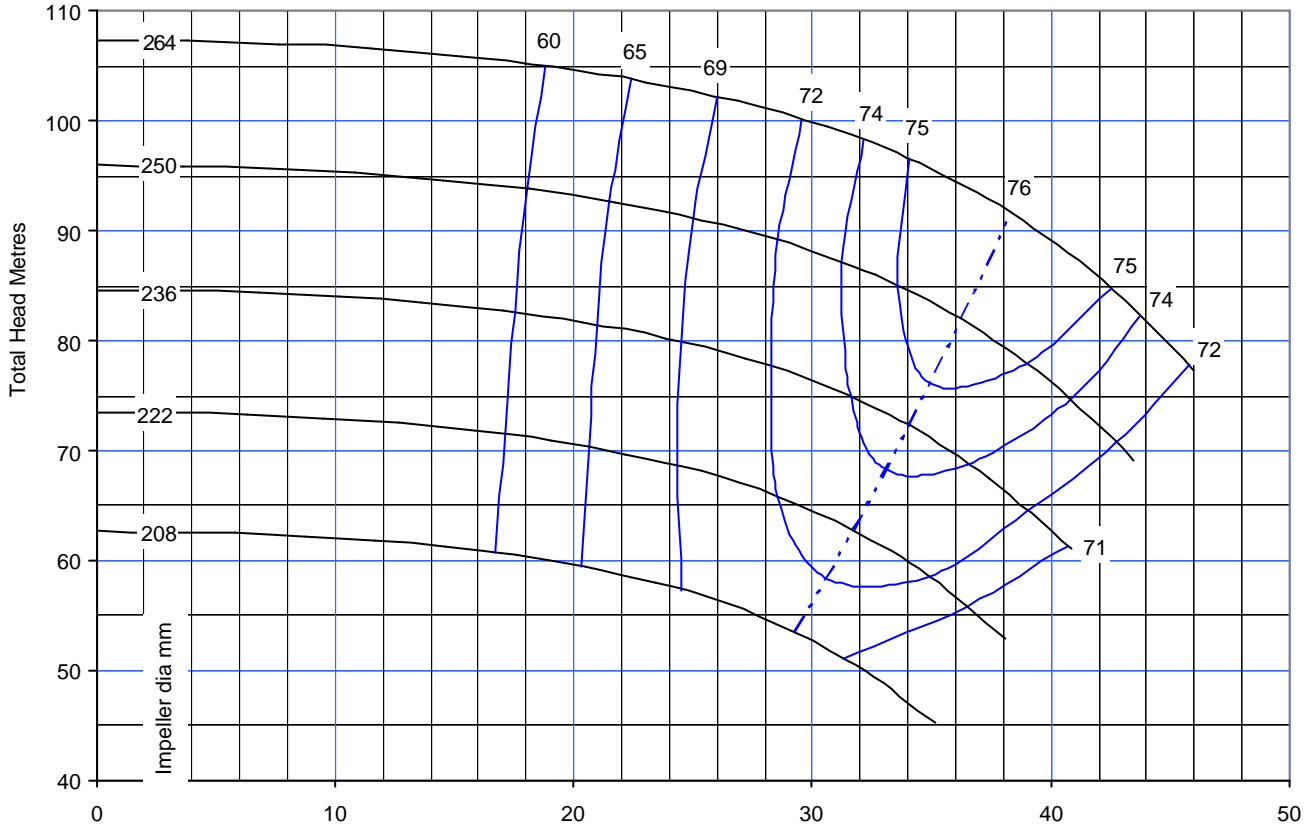
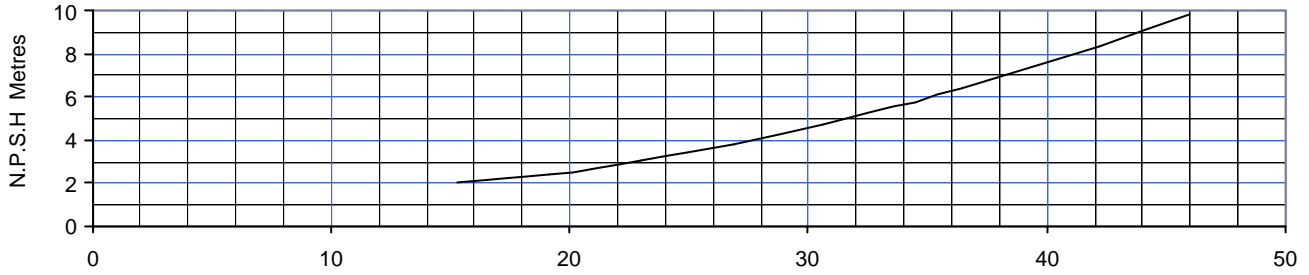

SUCTION DIA 80	DISCHARGE DIA 65	MAX PRESSURE 12 bar	PUMP MODEL TD 65-250	SPEED 2965
--------------------------	----------------------------	-------------------------------	--------------------------------	----------------------

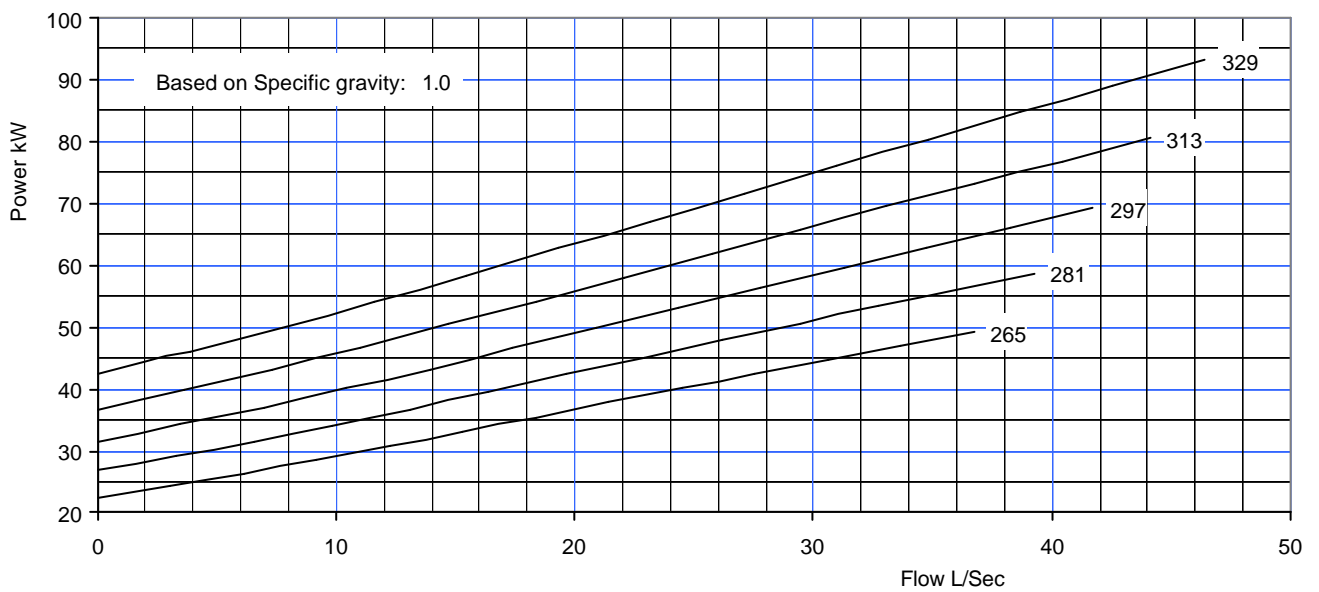
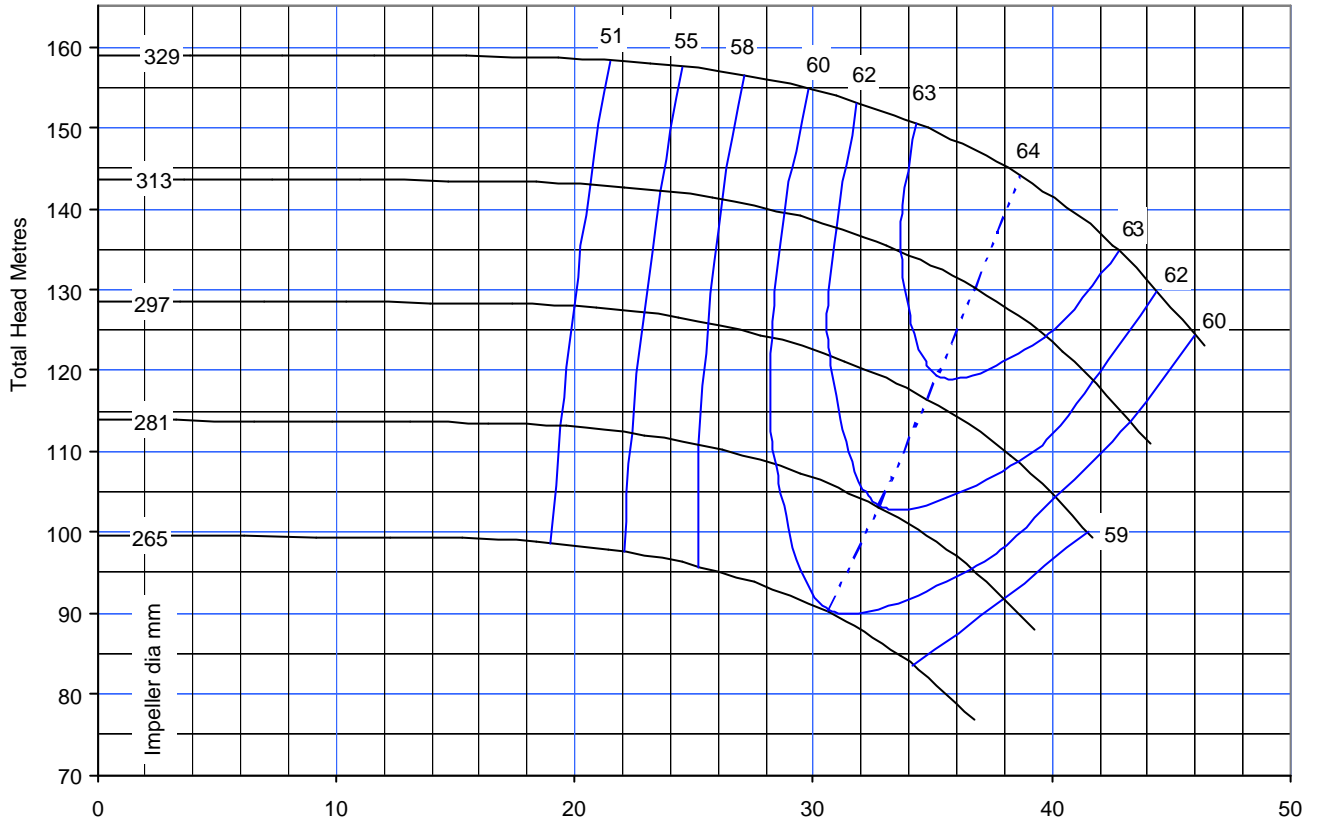
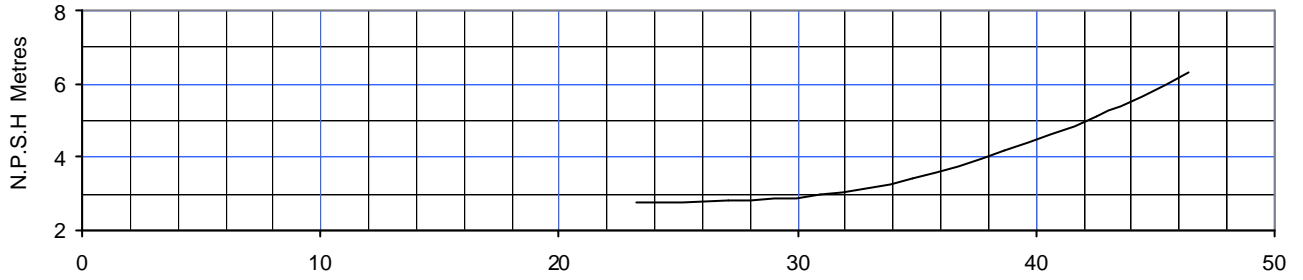

SUCTION DIA 80	DISCHARGE DIA 65	MAX PRESSURE 16 bar	PUMP MODEL TE 65-315	SPEED 2970
--------------------------	----------------------------	-------------------------------	--------------------------------	----------------------

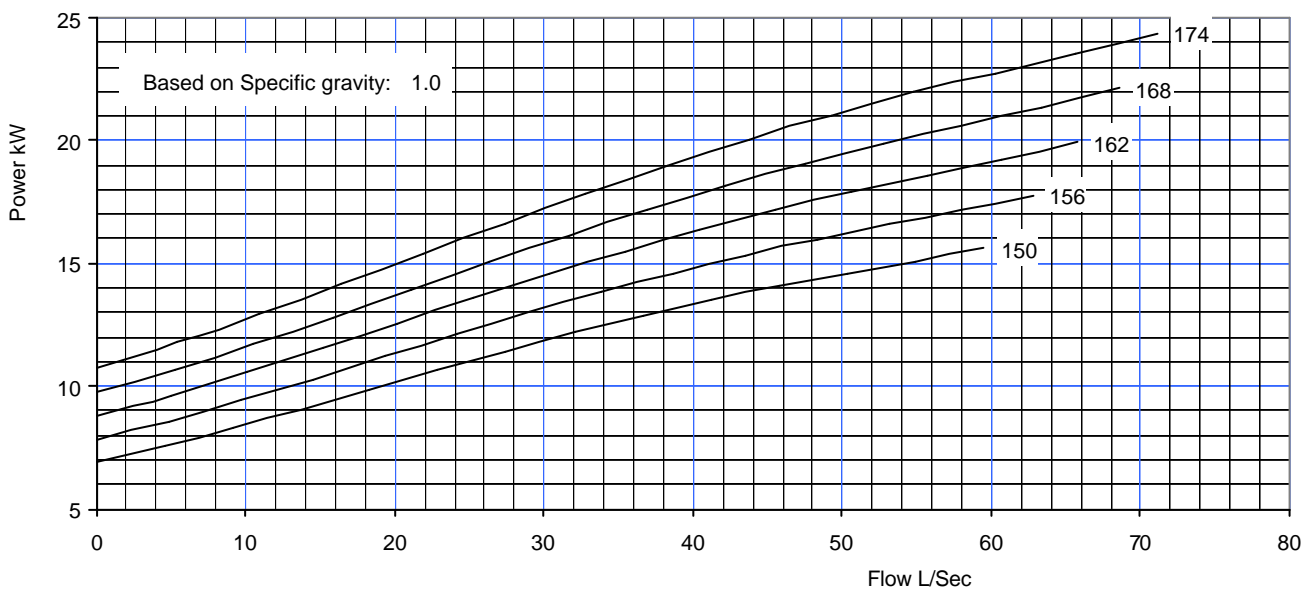
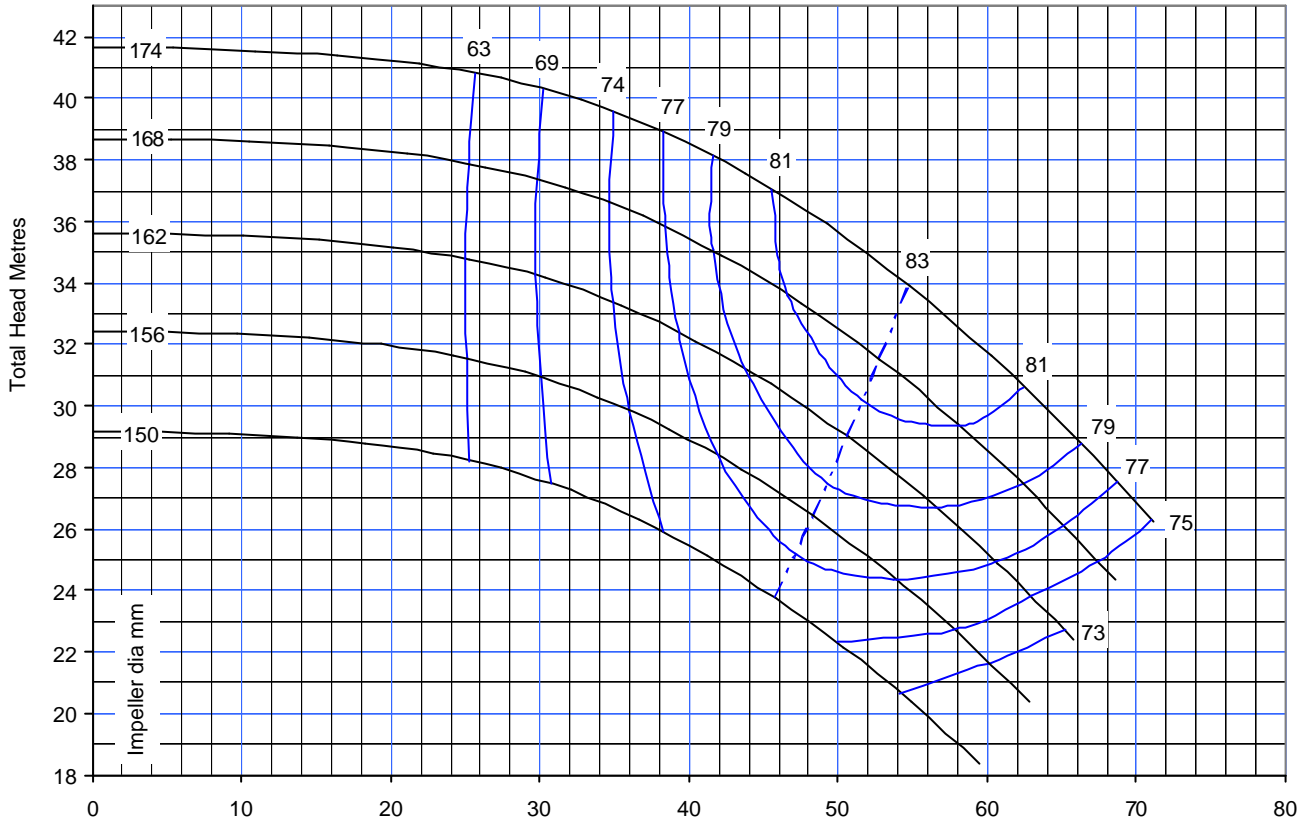
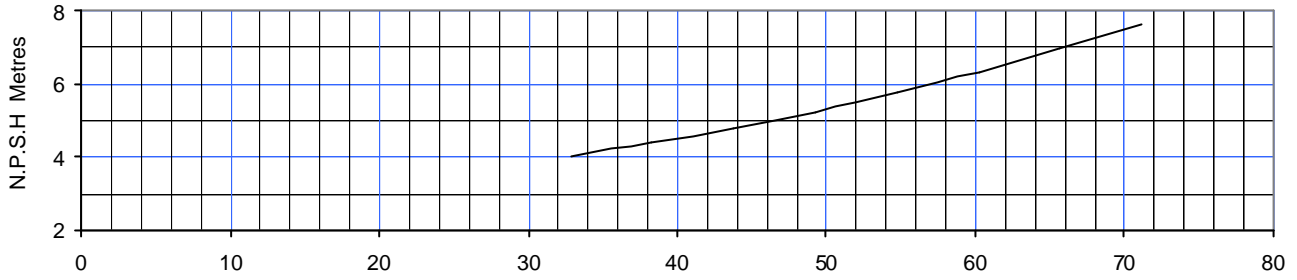

SUCTION DIA 100	DISCHARGE DIA 80	MAX PRESSURE 12 bar	PUMP MODEL TD 80-160	SPEED 2940
---------------------------	----------------------------	-------------------------------	--------------------------------	----------------------

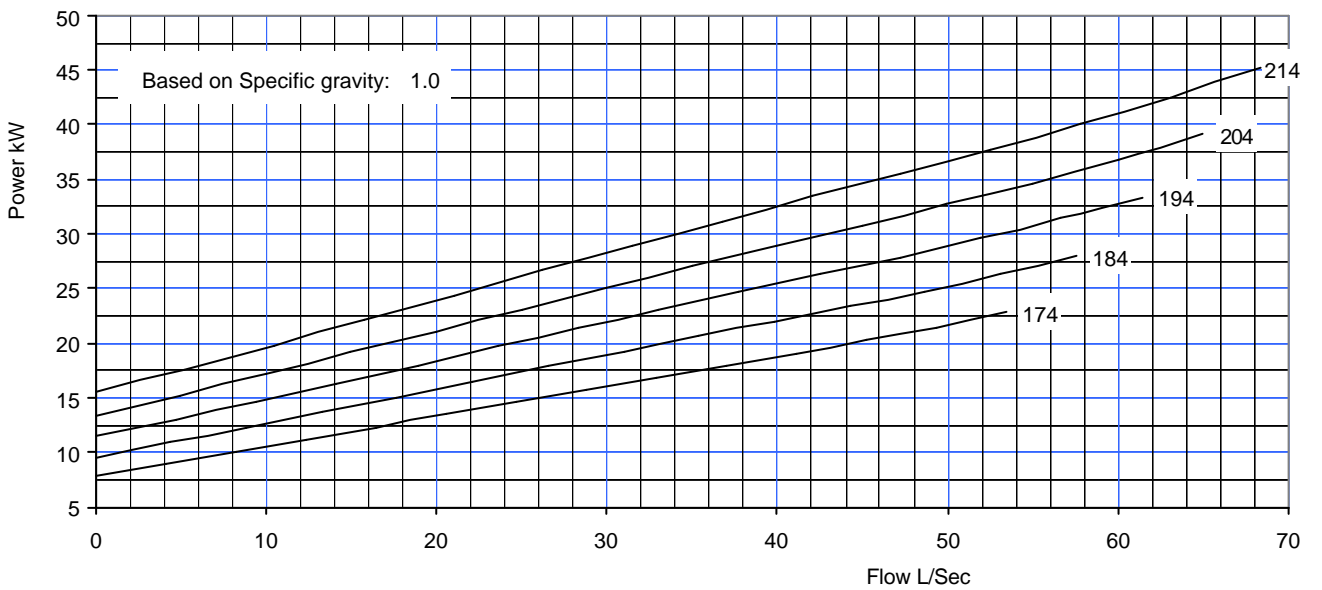
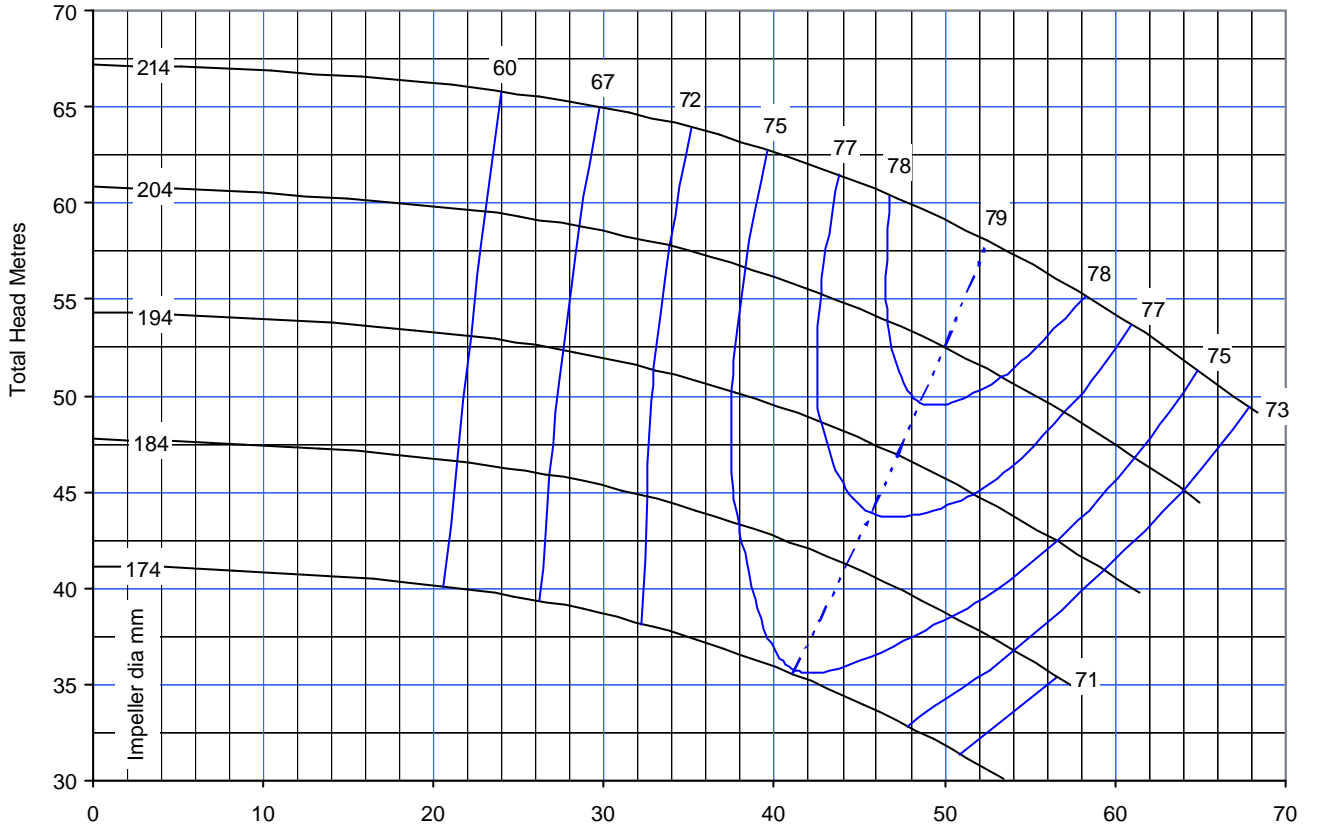
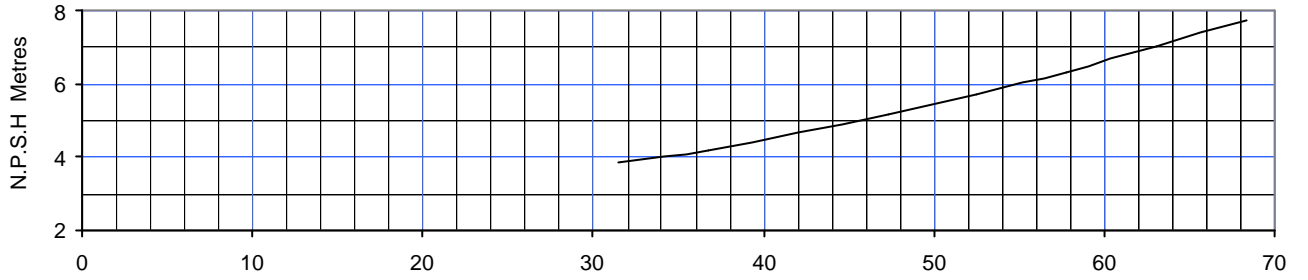

SUCTION DIA 100	DISCHARGE DIA 80	MAX PRESSURE 12 bar	PUMP MODEL TD 80-200	SPEED 2965
---------------------------	----------------------------	-------------------------------	--------------------------------	----------------------

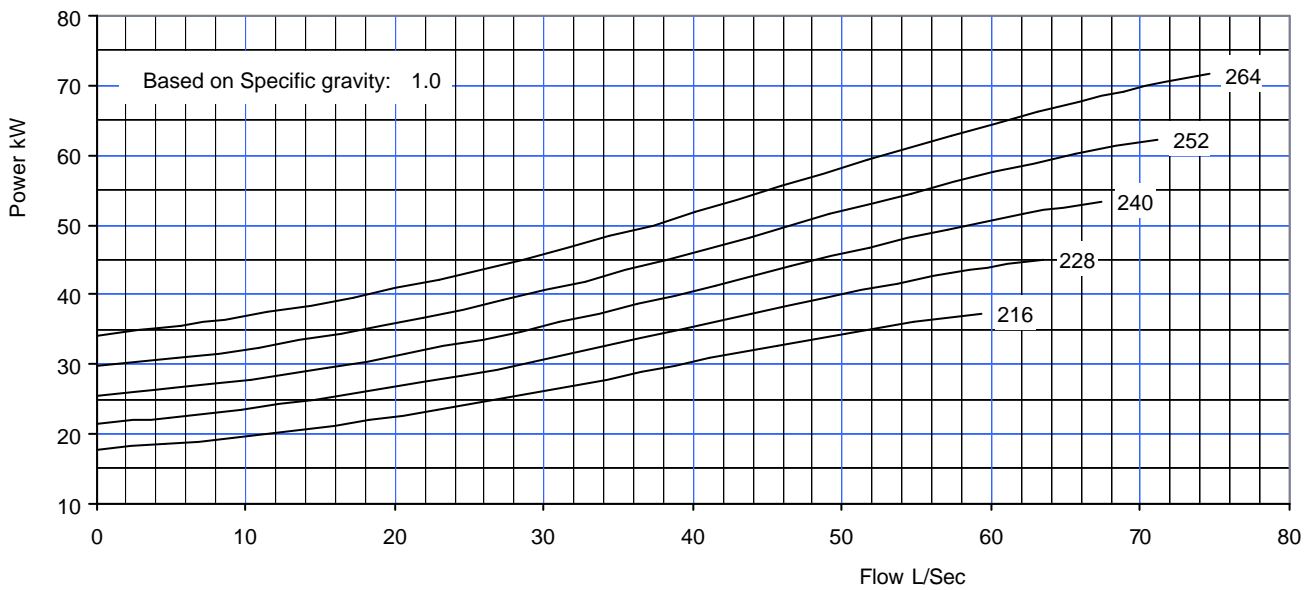
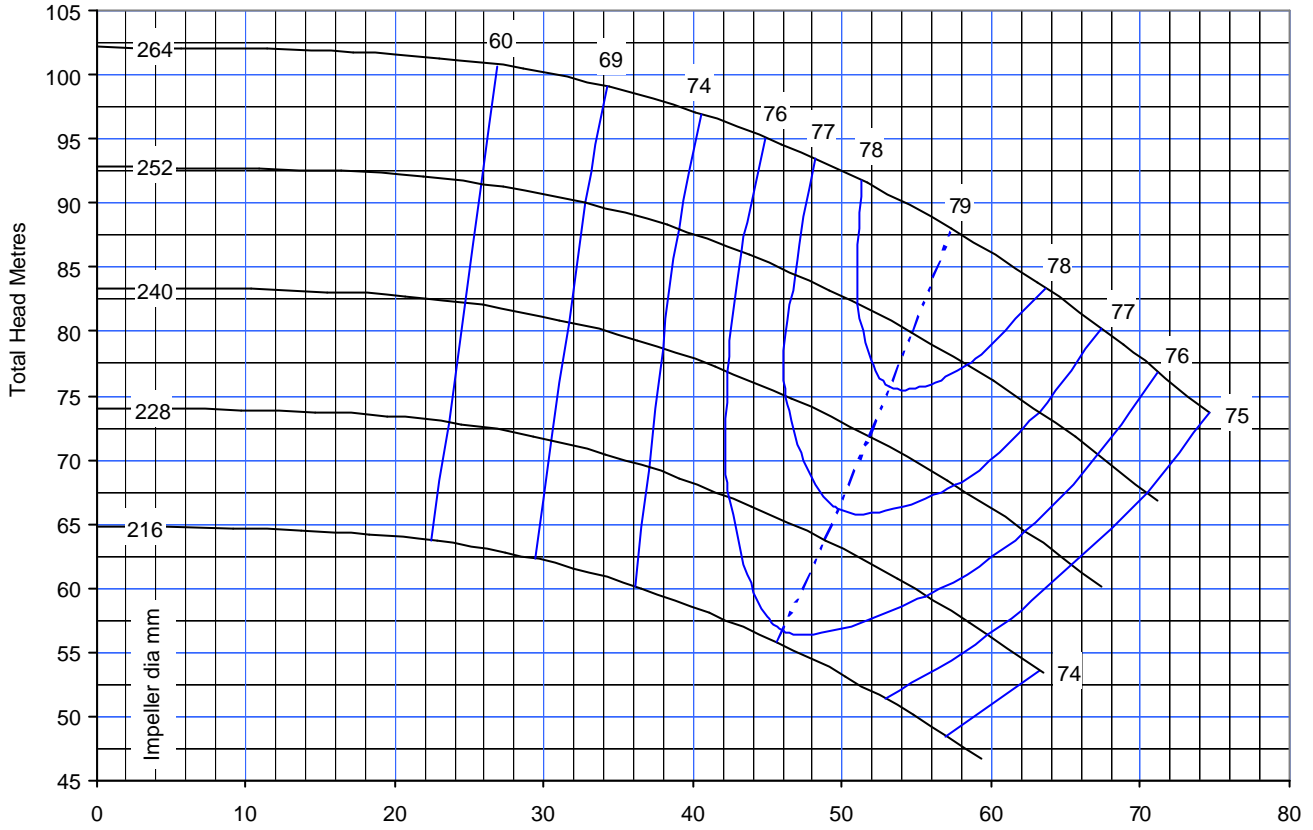
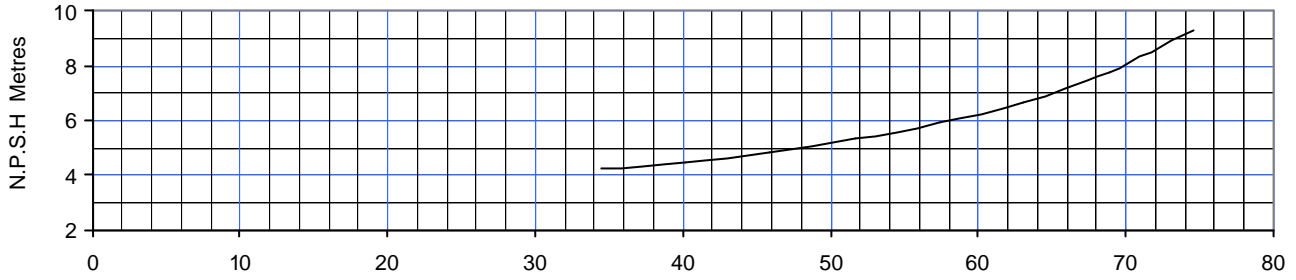

SUCTION DIA 100	DISCHARGE DIA 80	MAX PRESSURE 12 bar	PUMP MODEL TD 80-250	SPEED 2965
---------------------------	----------------------------	-------------------------------	--------------------------------	----------------------

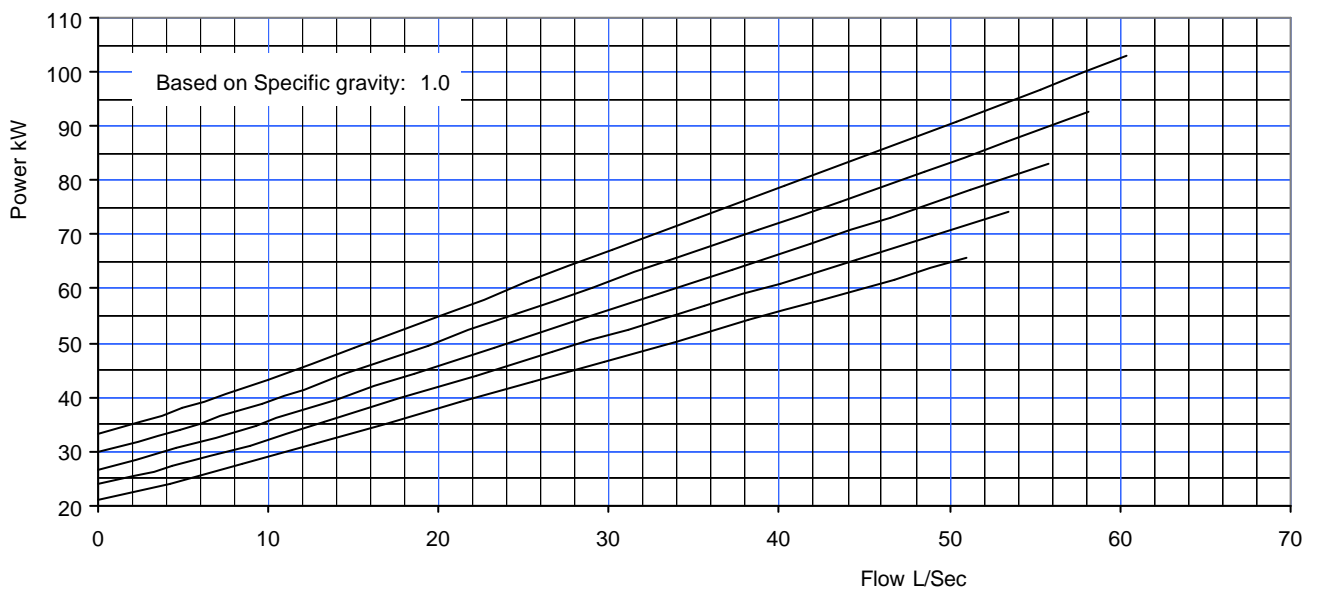
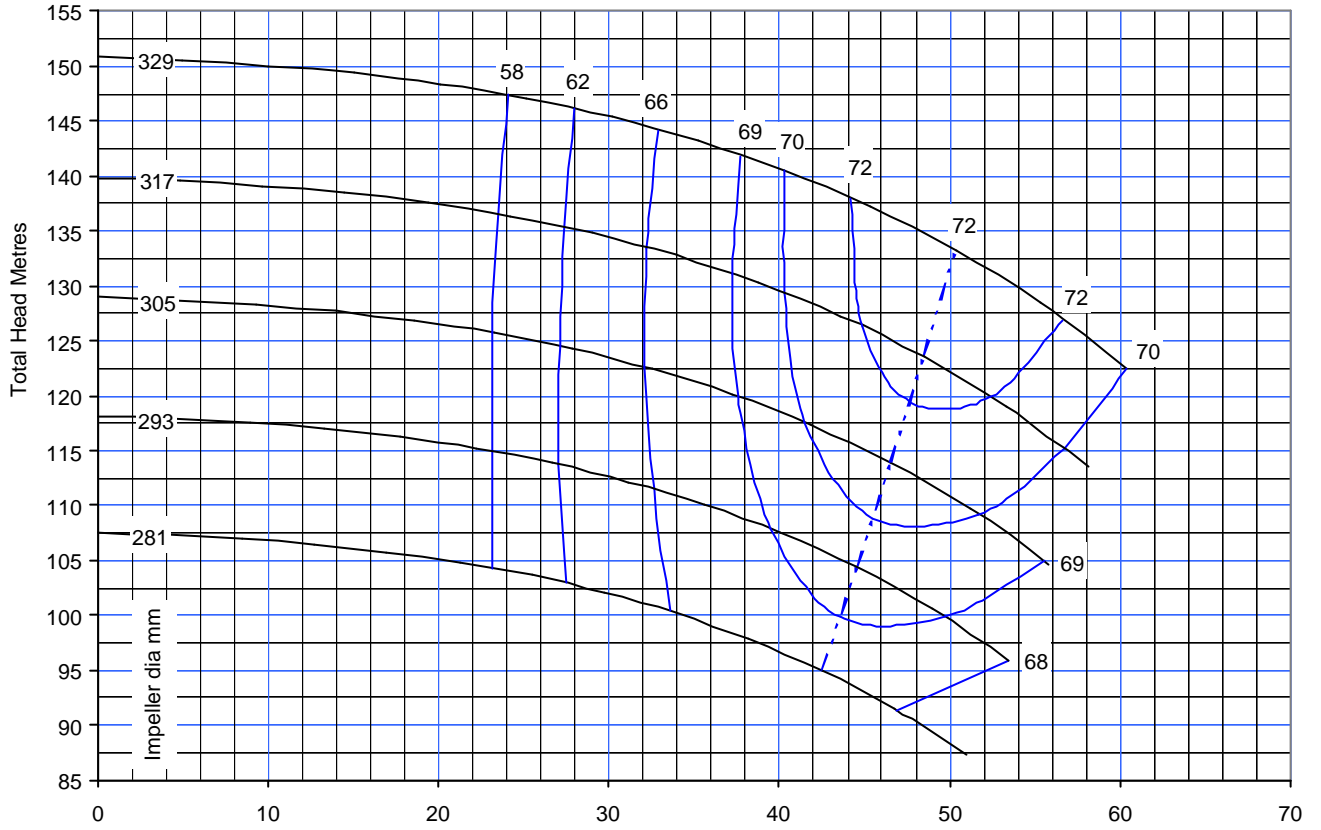
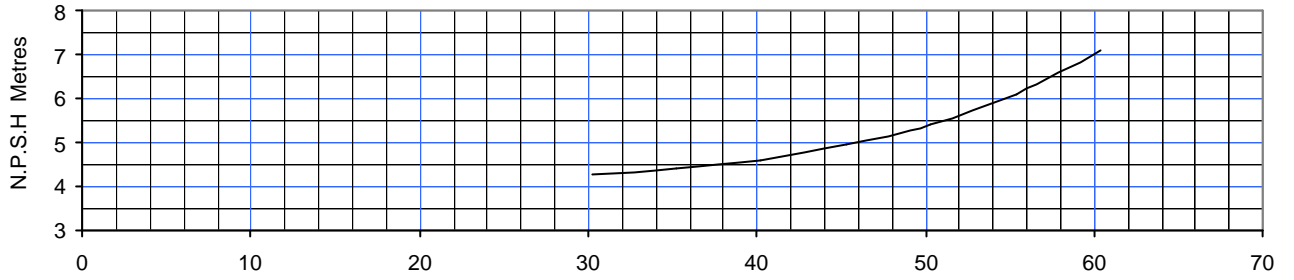

SUCTION DIA 100	DISCHARGE DIA 80	MAX PRESSURE 16 bar	PUMP MODEL TE 80-315	SPEED 2970
---------------------------	----------------------------	-------------------------------	--------------------------------	----------------------

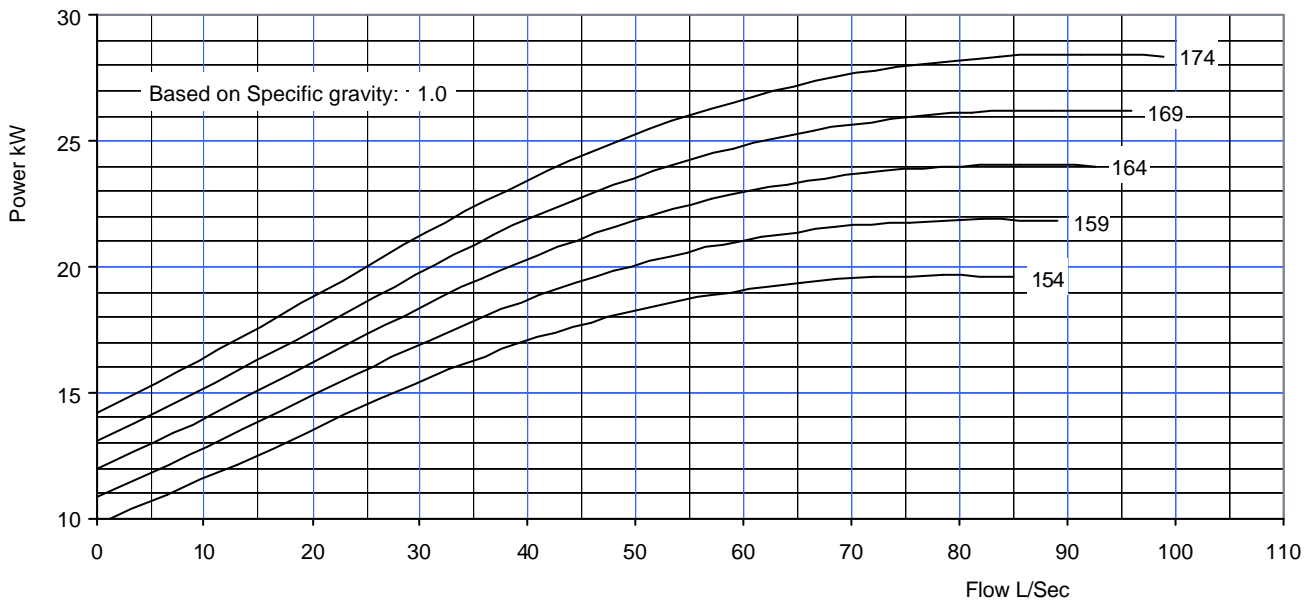
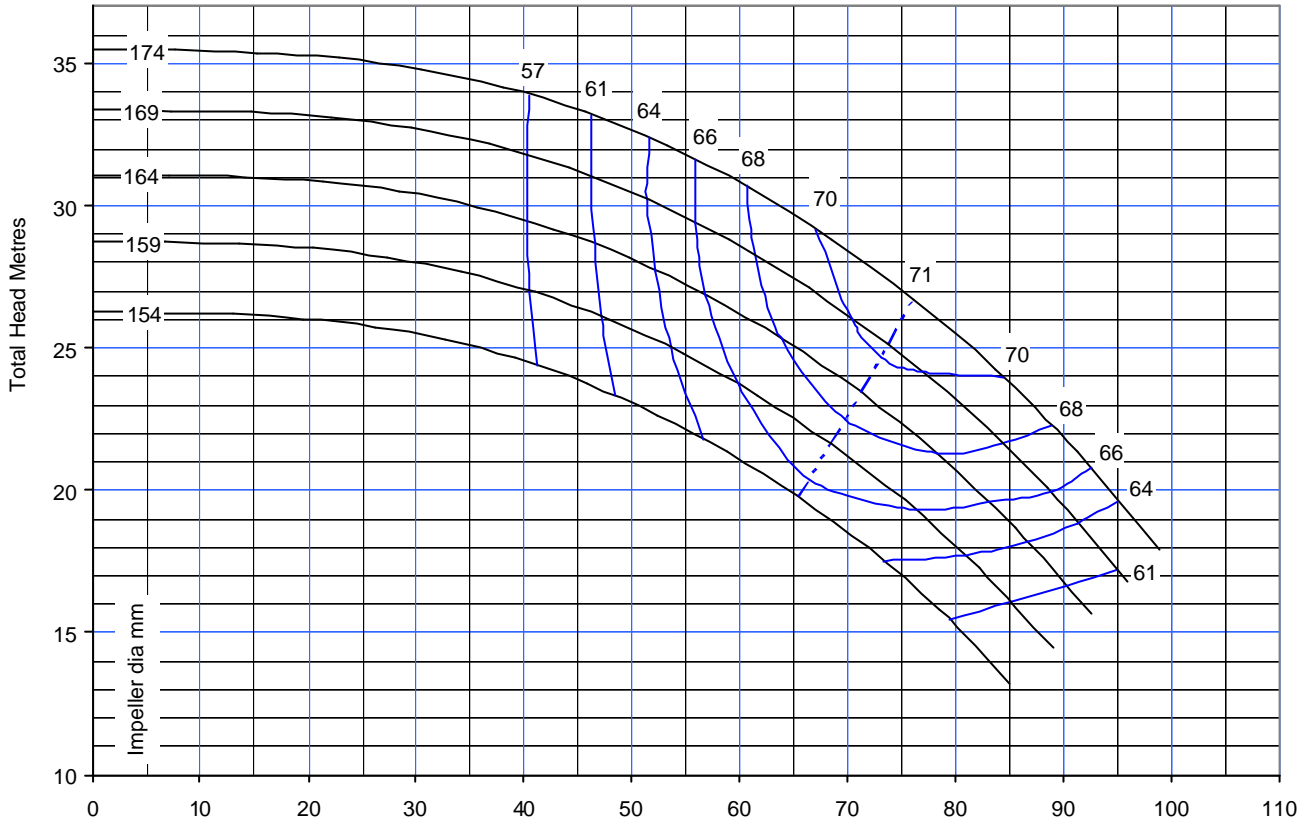
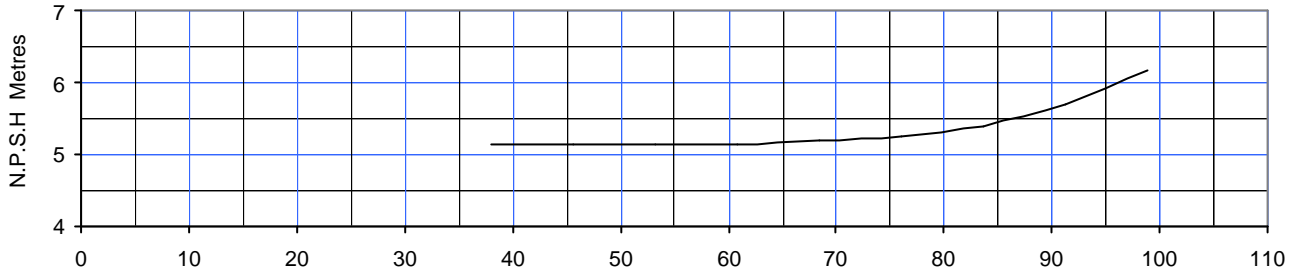

SUCTION DIA 125	DISCHARGE DIA 100	MAX PRESSURE 12 bar	PUMP MODEL TD 100-160	SPEED 2940
---------------------------	-----------------------------	-------------------------------	---------------------------------	----------------------

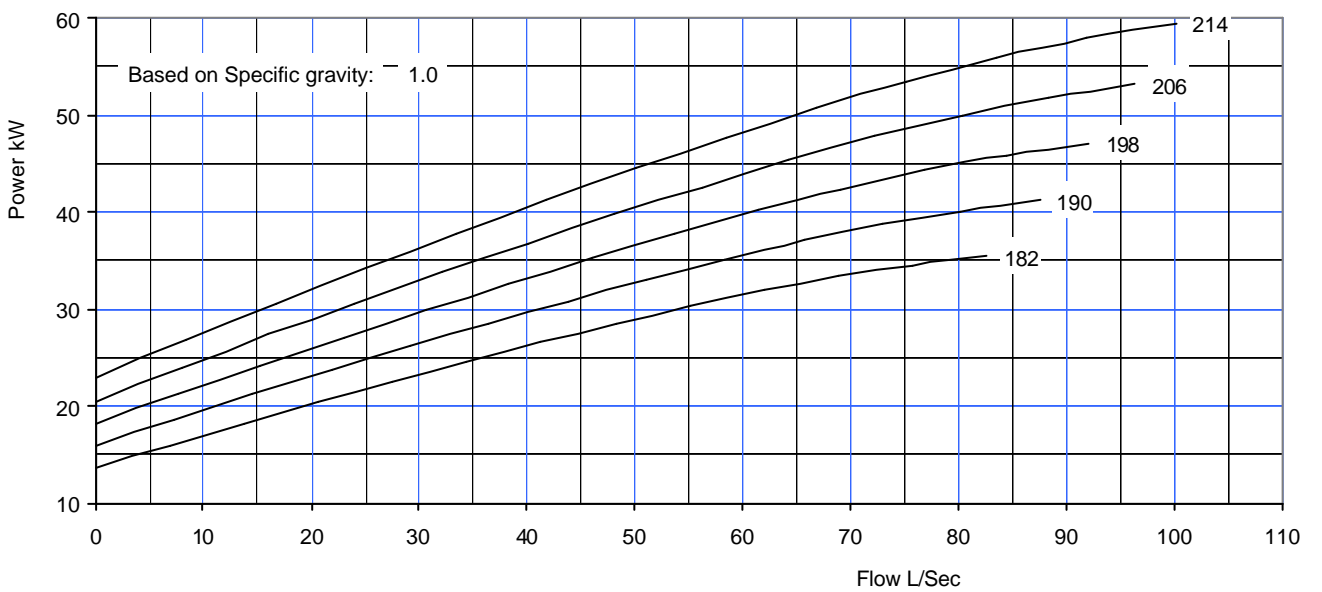
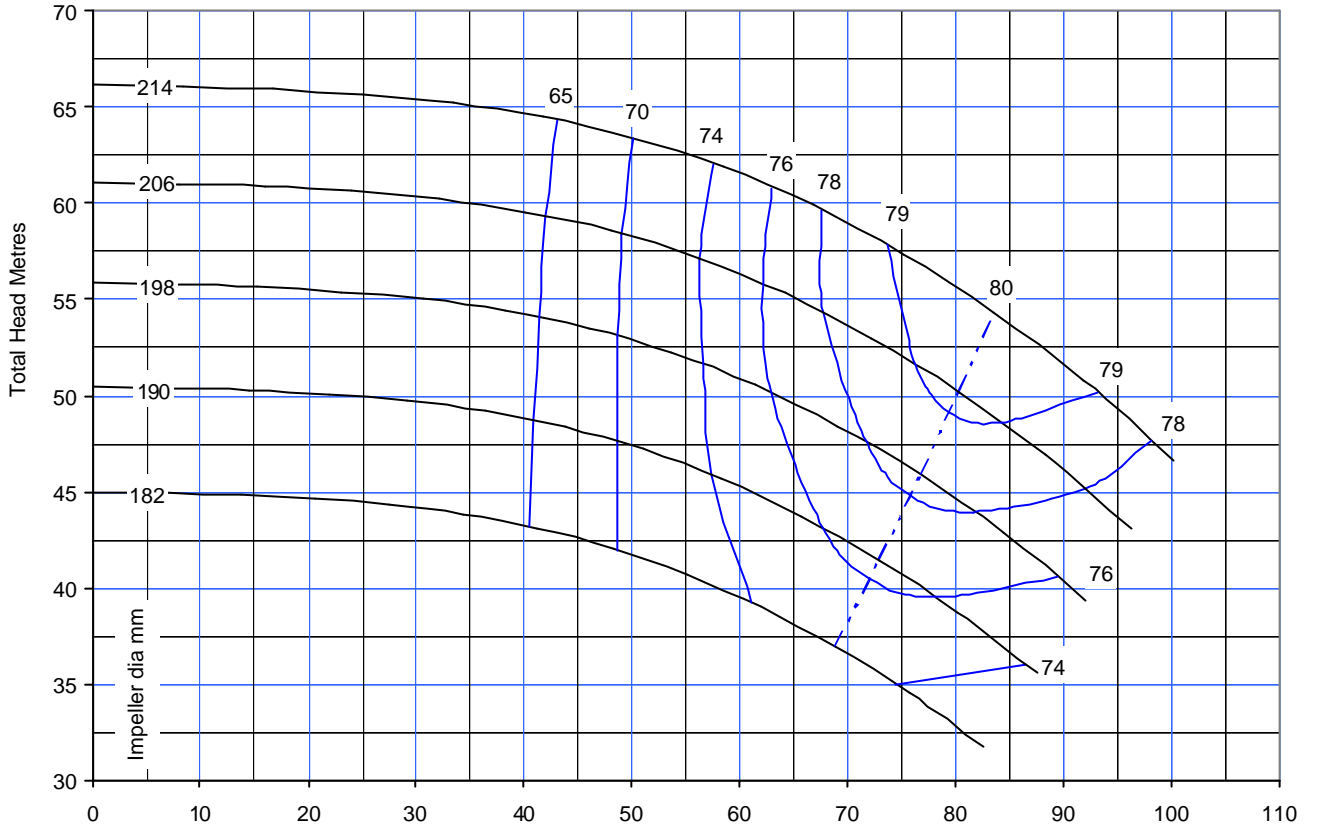
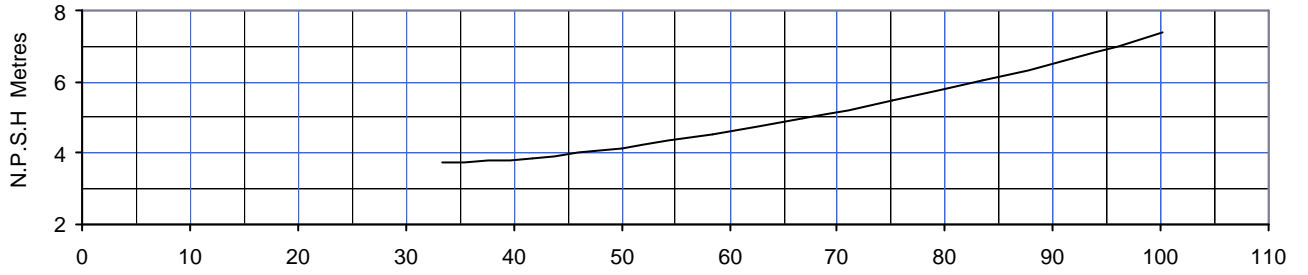

SUCTION DIA 125	DISCHARGE DIA 100	MAX PRESSURE 12 bar	PUMP MODEL TD 100-200	SPEED 2965
---------------------------	-----------------------------	-------------------------------	---------------------------------	----------------------

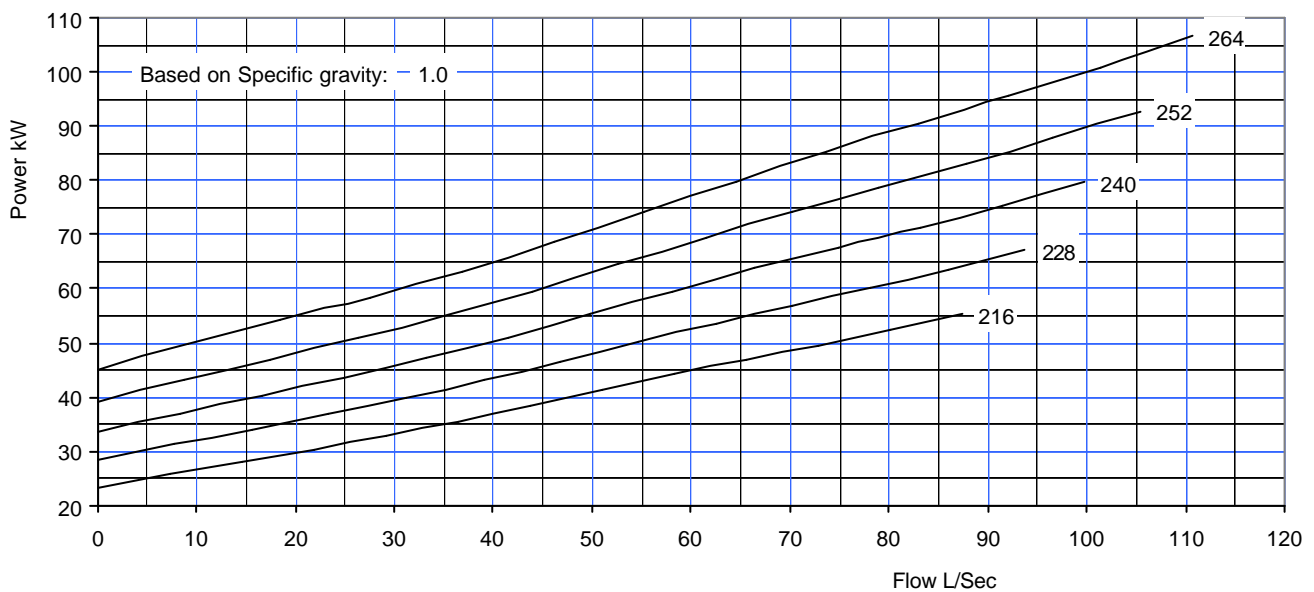
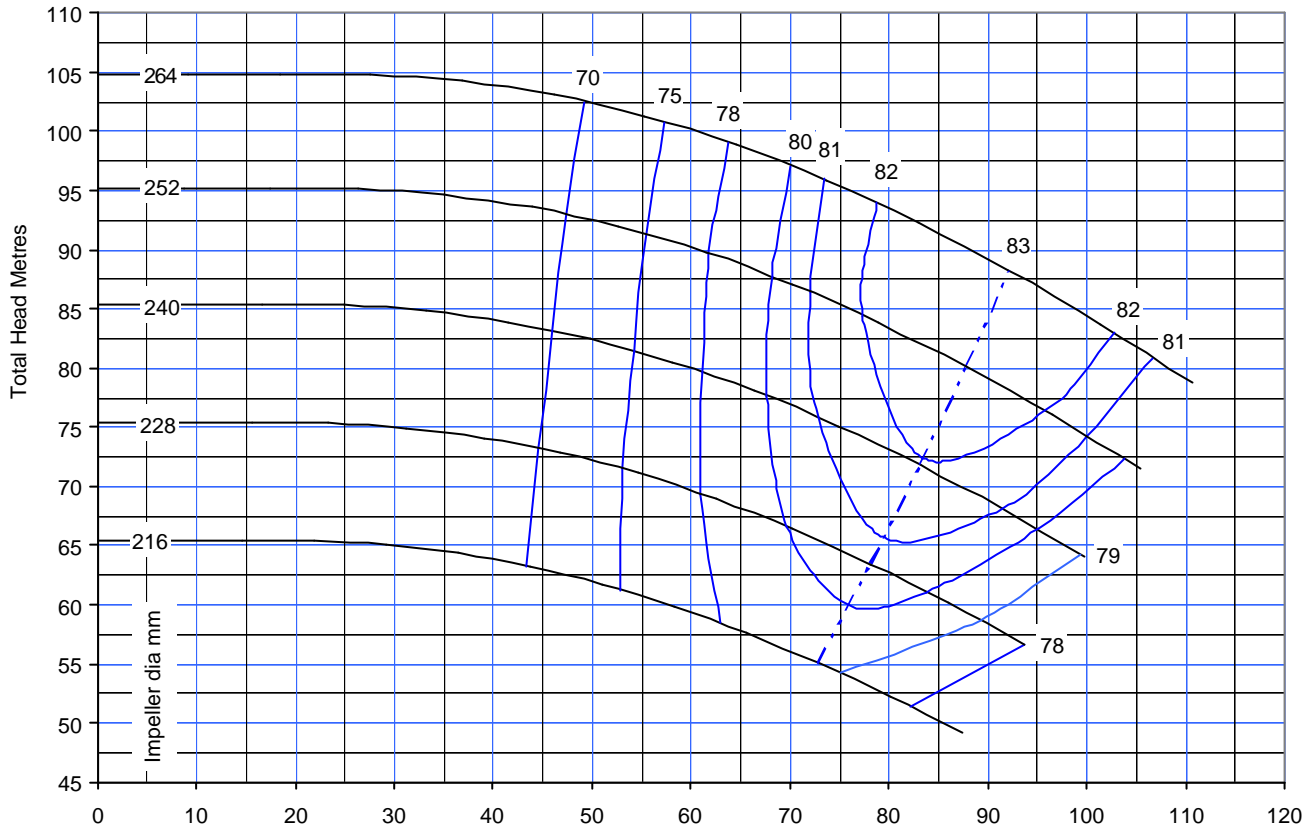
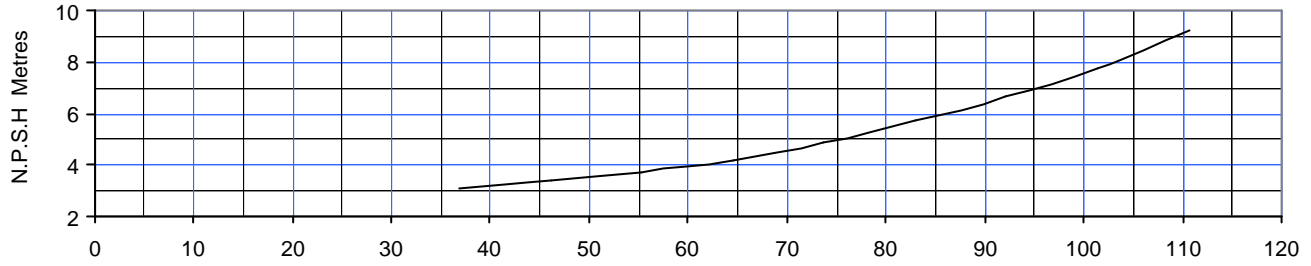

SUCTION DIA 125	DISCHARGE DIA 100	MAX PRESSURE 12 bar	PUMP MODEL TE 100-250	SPEED 2970
---------------------------	-----------------------------	-------------------------------	---------------------------------	----------------------

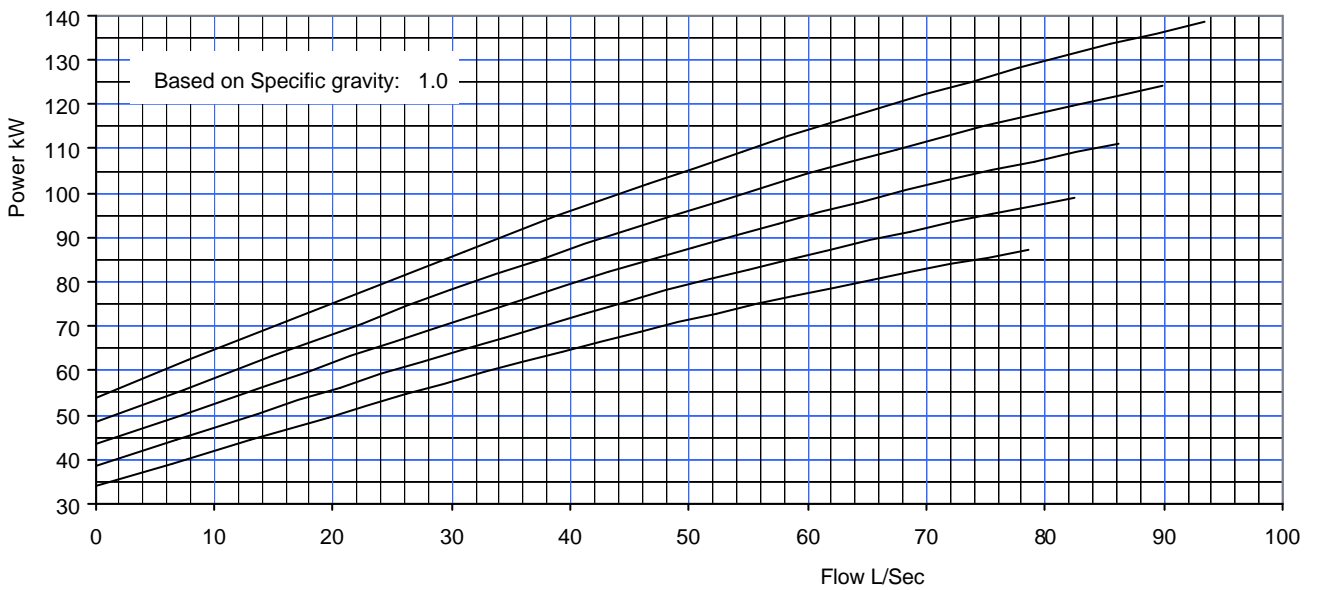
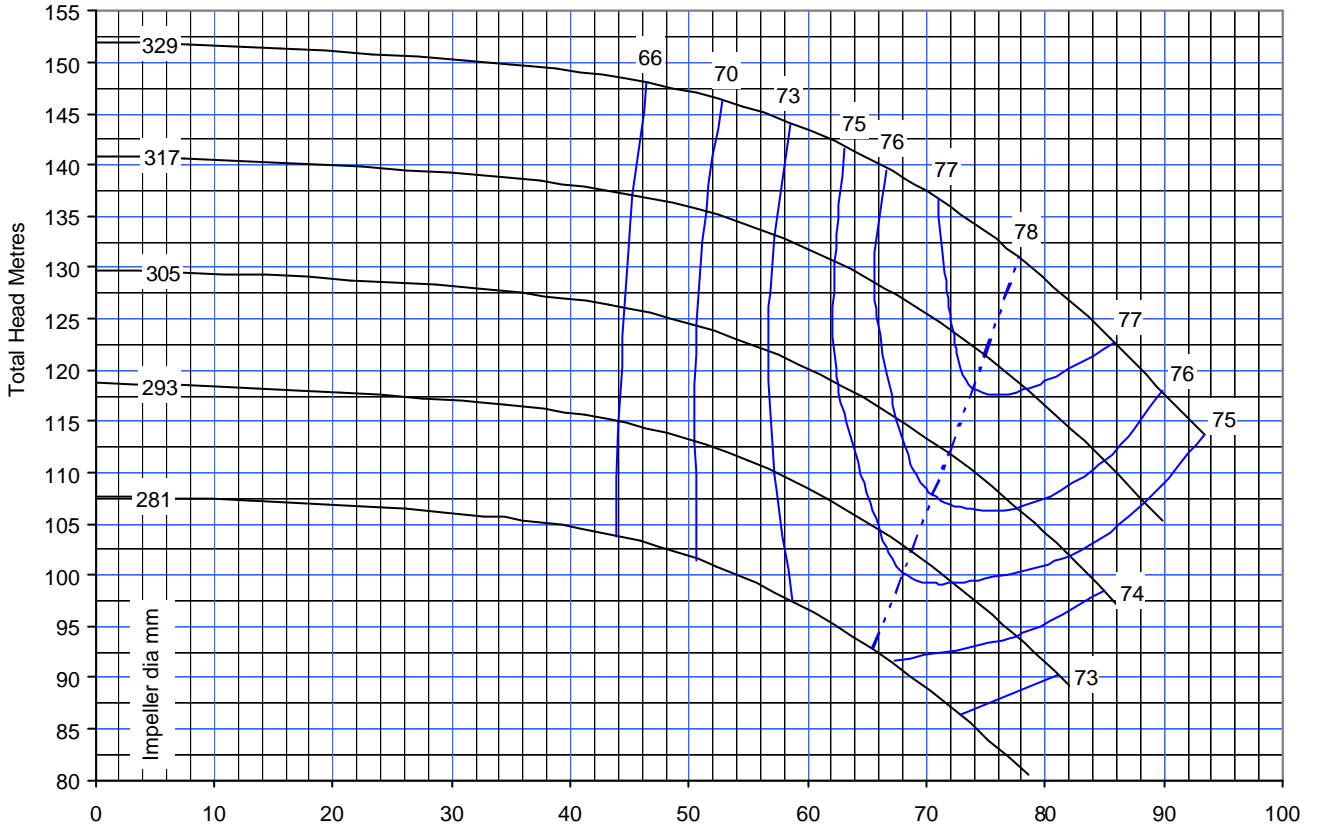
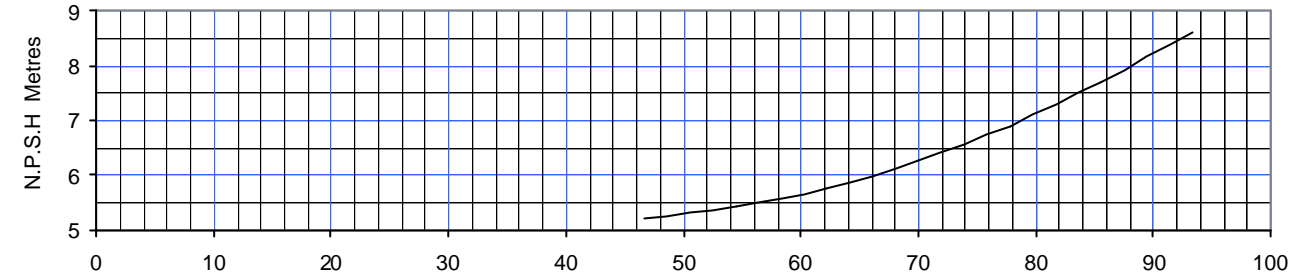

SUCTION DIA 125	DISCHARGE DIA 100	MAX PRESSURE 16 bar	PUMP MODEL TE 100-315	SPEED 2950
---------------------------	-----------------------------	-------------------------------	---------------------------------	----------------------

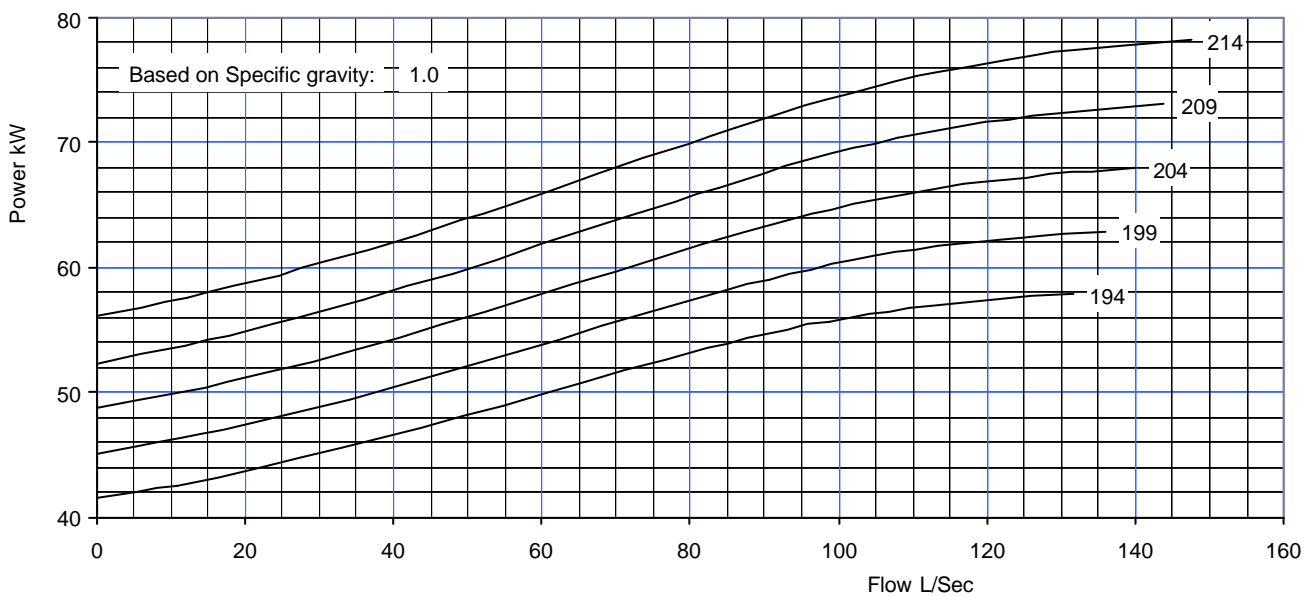
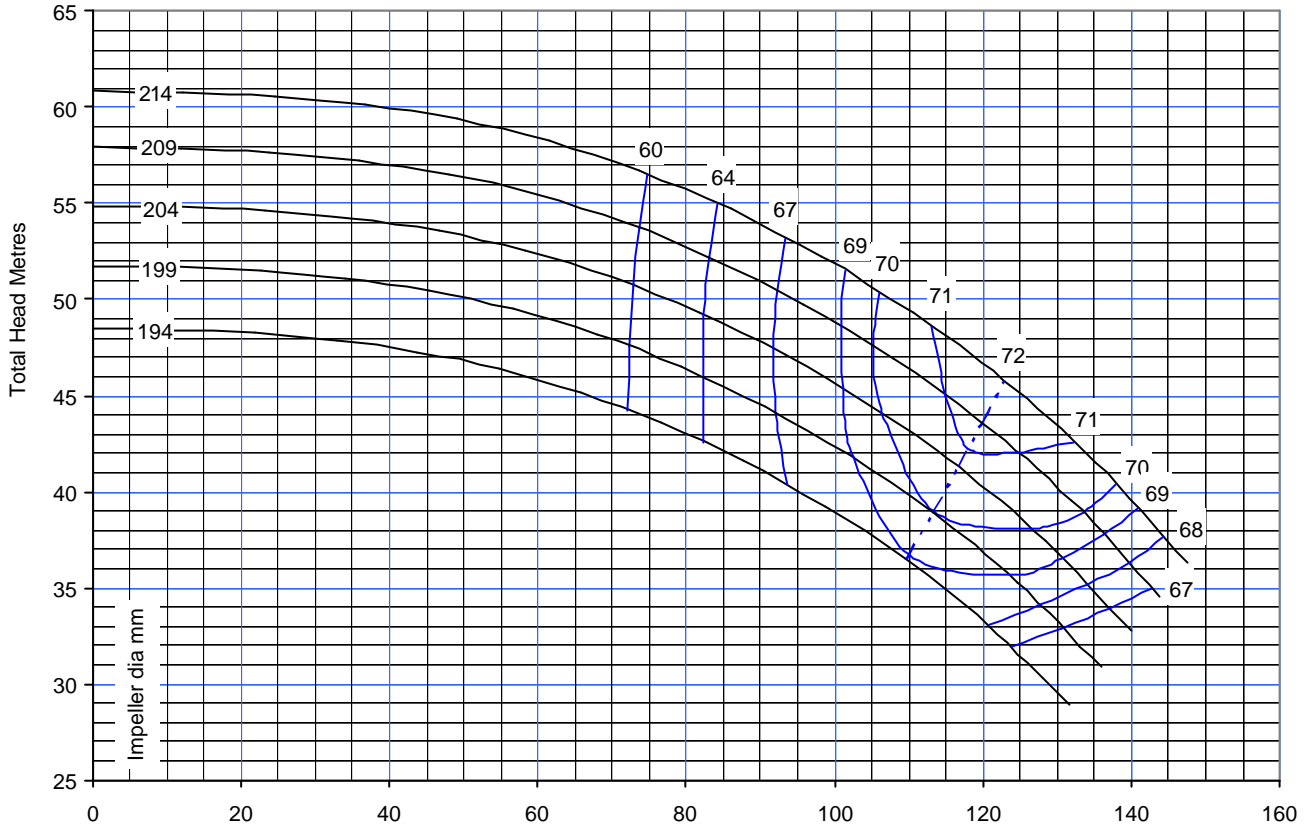
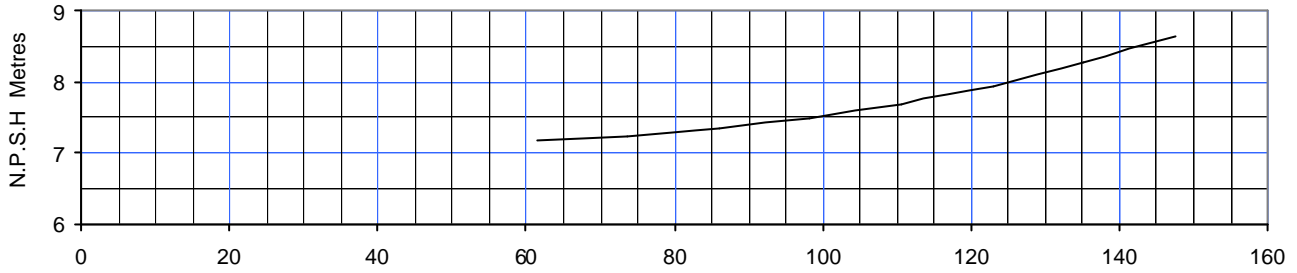

SUCTION DIA 150	DISCHARGE DIA 125	MAX PRESSURE 12 bar	PUMP MODEL TD 125-200	SPEED 2970
---------------------------	-----------------------------	-------------------------------	---------------------------------	----------------------

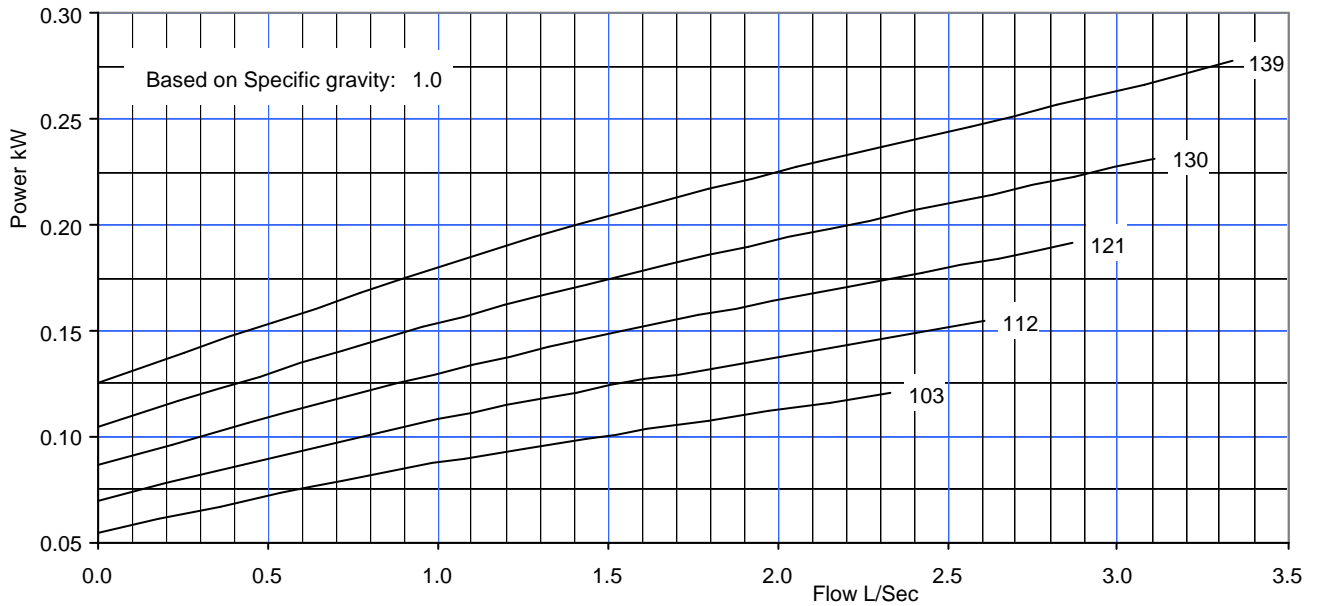
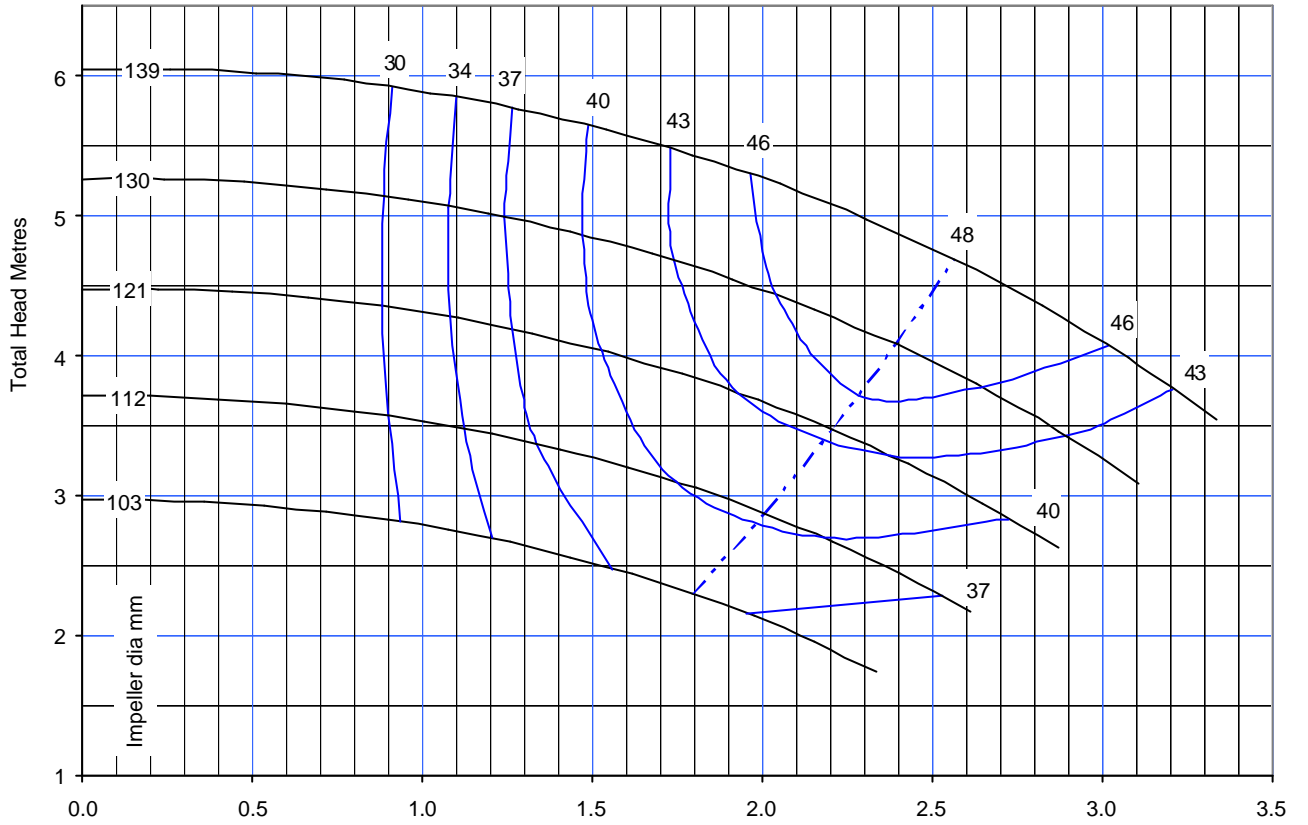
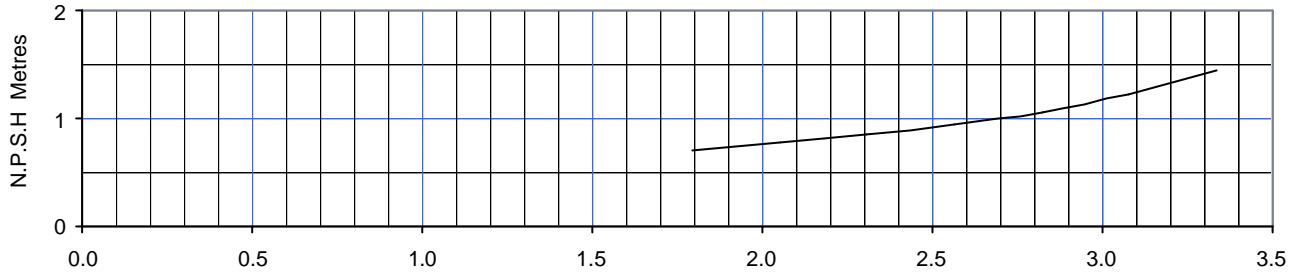

SUCTION DIA 50	DISCHARGE DIA 32	MAX PRESSURE 12 bar	PUMP MODEL TD 32-125	SPEED 1410
--------------------------	----------------------------	-------------------------------	--------------------------------	----------------------

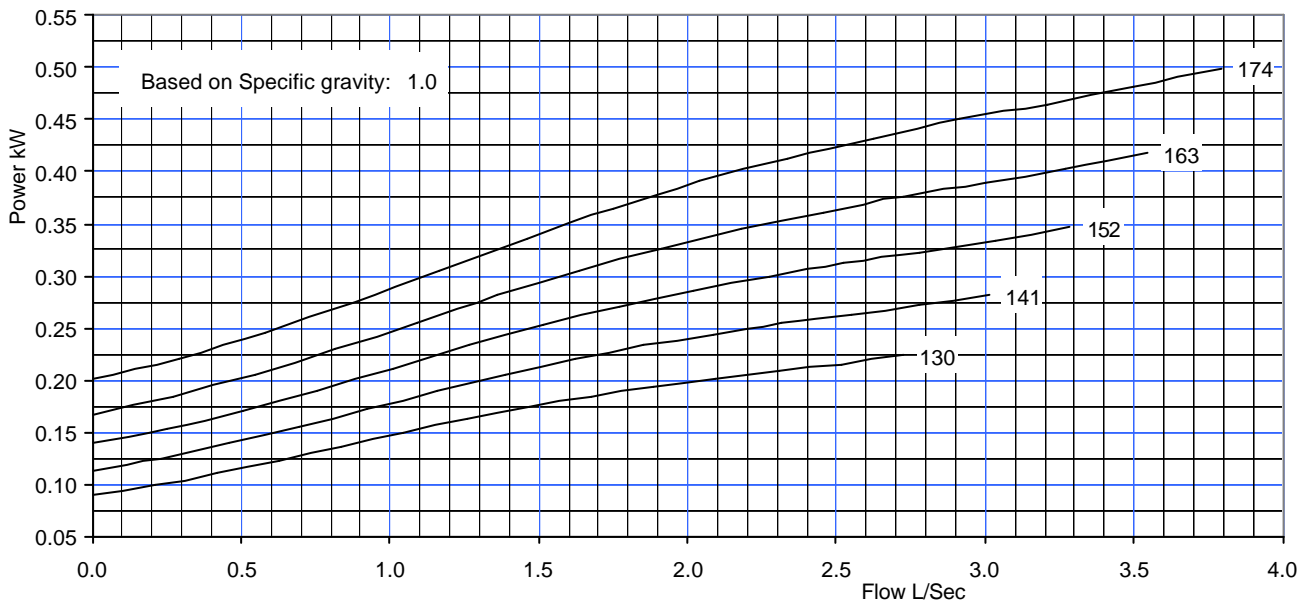
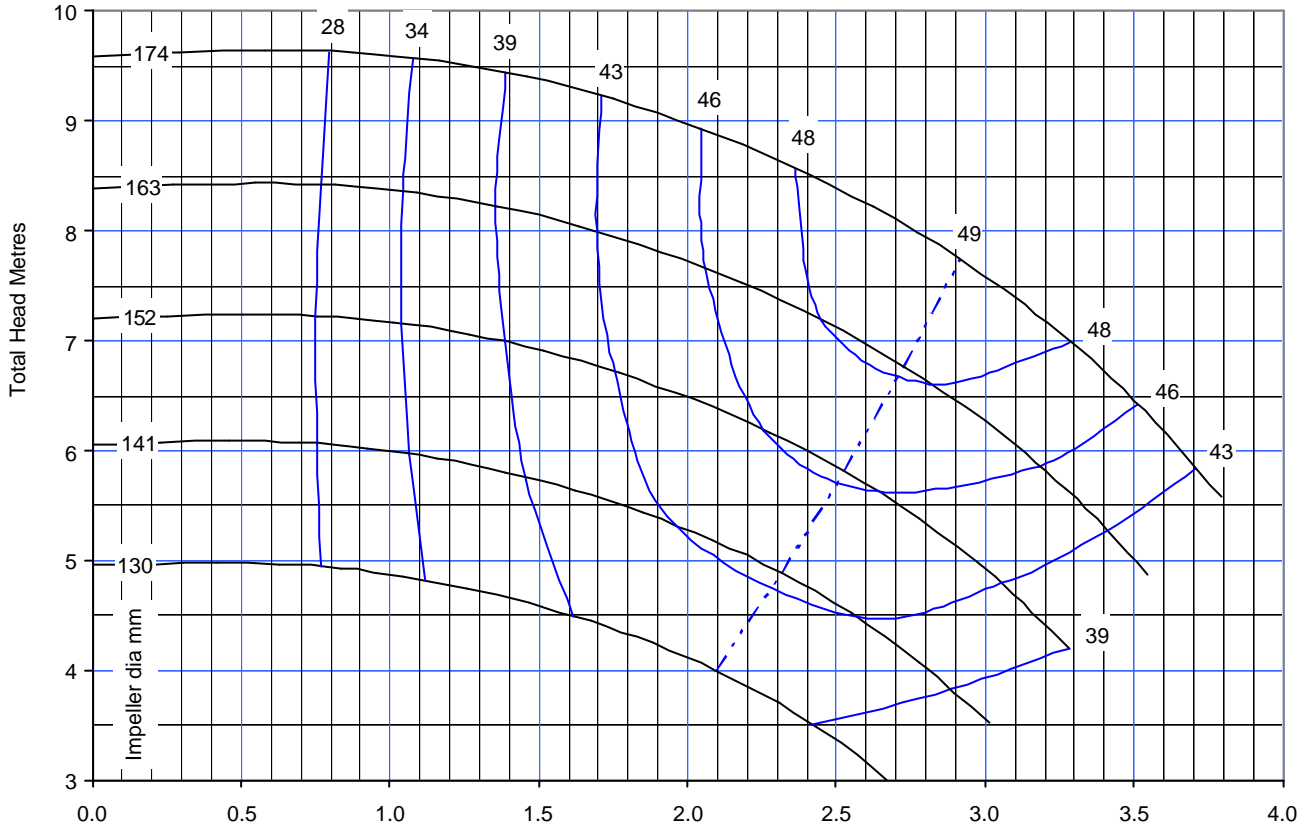
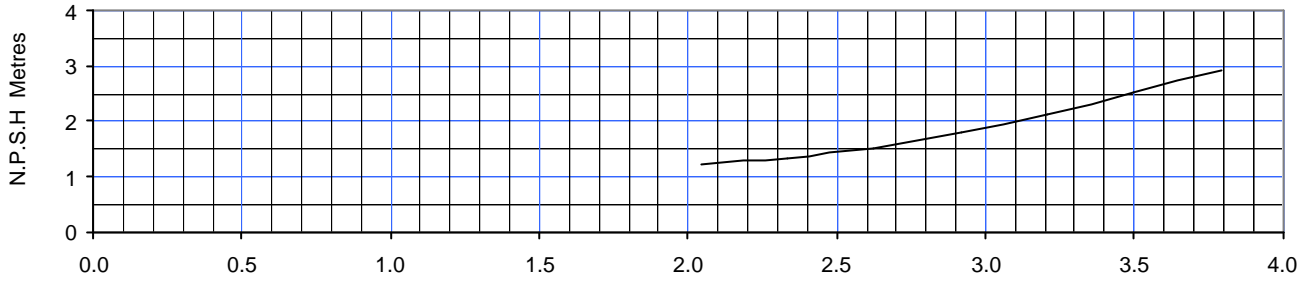

SUCTION DIA 50	DISCHARGE DIA 32	MAX PRESSURE 12 bar	PUMP MODEL TD 32-160	SPEED 1410
--------------------------	----------------------------	-------------------------------	--------------------------------	----------------------

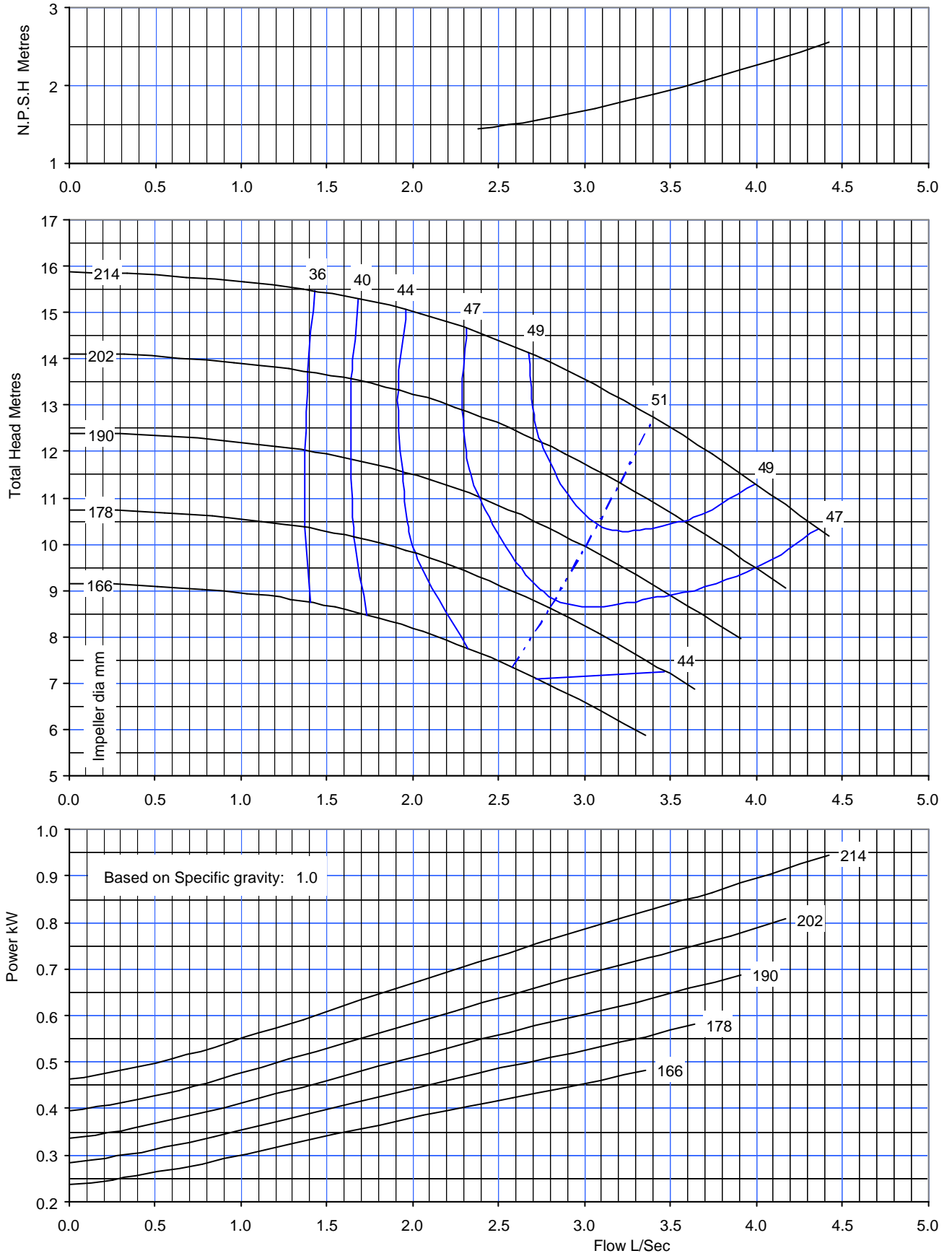

SUCTION DIA 50	DISCHARGE DIA 32	MAX PRESSURE 12 bar	PUMP MODEL TD 32-200	SPEED 1410
--------------------------	----------------------------	-------------------------------	--------------------------------	----------------------

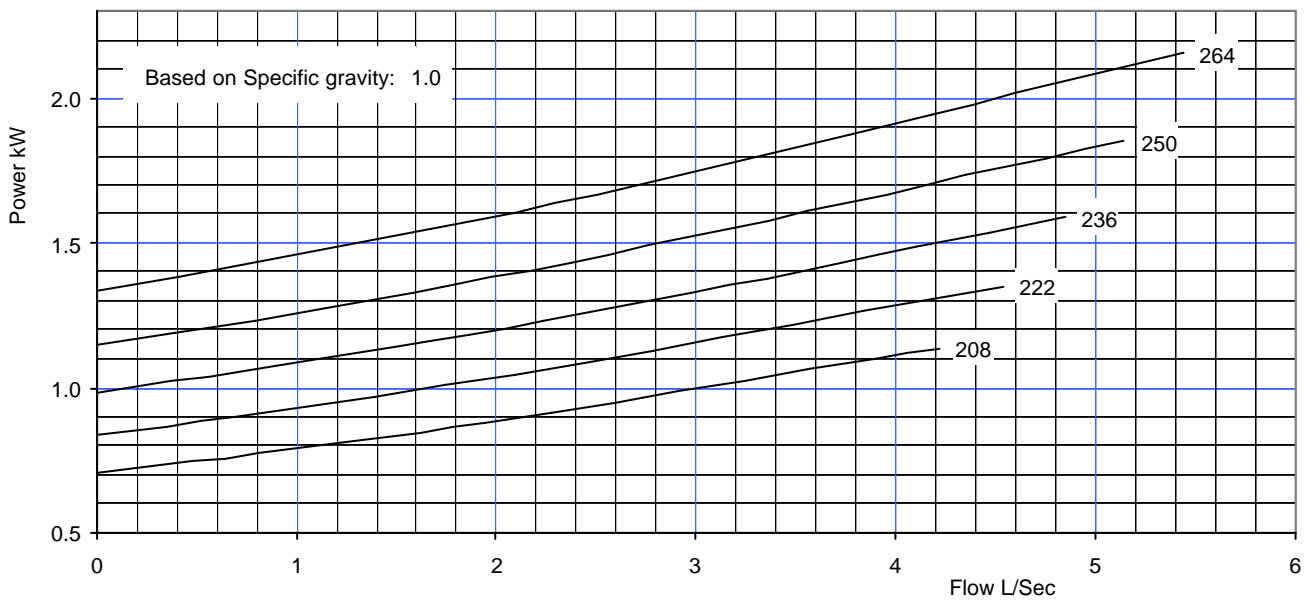
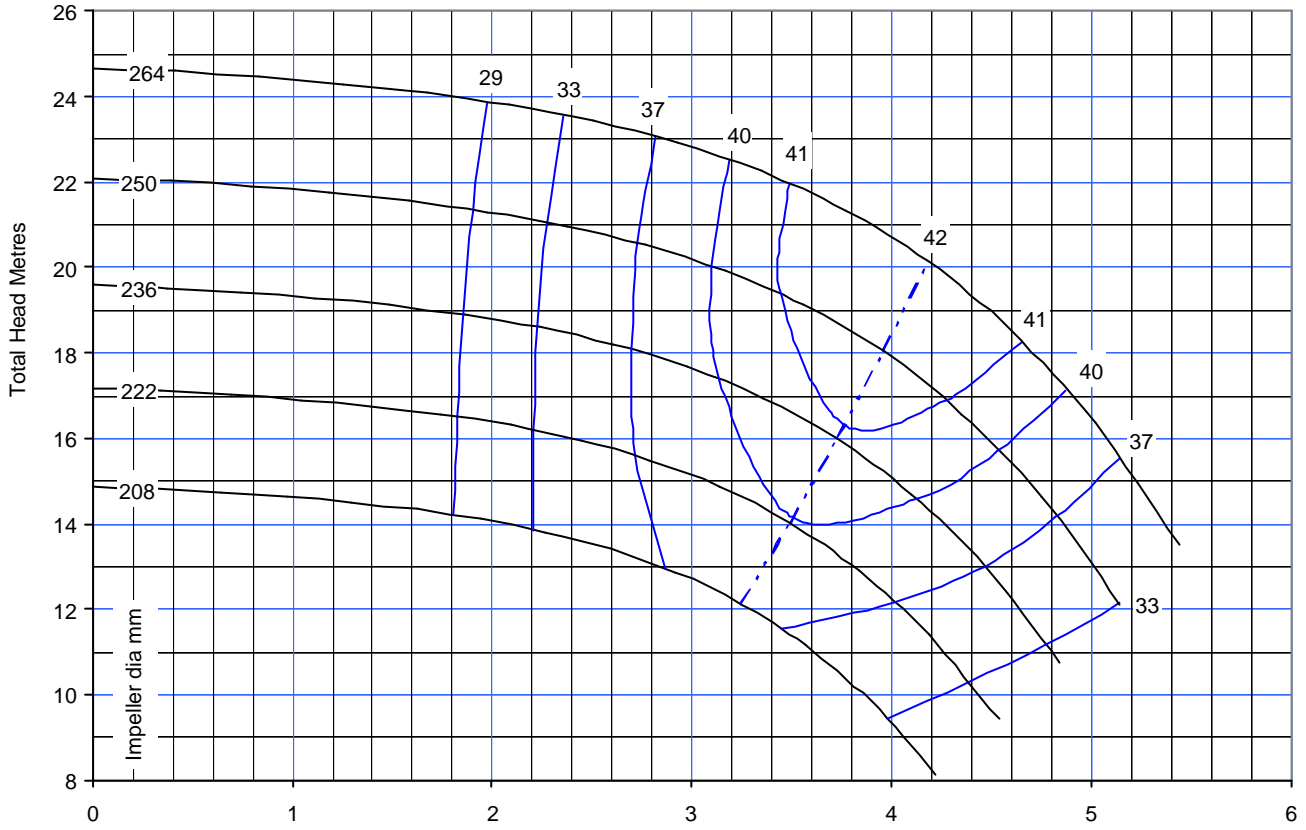
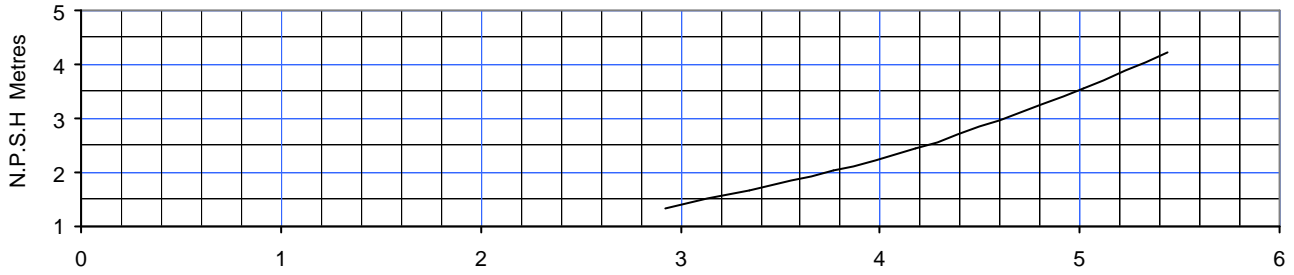

SUCTION DIA 50	DISCHARGE DIA 32	MAX PRESSURE 12 bar	PUMP MODEL TD 32-250	SPEED 1420
--------------------------	----------------------------	-------------------------------	--------------------------------	----------------------

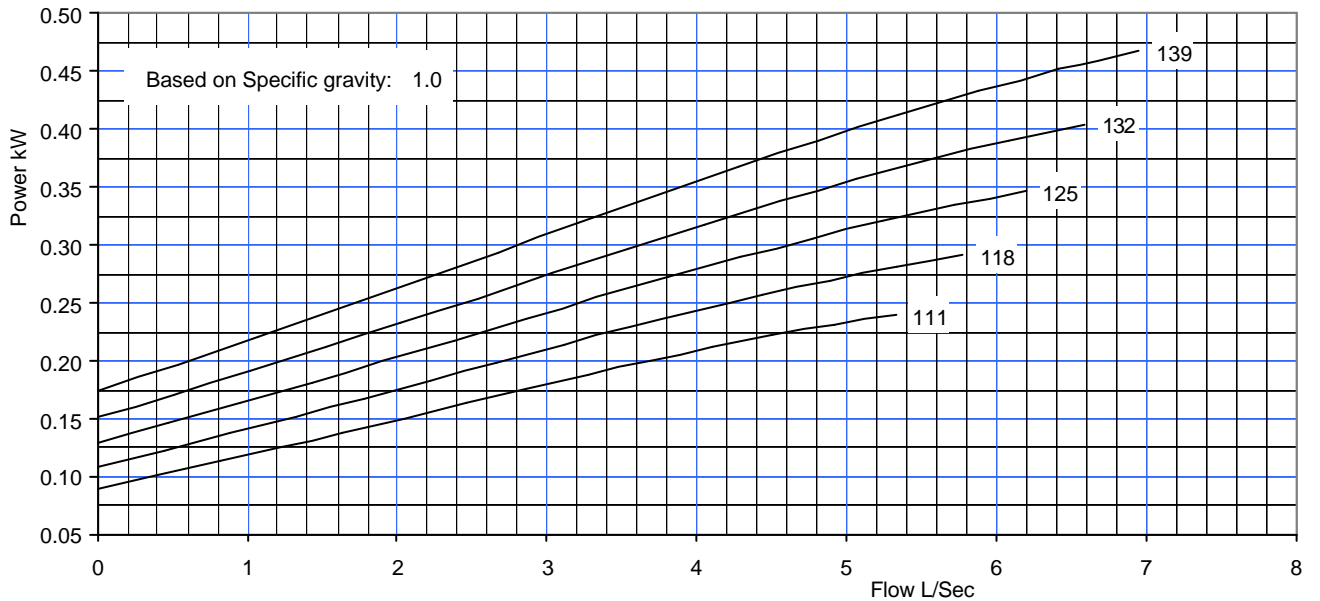
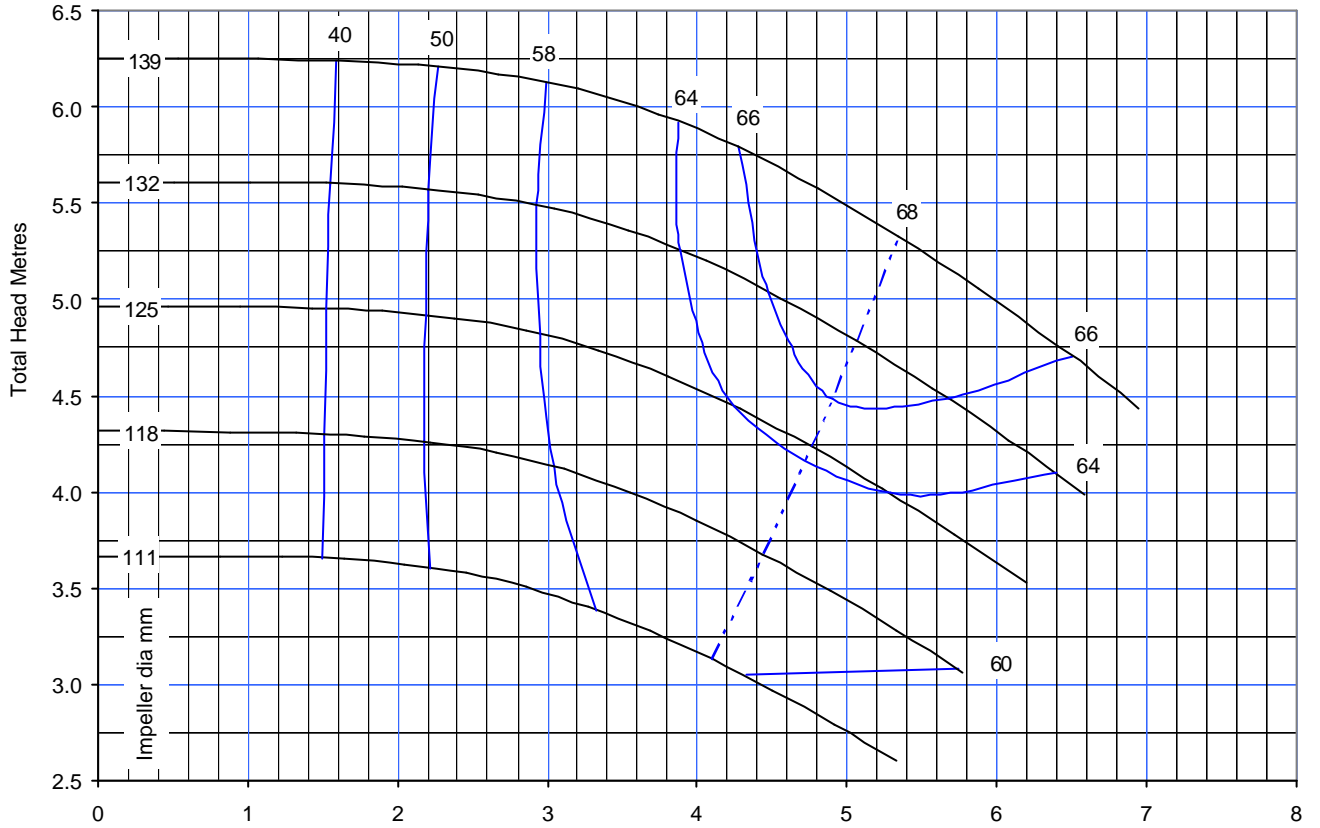
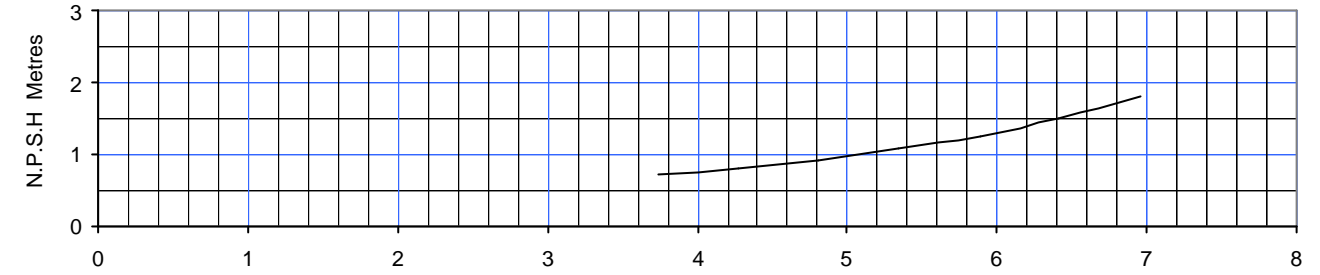

SUCTION DIA 65	DISCHARGE DIA 40	MAX PRESSURE 12 bar	PUMP MODEL TD 40-125	SPEED 1410
--------------------------	----------------------------	-------------------------------	--------------------------------	----------------------

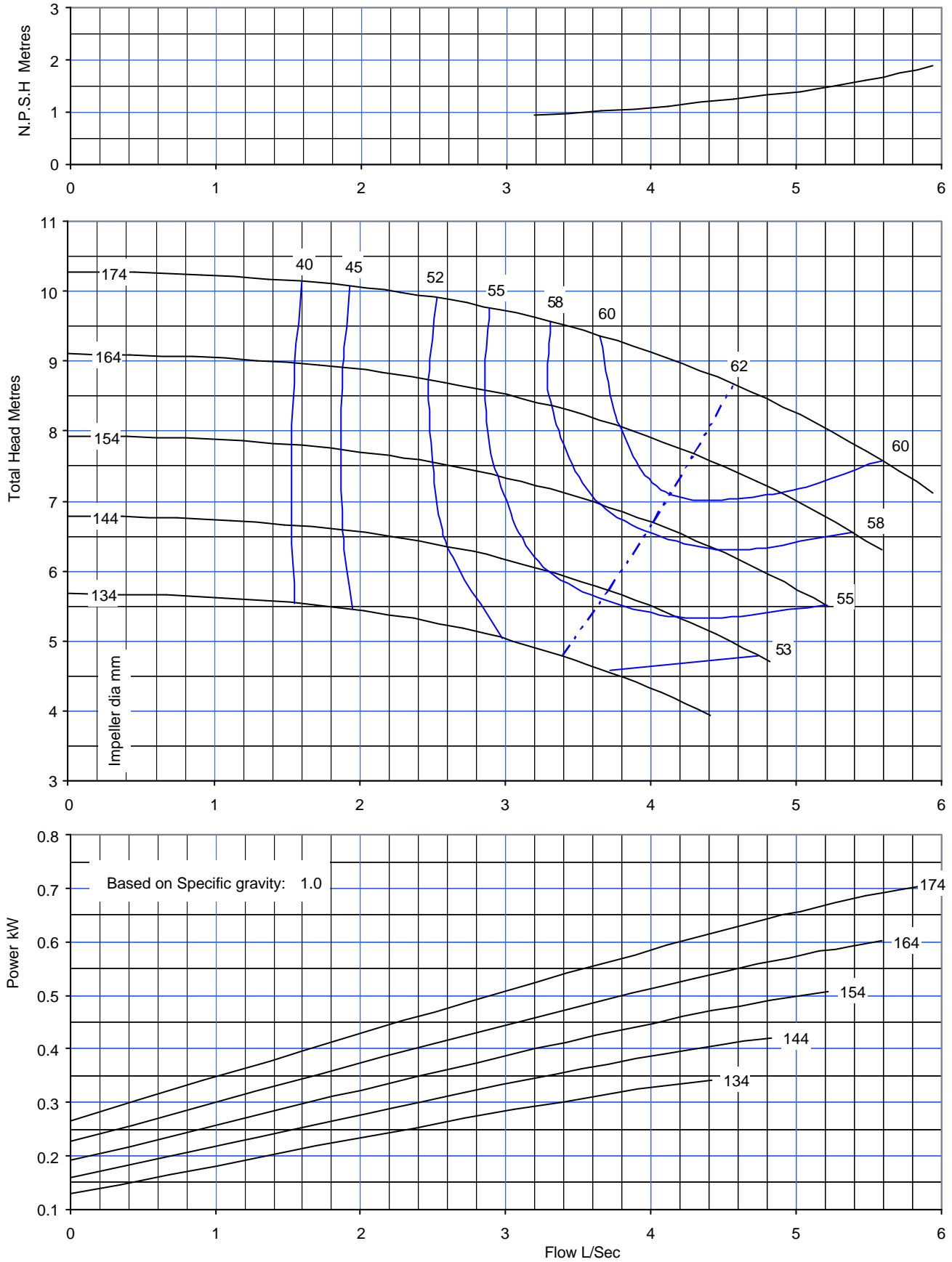

SUCTION DIA 65	DISCHARGE DIA 40	MAX PRESSURE 12 bar	PUMP MODEL TD 40-160	SPEED 1410
--------------------------	----------------------------	-------------------------------	--------------------------------	----------------------

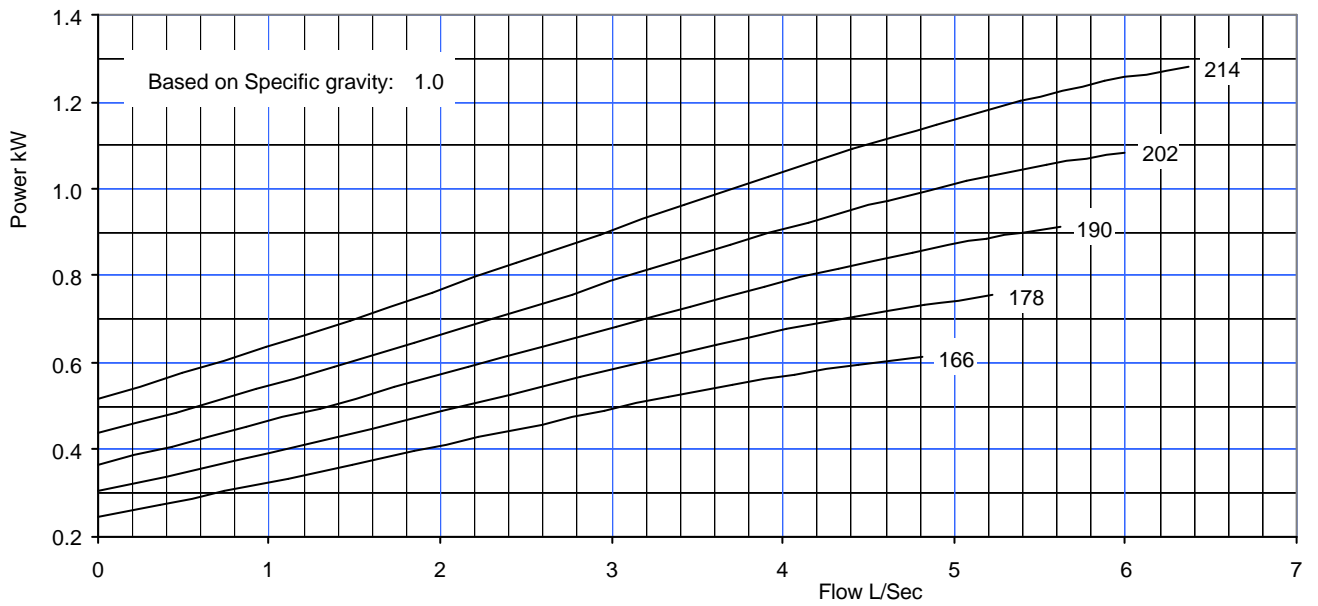
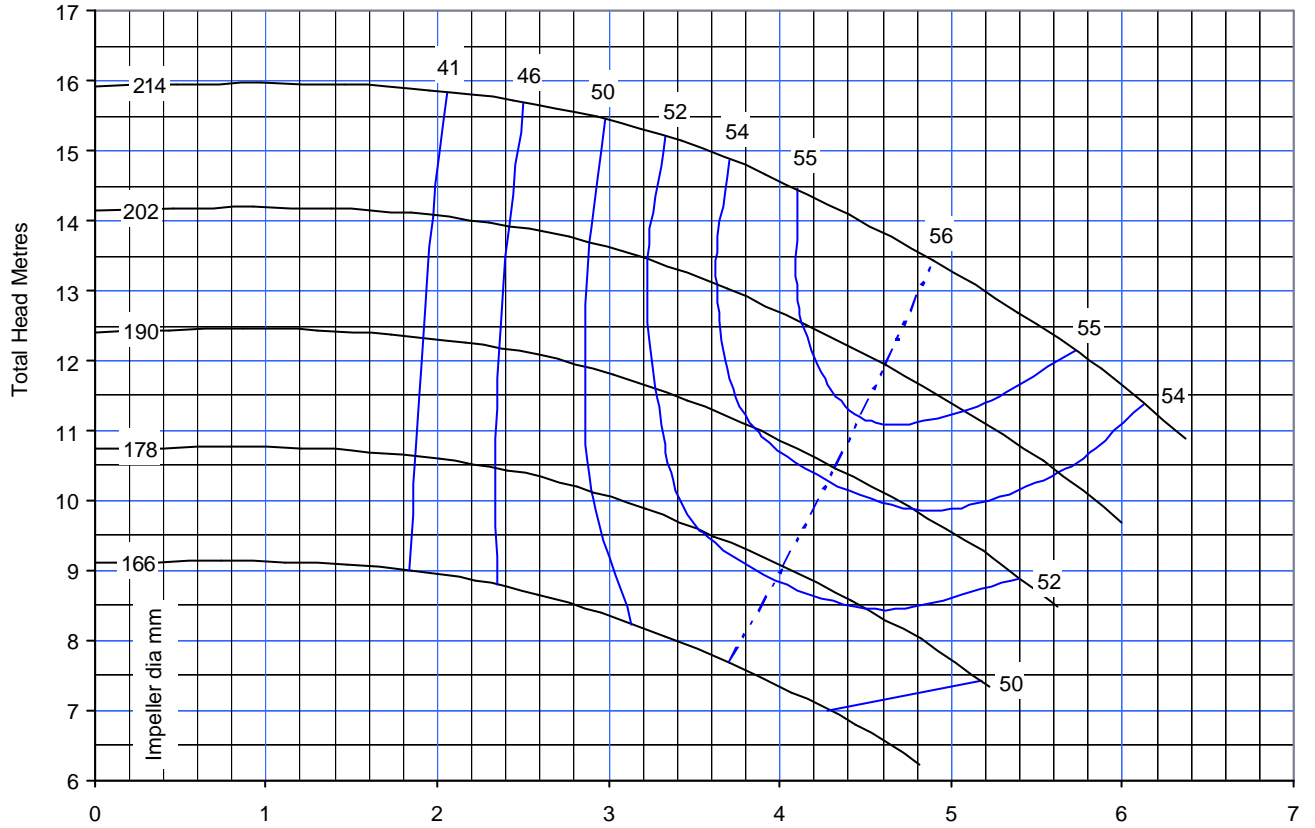
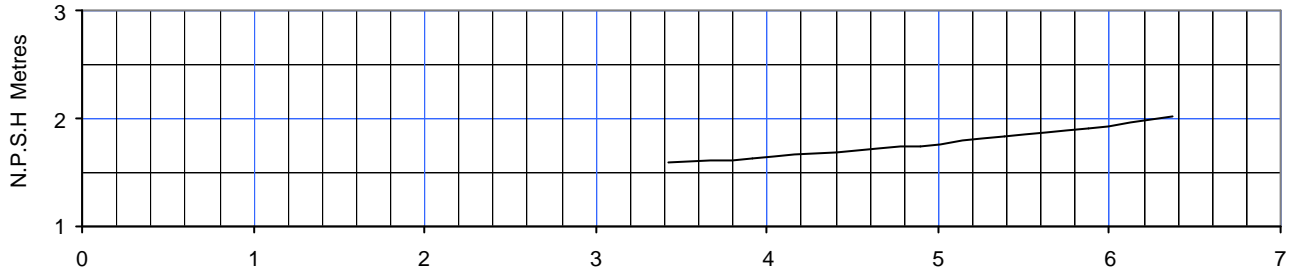

SUCTION DIA 65	DISCHARGE DIA 40	MAX PRESSURE 12 bar	PUMP MODEL TD 40-200	SPEED 1420
--------------------------	----------------------------	-------------------------------	--------------------------------	----------------------

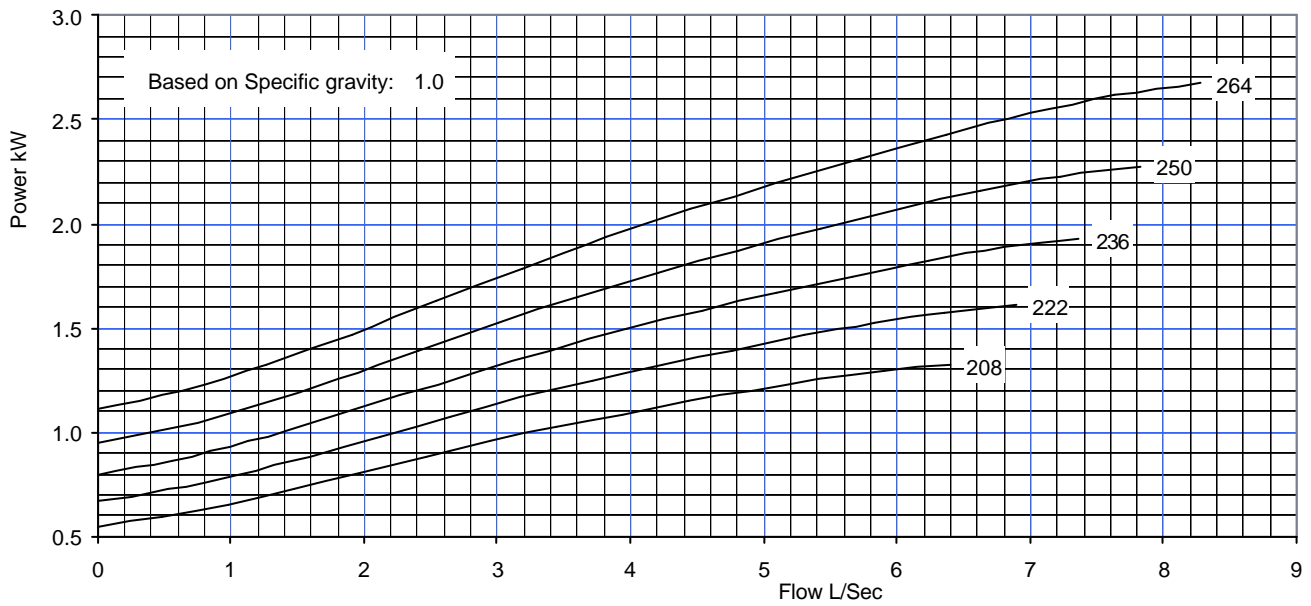
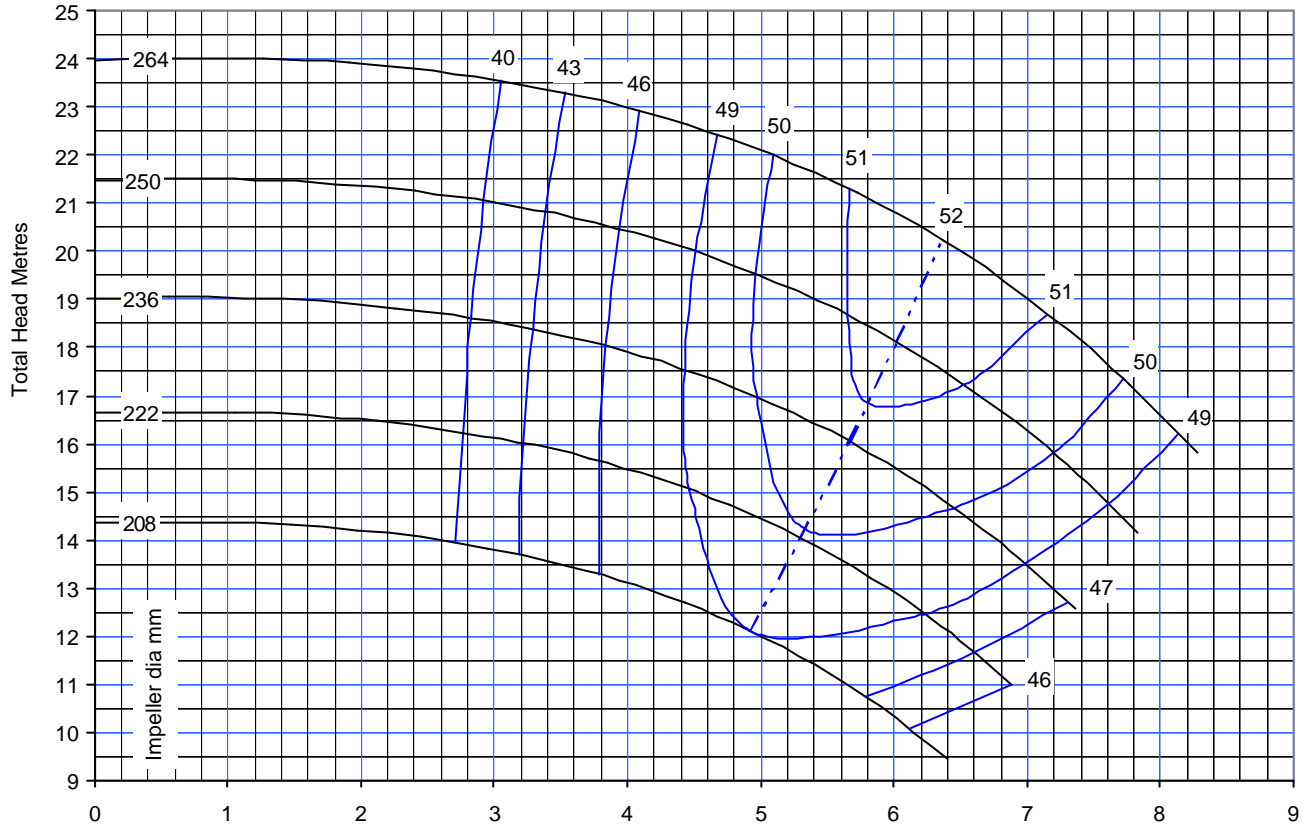
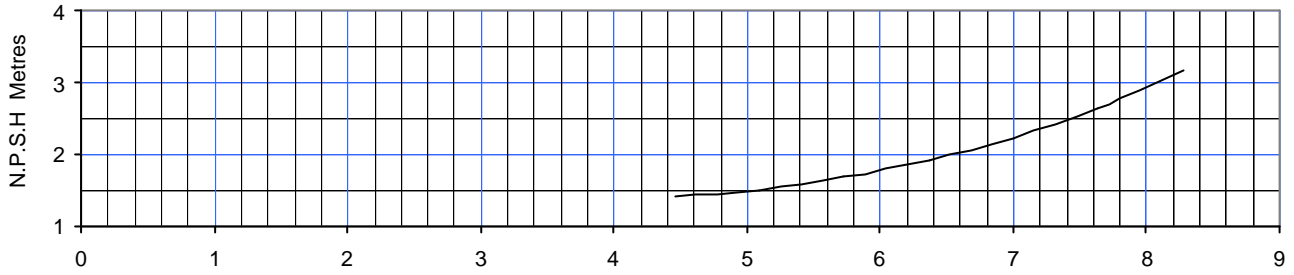

SUCTION DIA 65	DISCHARGE DIA 40	MAX PRESSURE 12 bar	PUMP MODEL TD 40-250	SPEED 1420
--------------------------	----------------------------	-------------------------------	--------------------------------	----------------------

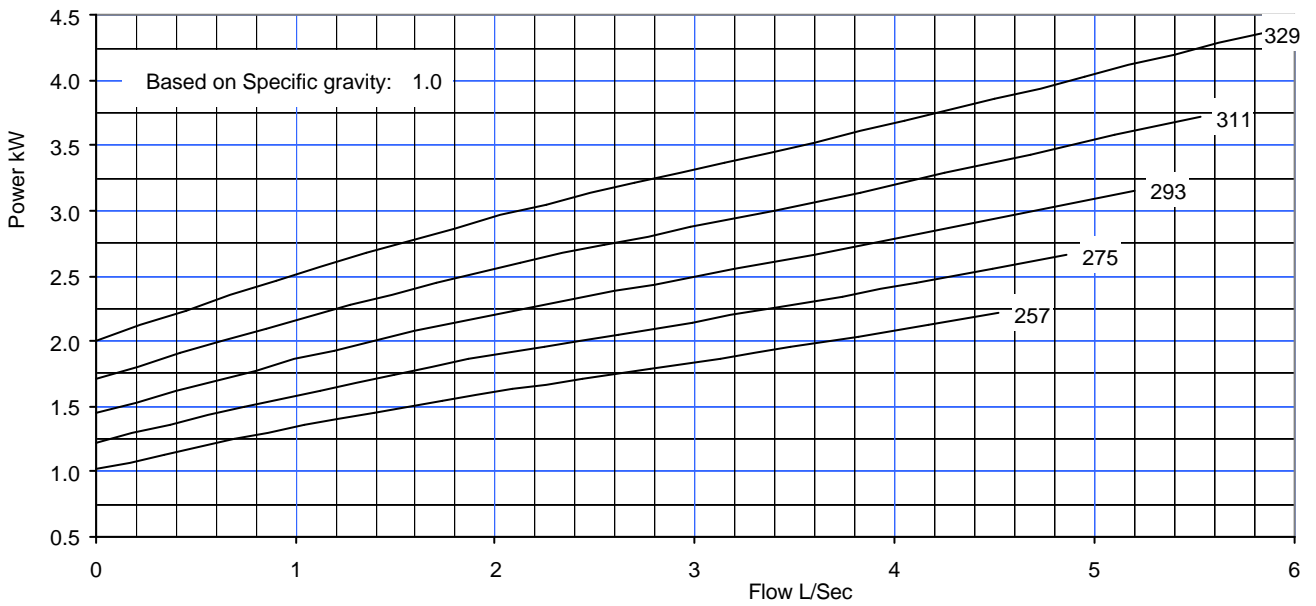
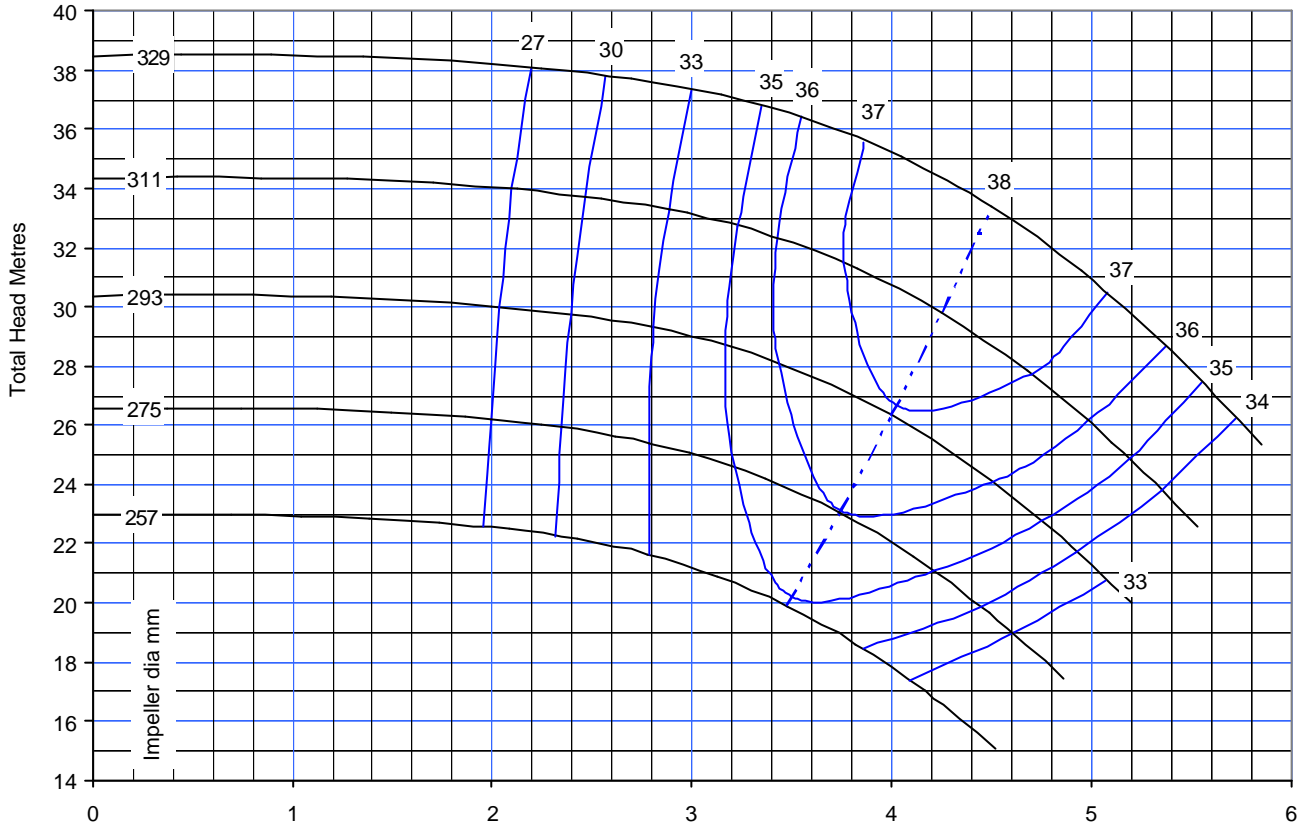
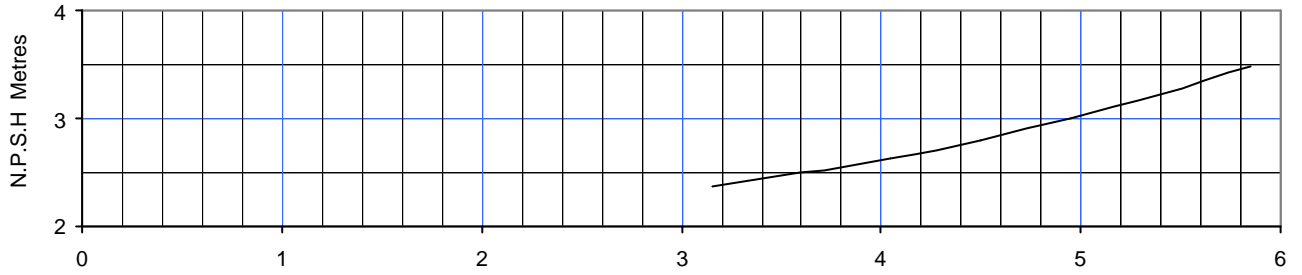

SUCTION DIA 65	DISCHARGE DIA 40	MAX PRESSURE 12 bar	PUMP MODEL TD 40-315	SPEED 1450
--------------------------	----------------------------	-------------------------------	--------------------------------	----------------------

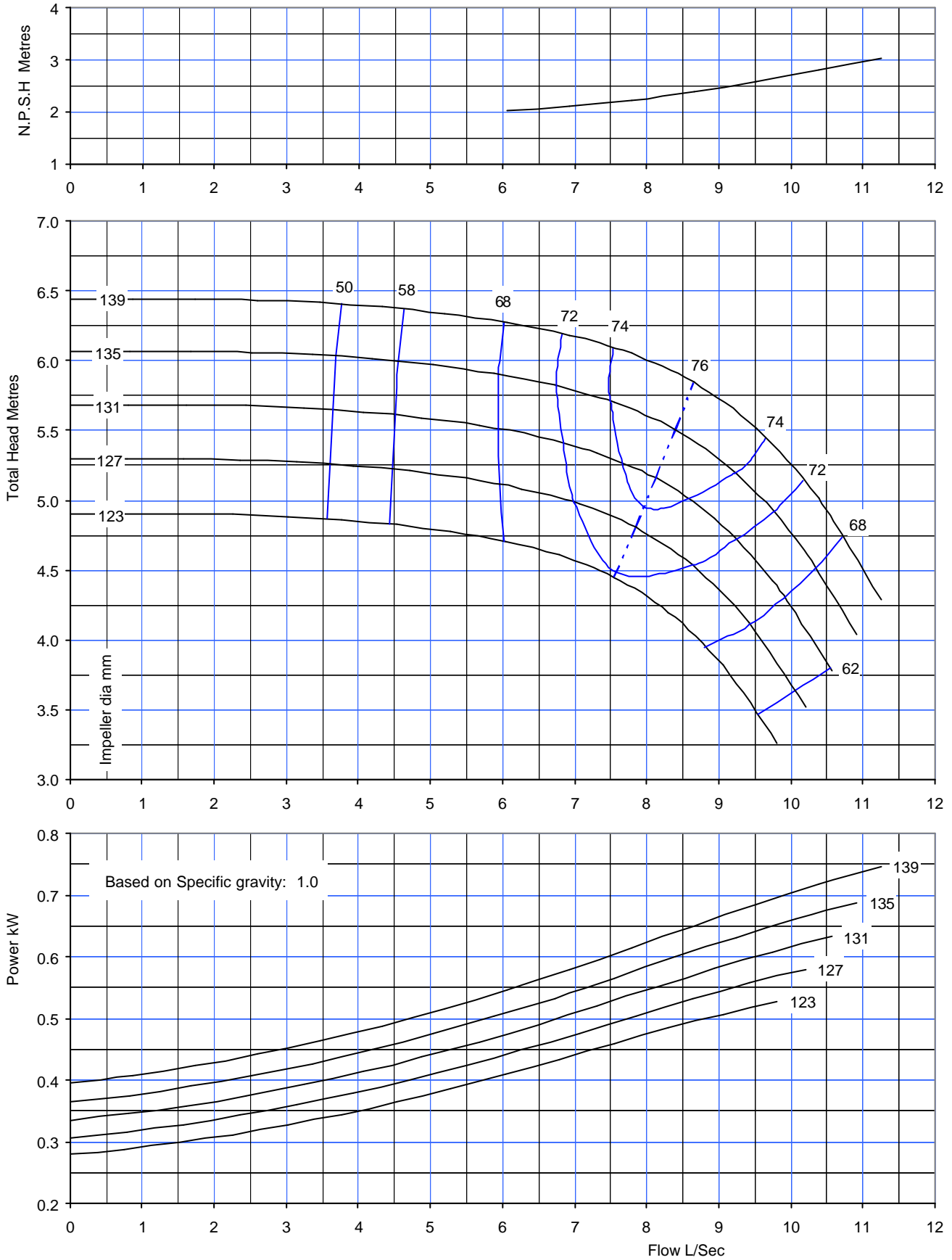

SUCTION DIA 65	DISCHARGE DIA 50	MAX PRESSURE 12 bar	PUMP MODEL TD 50-125	SPEED 1410
--------------------------	----------------------------	-------------------------------	--------------------------------	----------------------

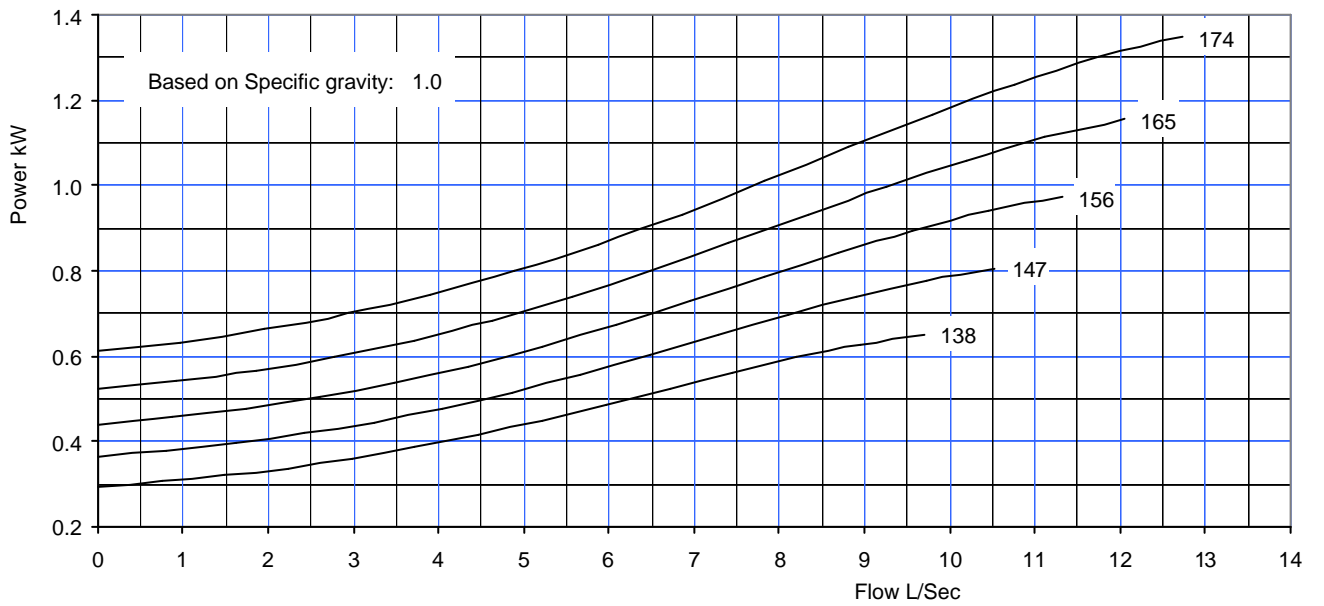
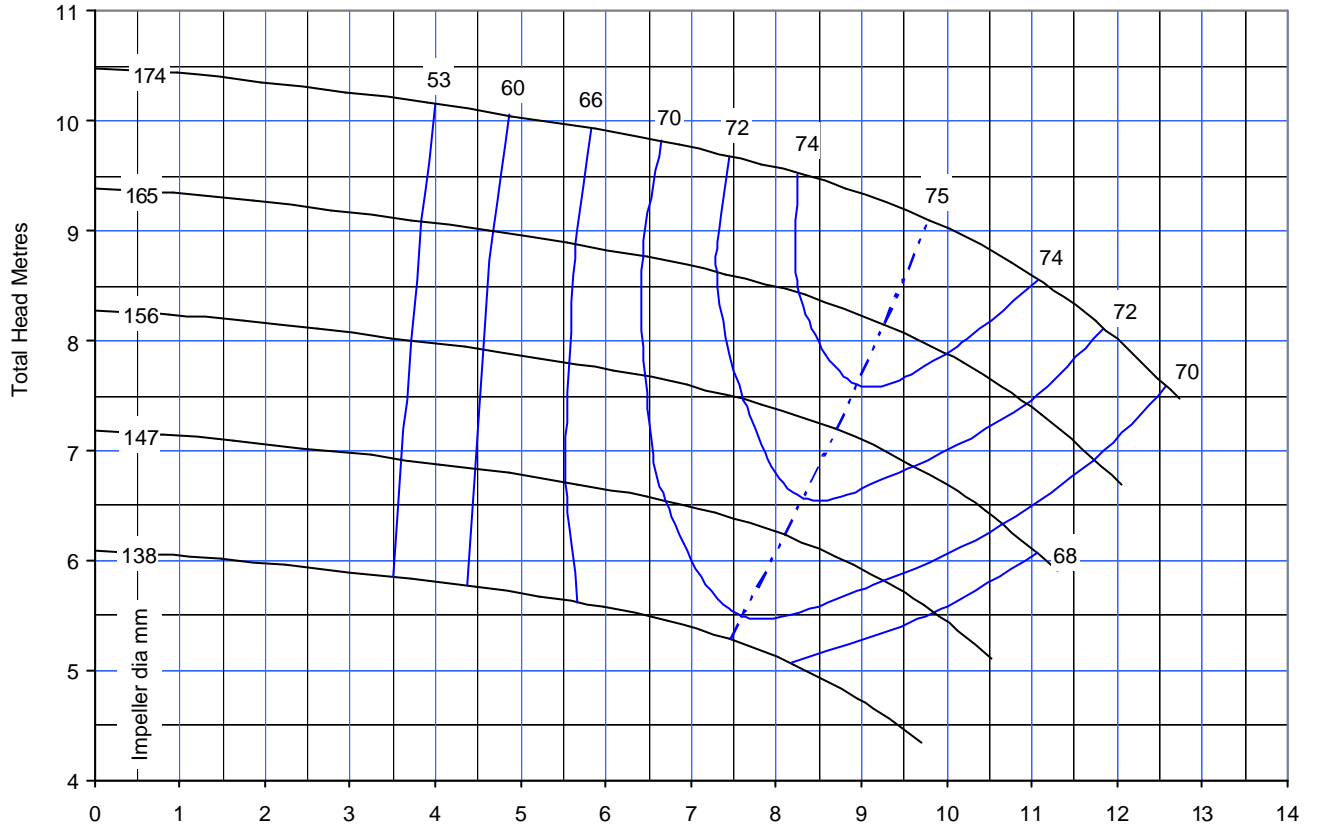
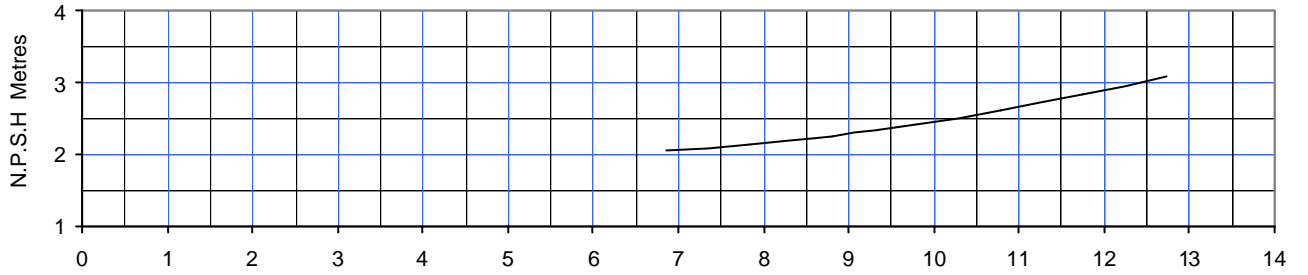

SUCTION DIA 65	DISCHARGE DIA 50	MAX PRESSURE 12 bar	PUMP MODEL TD 50-160	SPEED 1420
--------------------------	----------------------------	-------------------------------	--------------------------------	----------------------

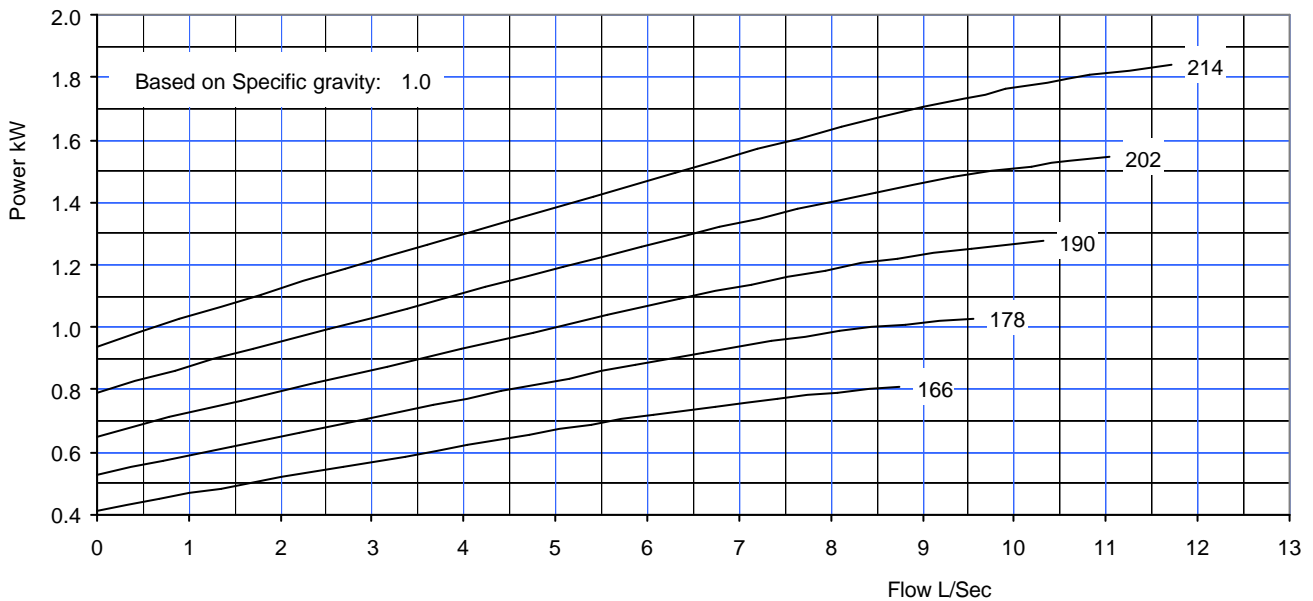
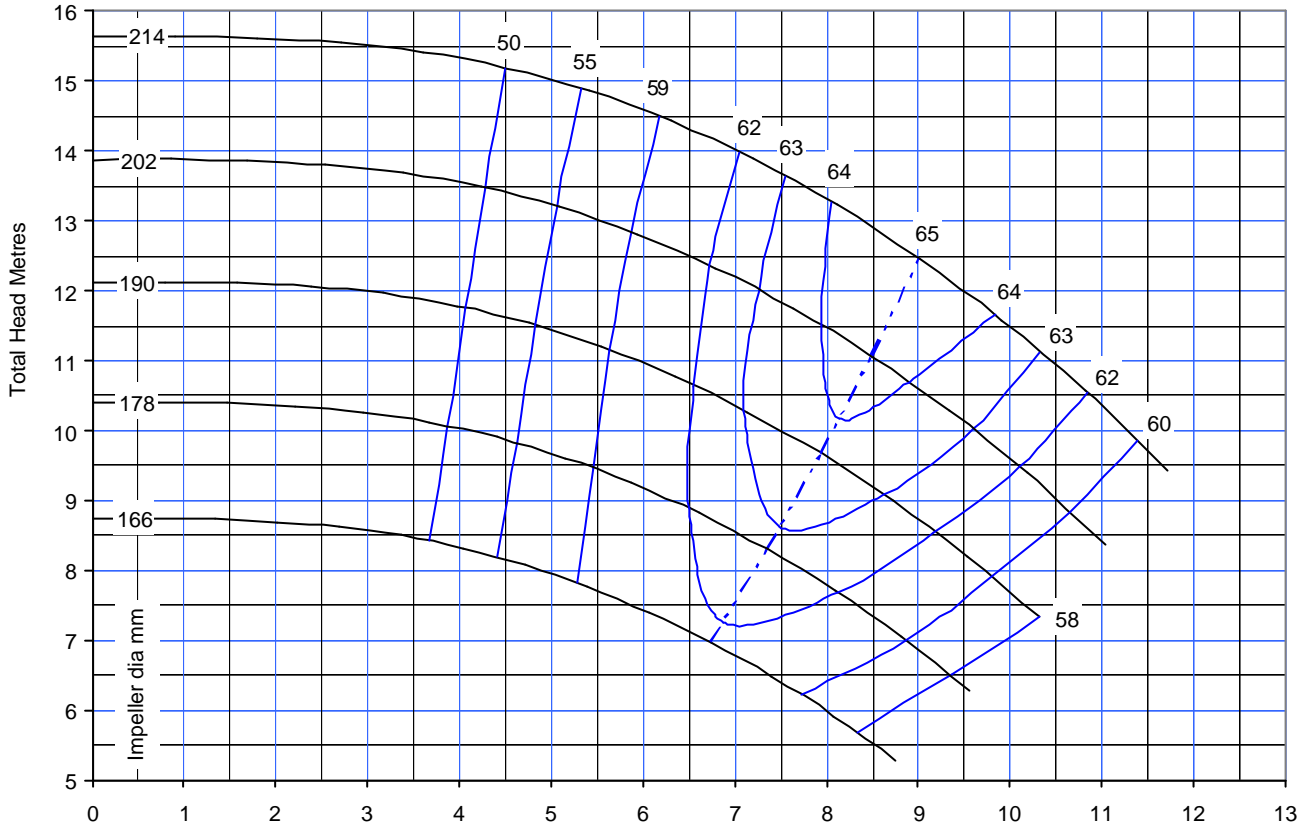
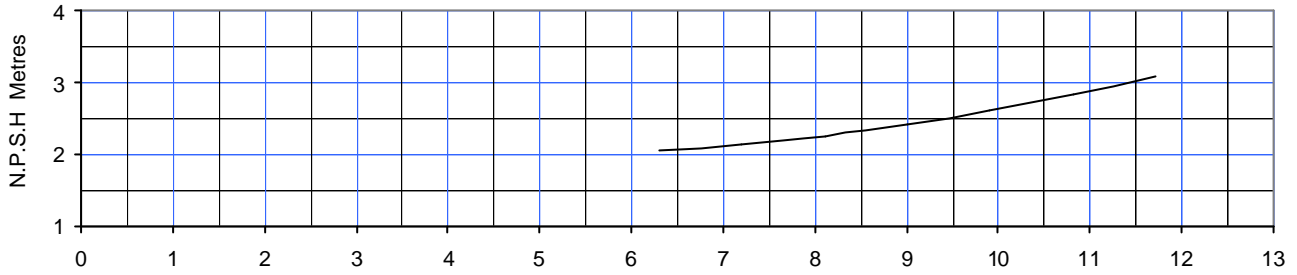

SUCTION DIA 65	DISCHARGE DIA 50	MAX PRESSURE 12 bar	PUMP MODEL TD 50-200	SPEED 1420
--------------------------	----------------------------	-------------------------------	--------------------------------	----------------------

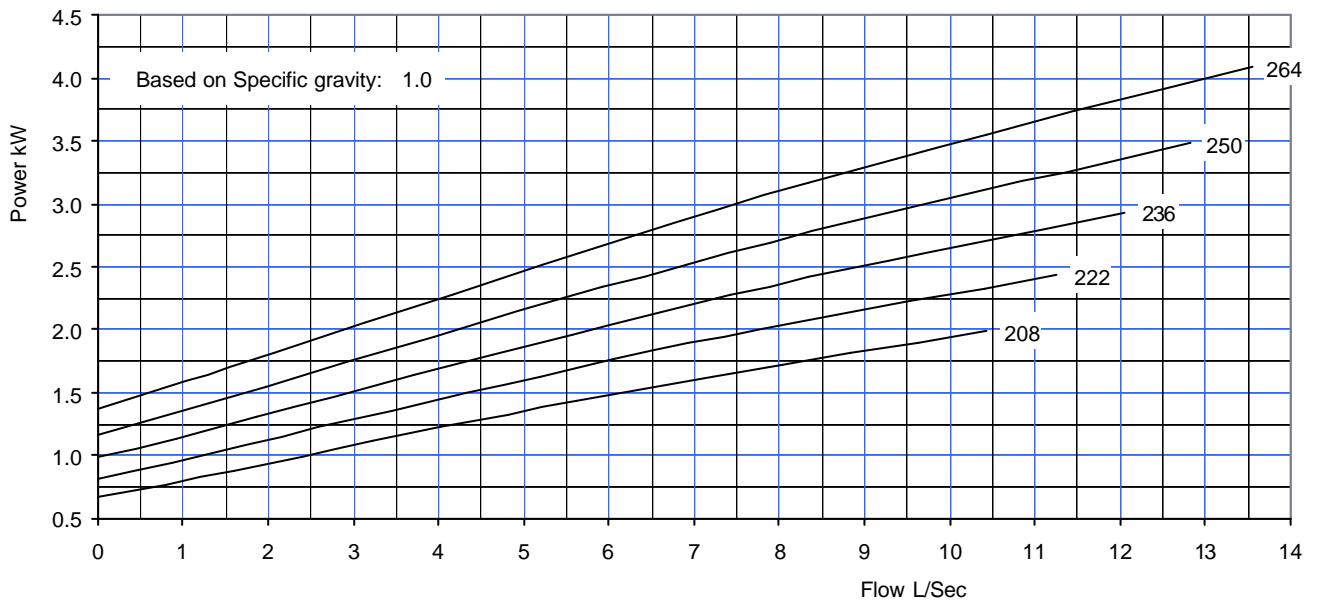
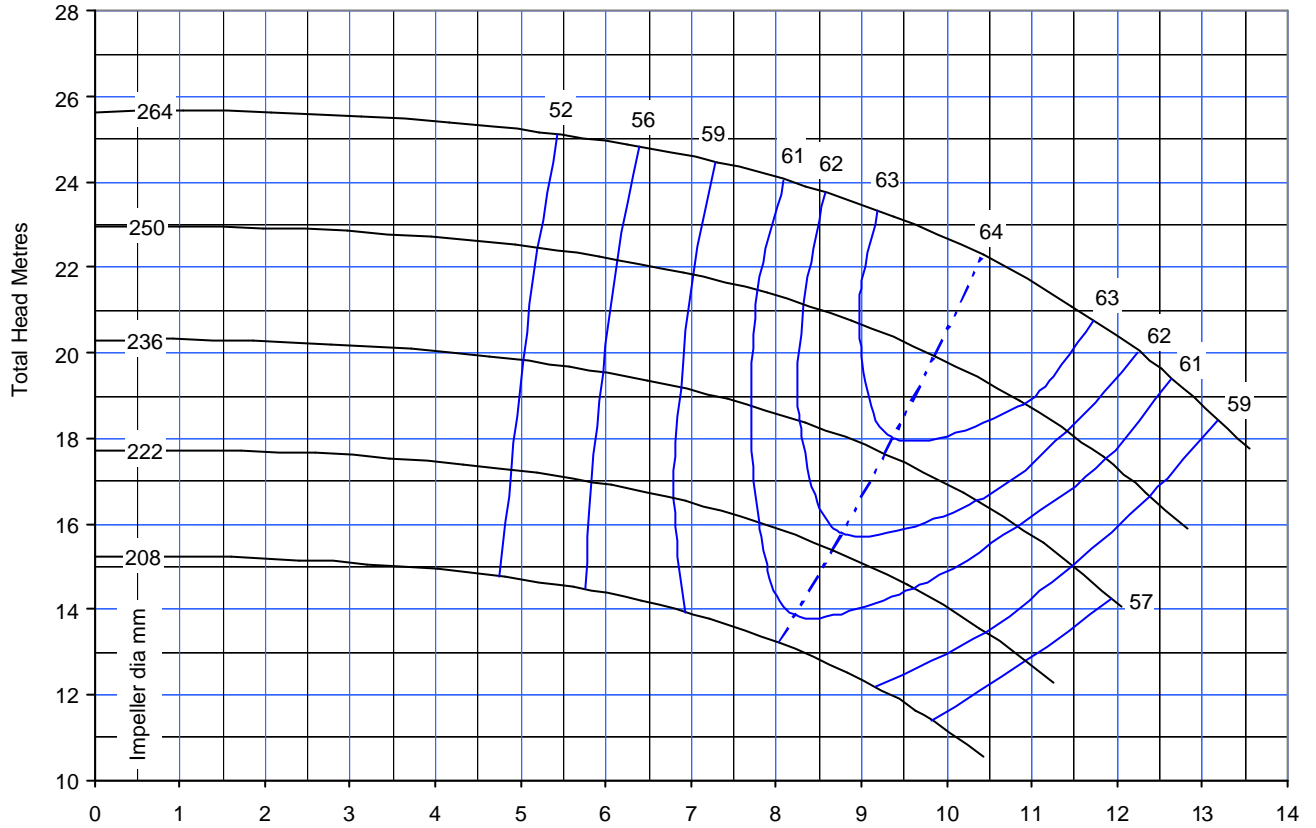
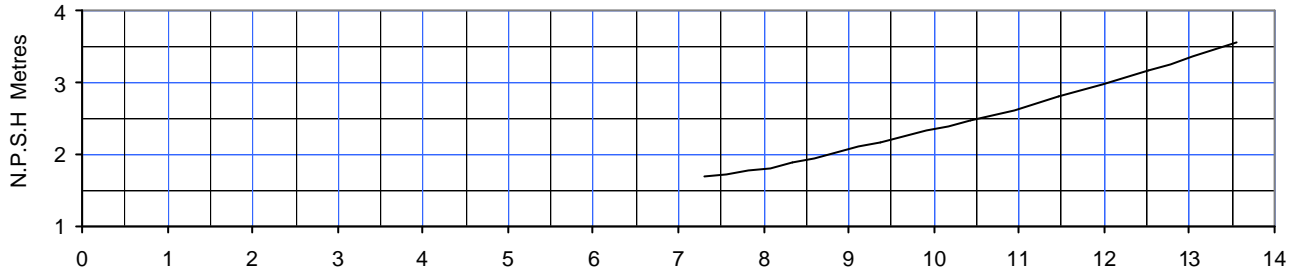

SUCTION DIA 65	DISCHARGE DIA 50	MAX PRESSURE 12 bar	PUMP MODEL TD 50-250	SPEED 1440
--------------------------	----------------------------	-------------------------------	--------------------------------	----------------------

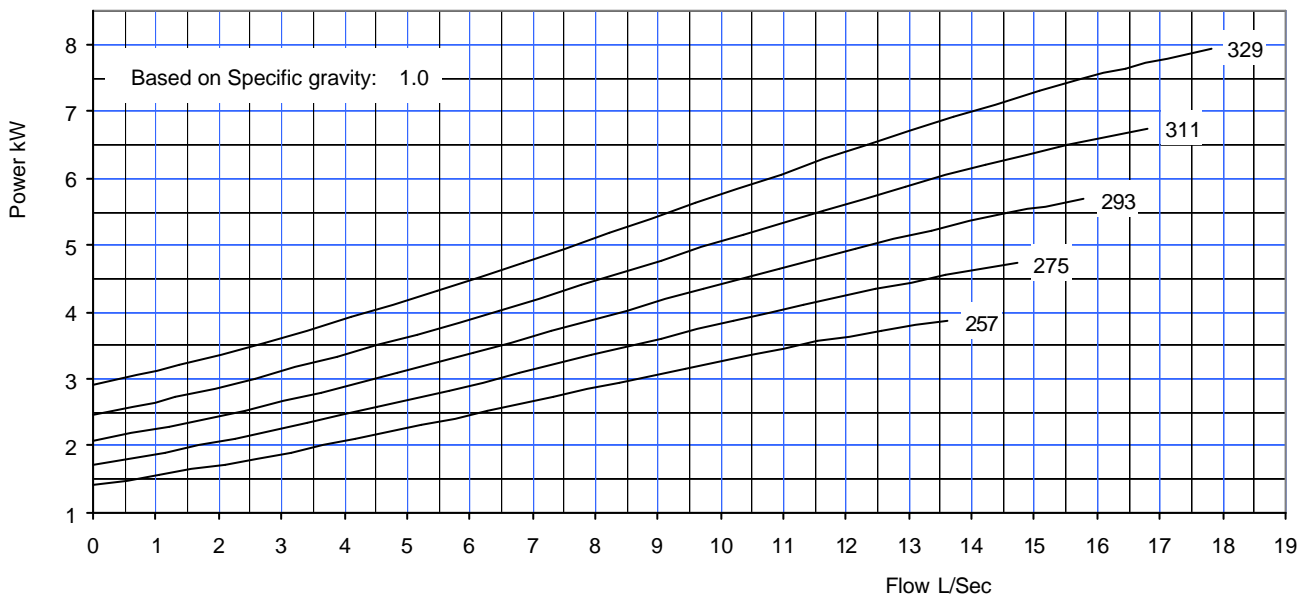
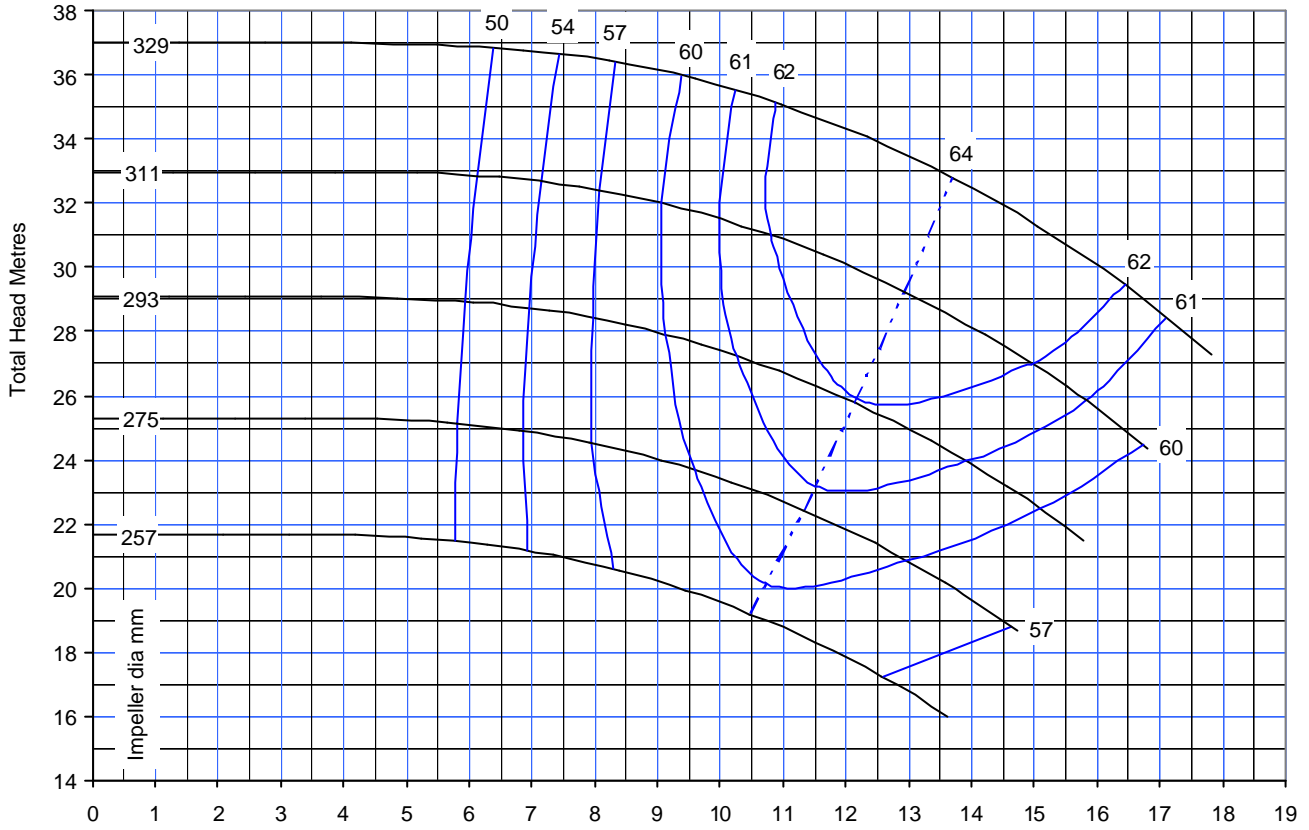
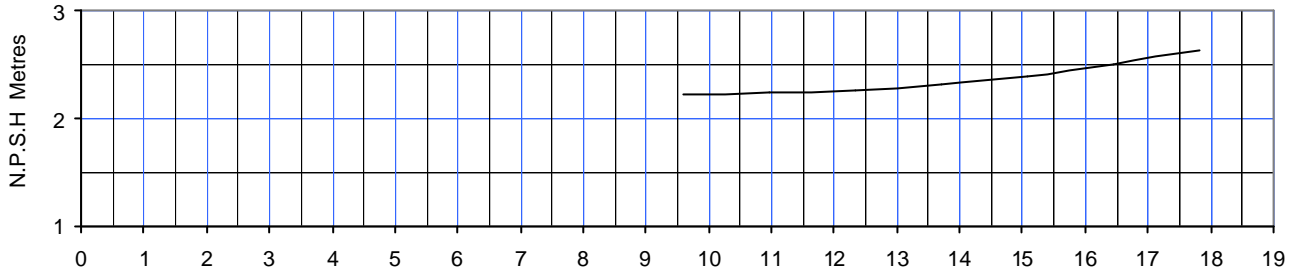

SUCTION DIA 65	DISCHARGE DIA 50	MAX PRESSURE 12 bar	PUMP MODEL TD 50-315	SPEED 1450
--------------------------	----------------------------	-------------------------------	--------------------------------	----------------------

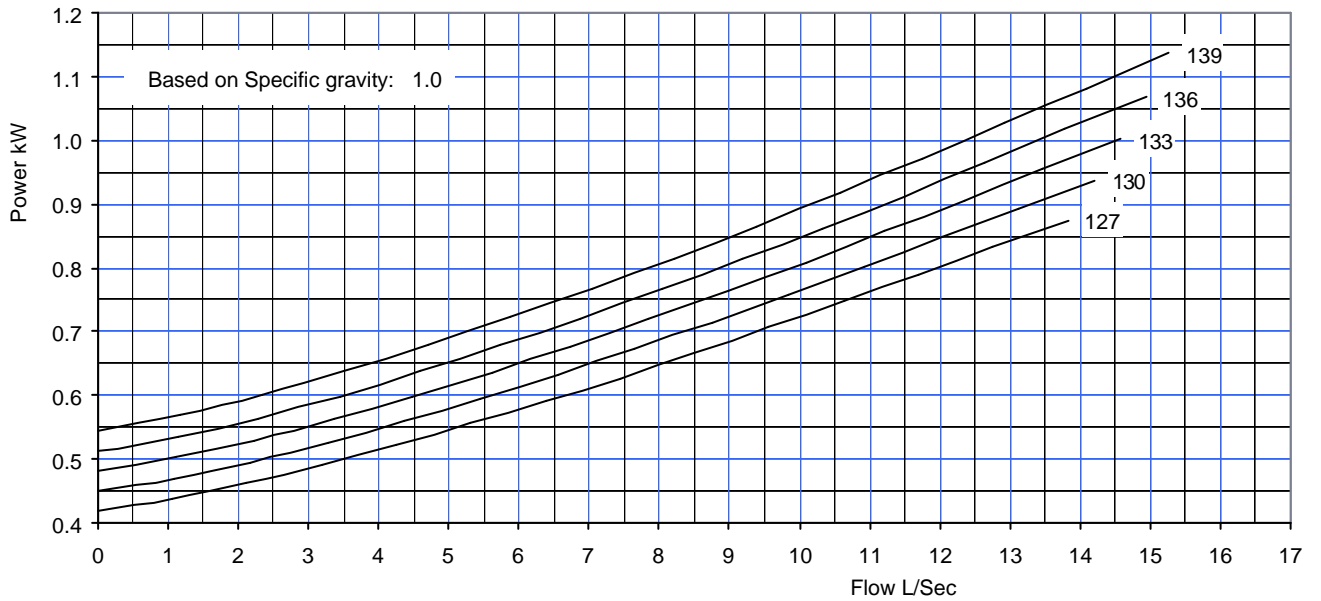
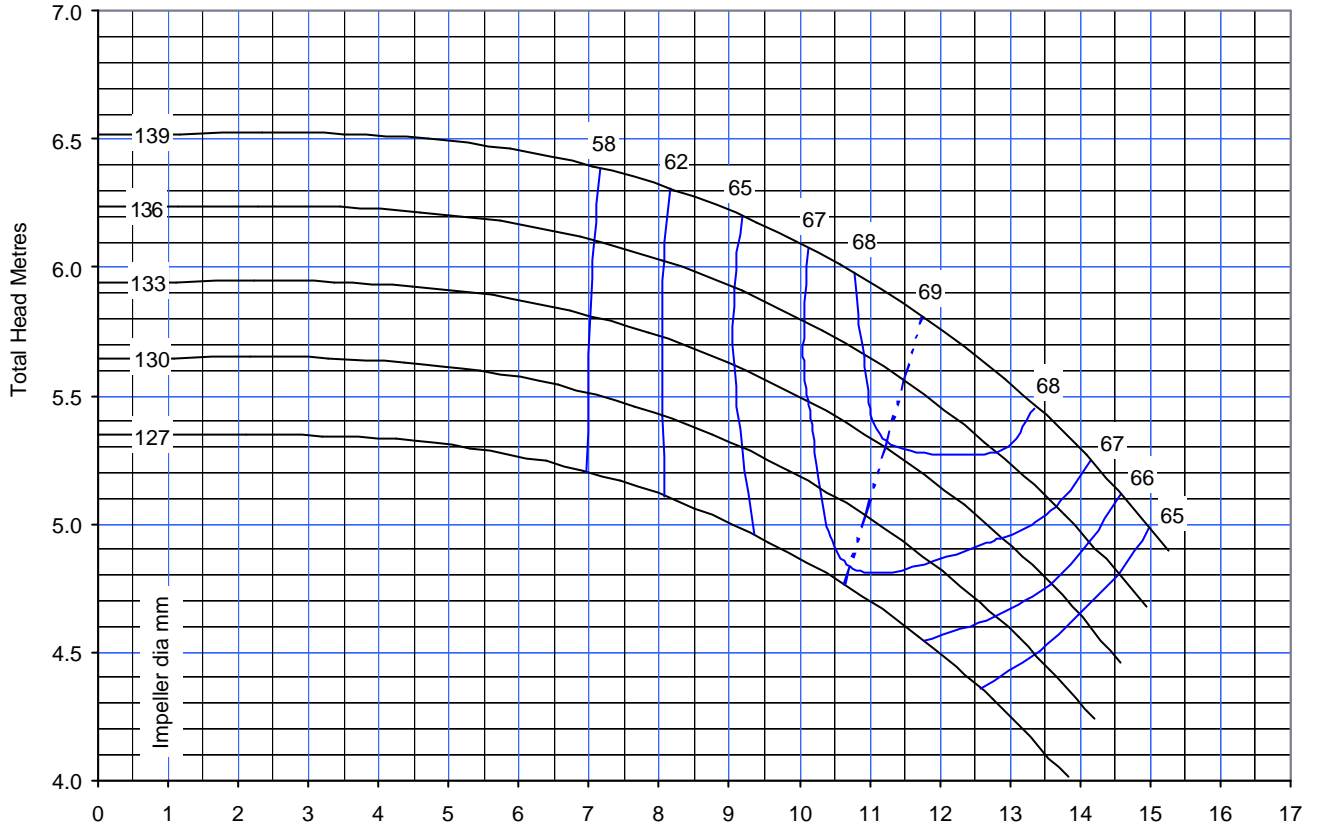
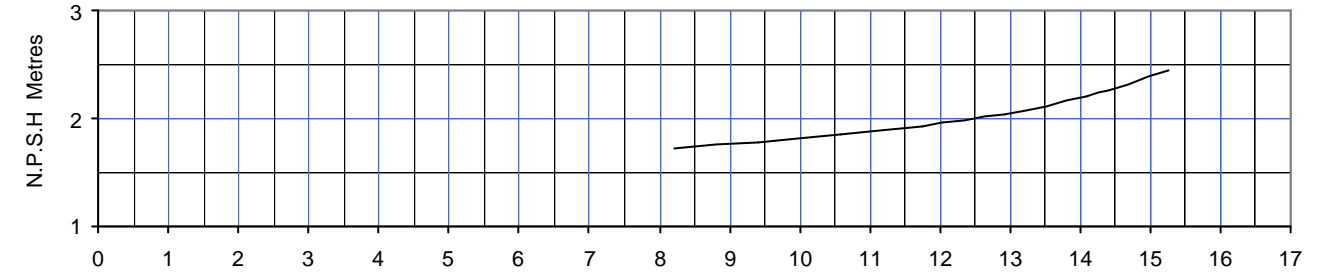

SUCTION DIA 80	DISCHARGE DIA 65	MAX PRESSURE 12 bar	PUMP MODEL TD 65-125	SPEED 1420
--------------------------	----------------------------	-------------------------------	--------------------------------	----------------------

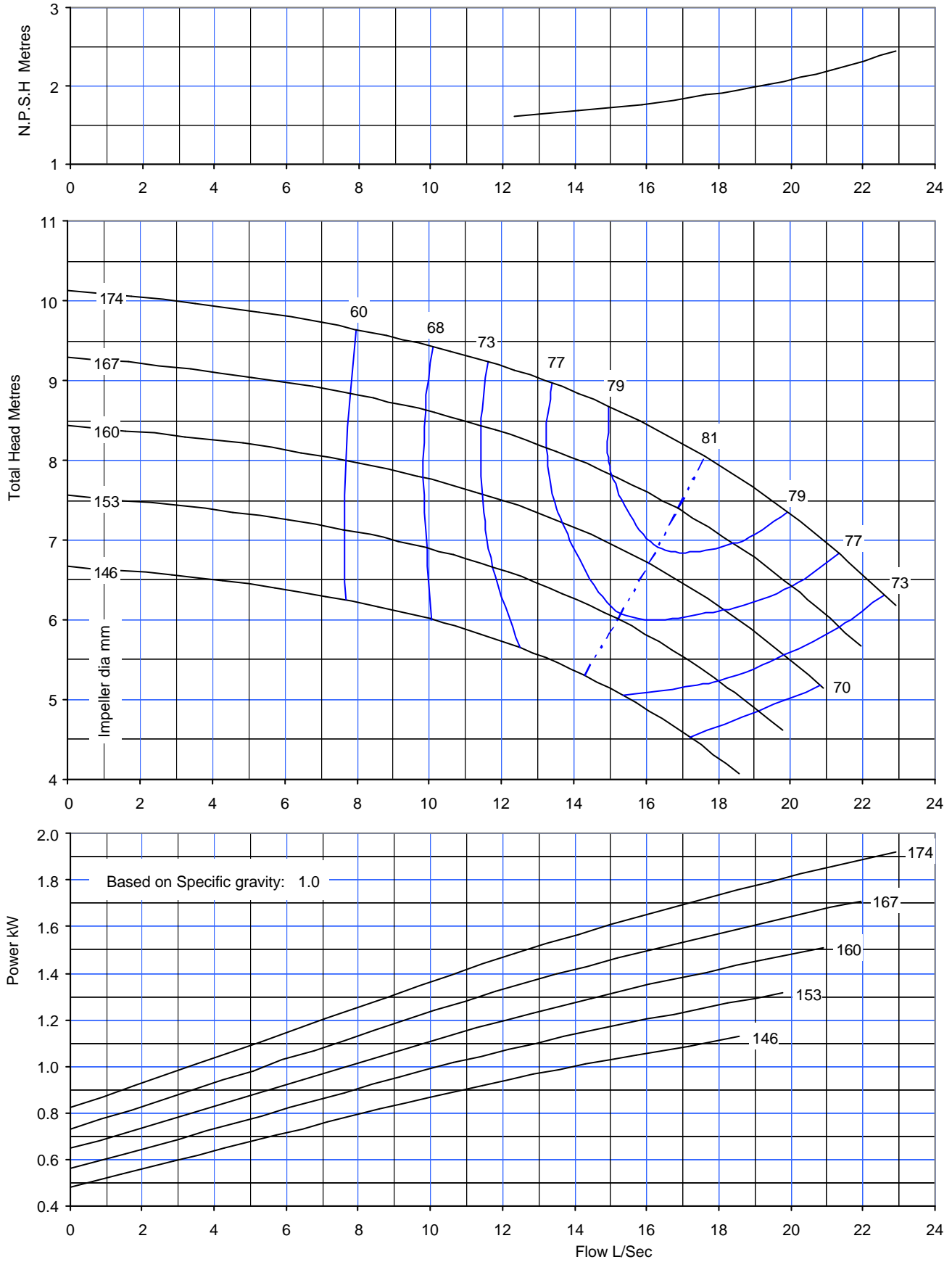

SUCTION DIA 80	DISCHARGE DIA 65	MAX PRESSURE 12 bar	PUMP MODEL TD 65-160	SPEED 1420
--------------------------	----------------------------	-------------------------------	--------------------------------	----------------------

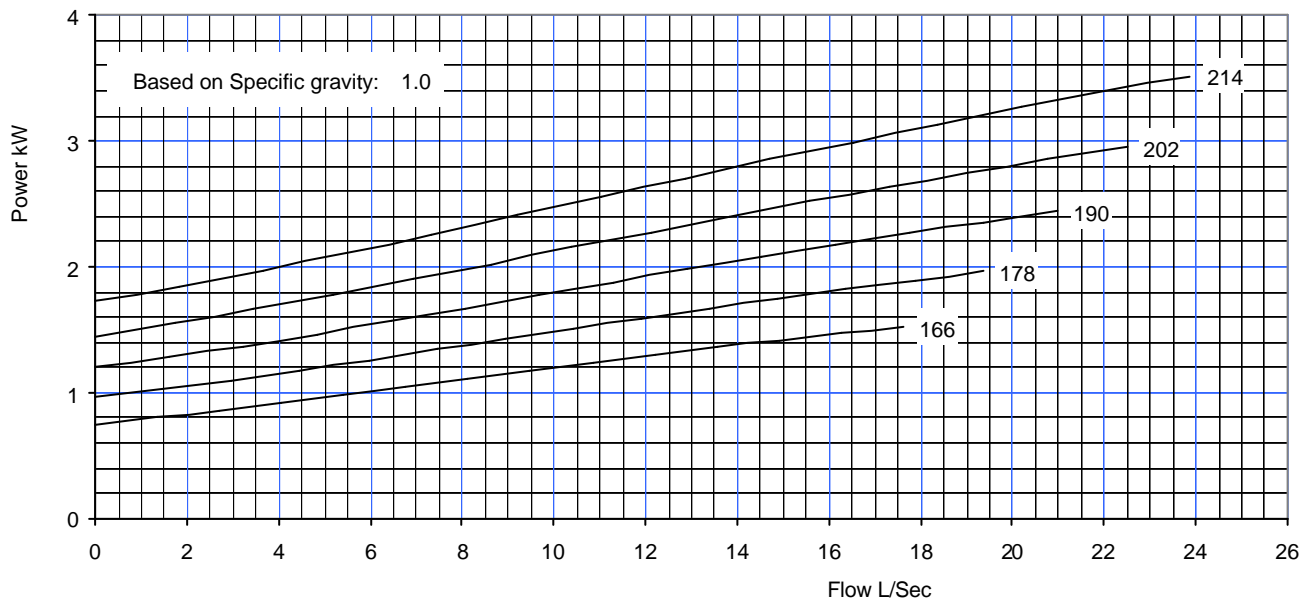
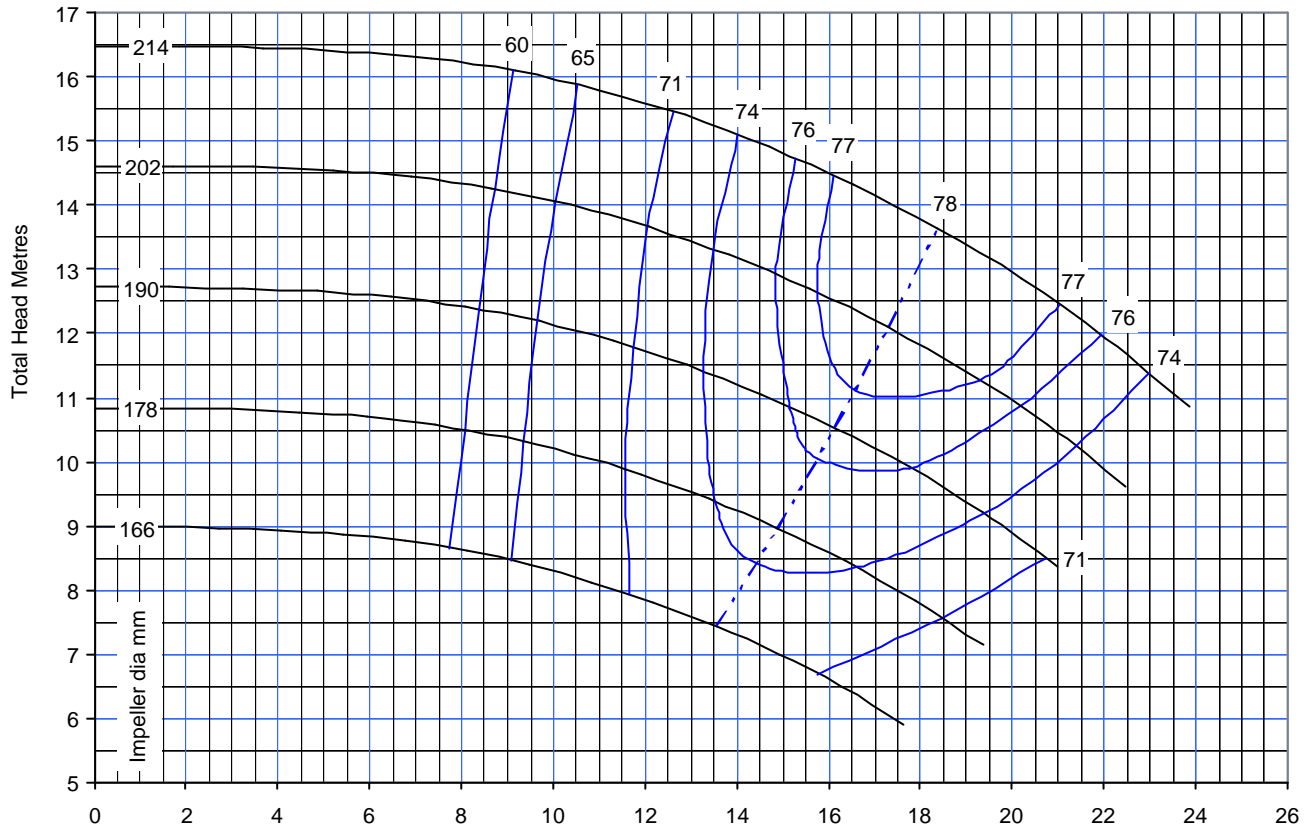
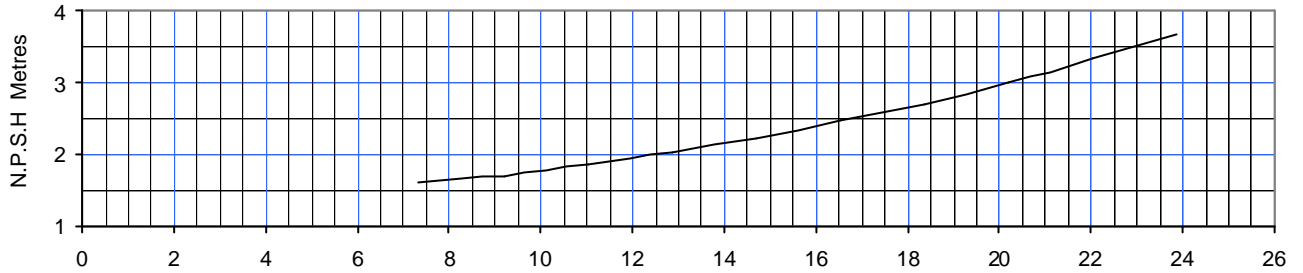

SUCTION DIA 80	DISCHARGE DIA 65	MAX PRESSURE 12 bar	PUMP MODEL TD 65-200	SPEED 1440
--------------------------	----------------------------	-------------------------------	--------------------------------	----------------------

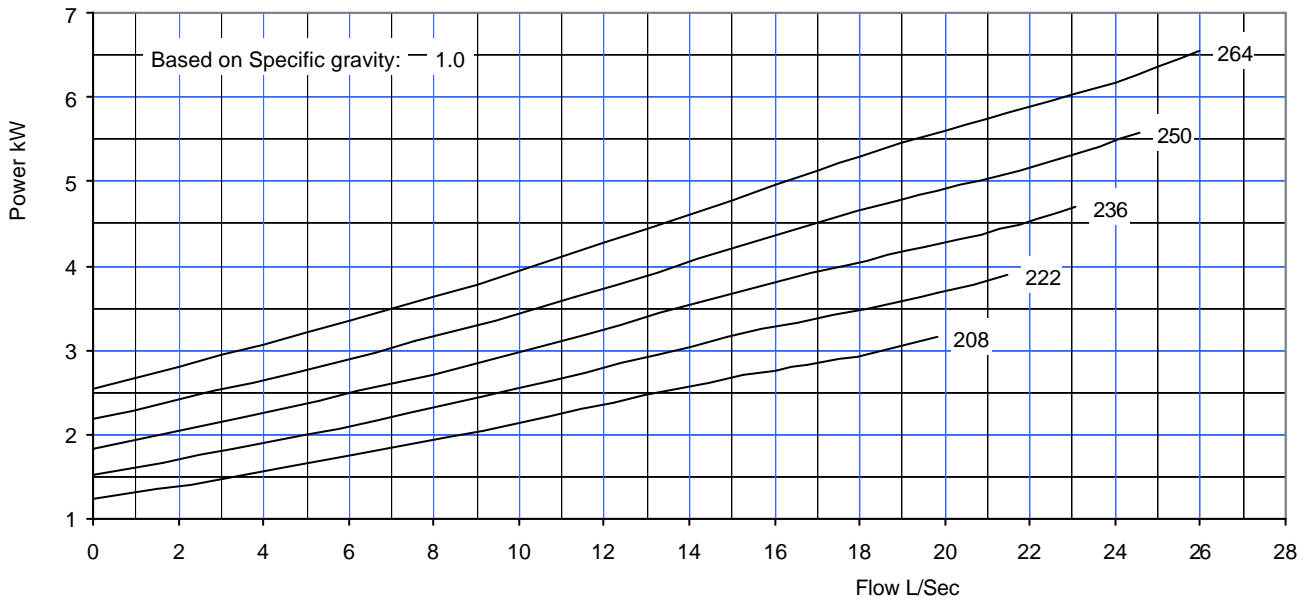
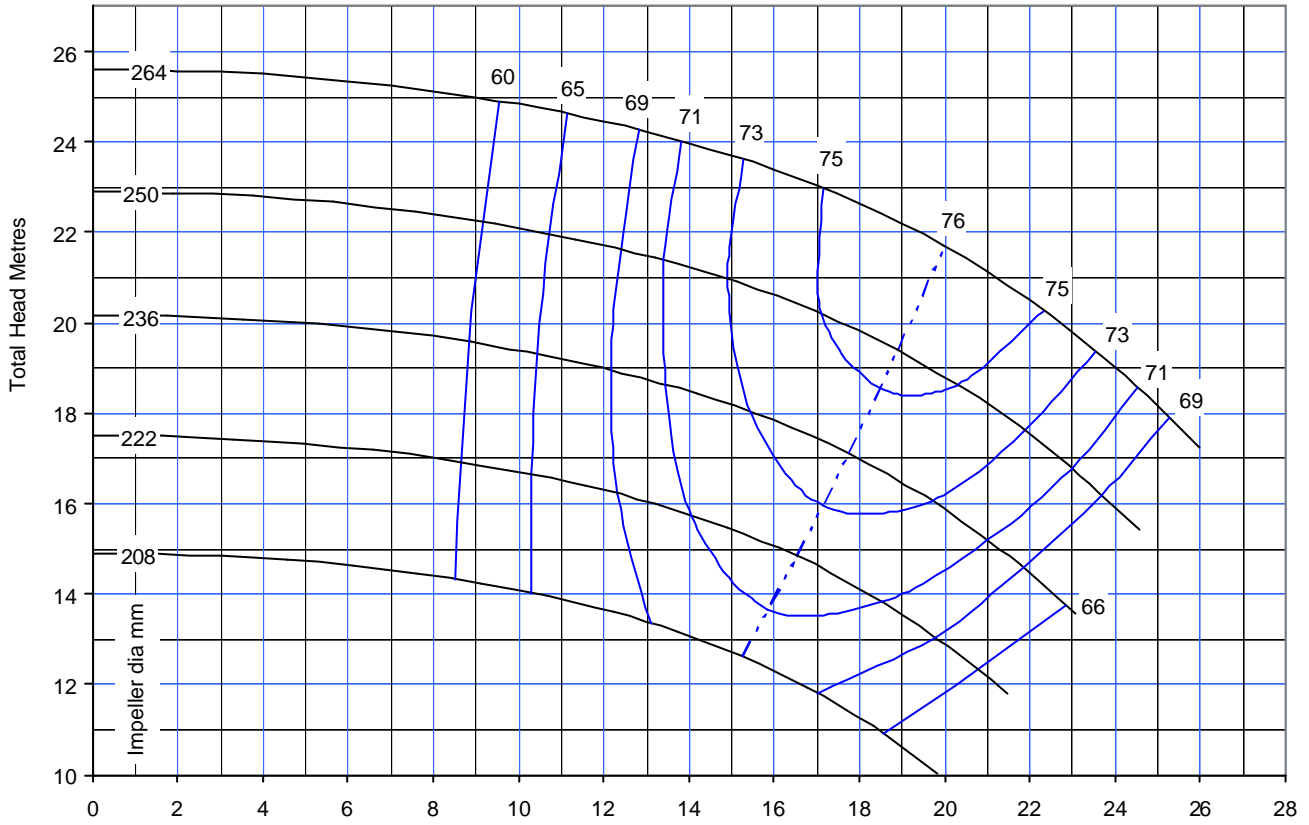
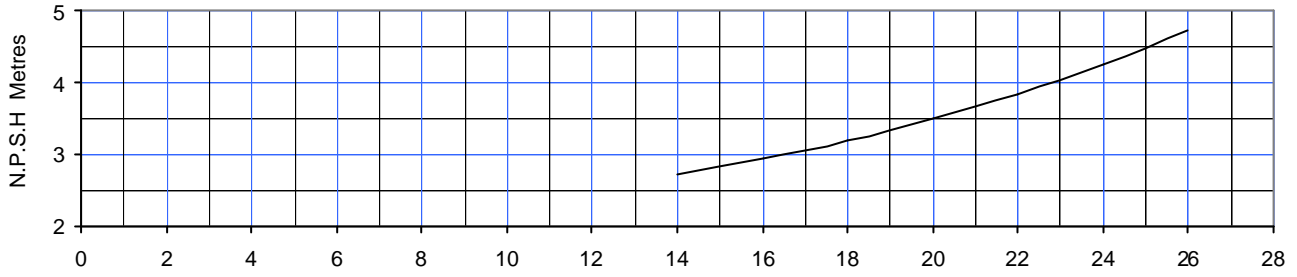

SUCTION DIA 80	DISCHARGE DIA 65	MAX PRESSURE 12 bar	PUMP MODEL TD 65-250	SPEED 1450
--------------------------	----------------------------	-------------------------------	--------------------------------	----------------------

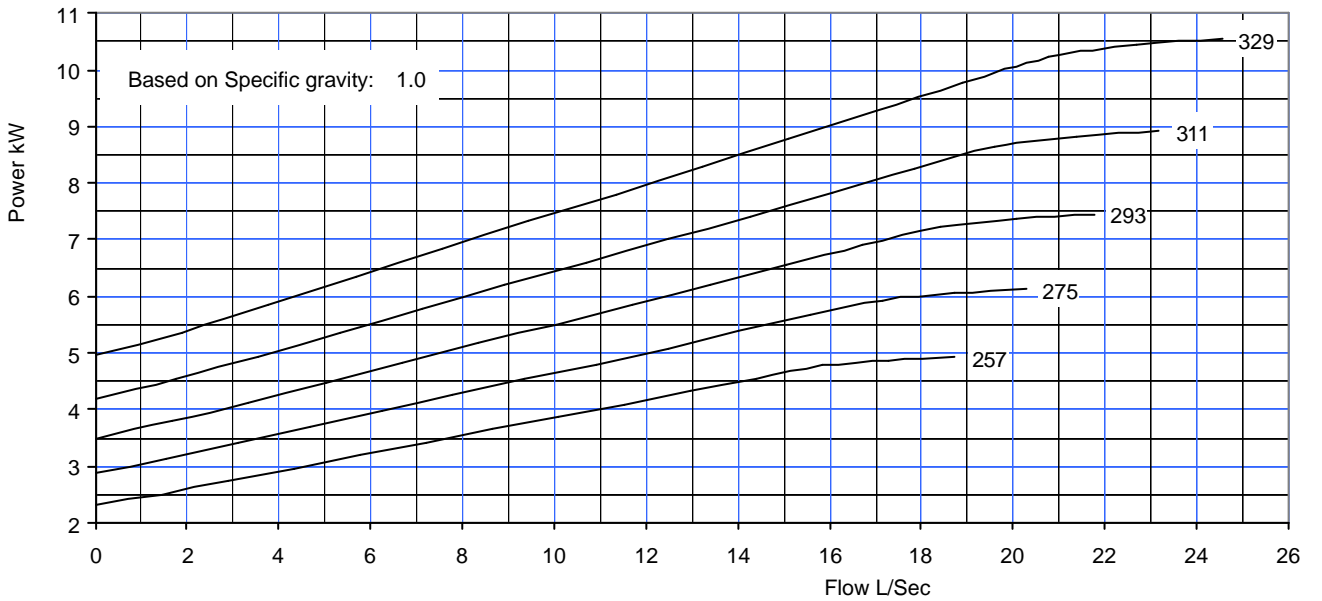
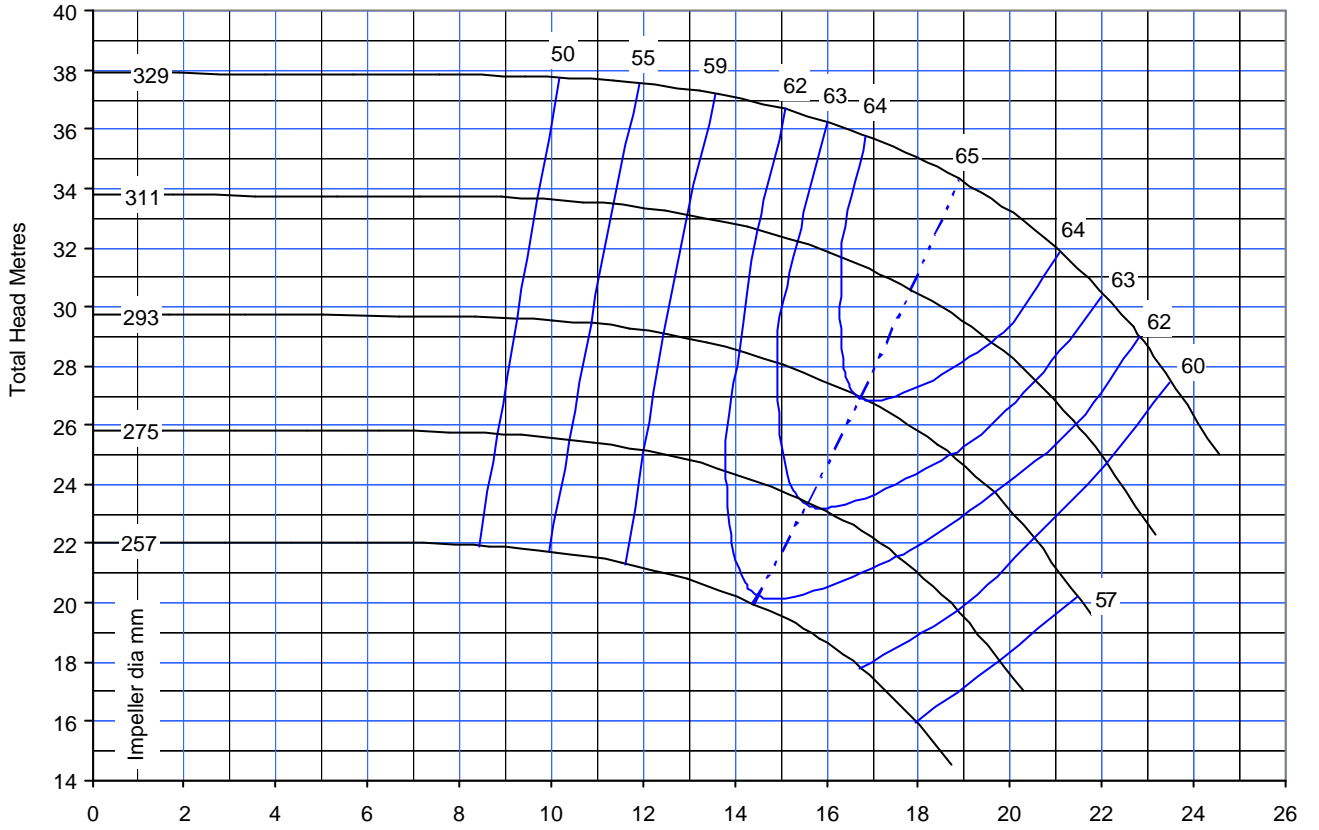
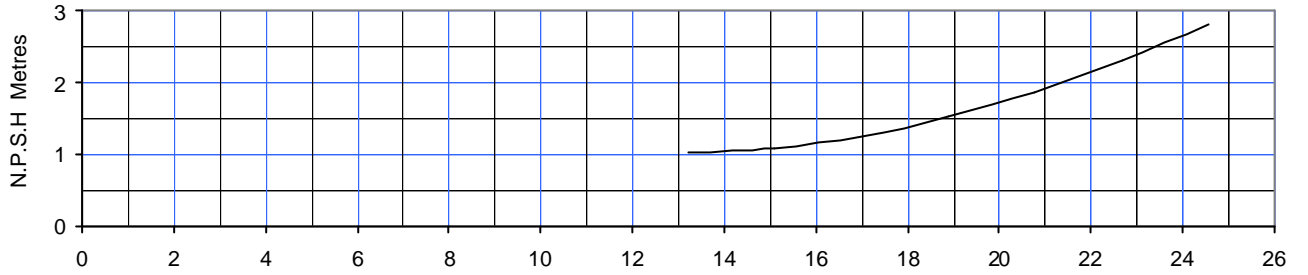

SUCTION DIA 80	DISCHARGE DIA 65	MAX PRESSURE 12 bar	PUMP MODEL TD 65-315	SPEED 1450
--------------------------	----------------------------	-------------------------------	--------------------------------	----------------------

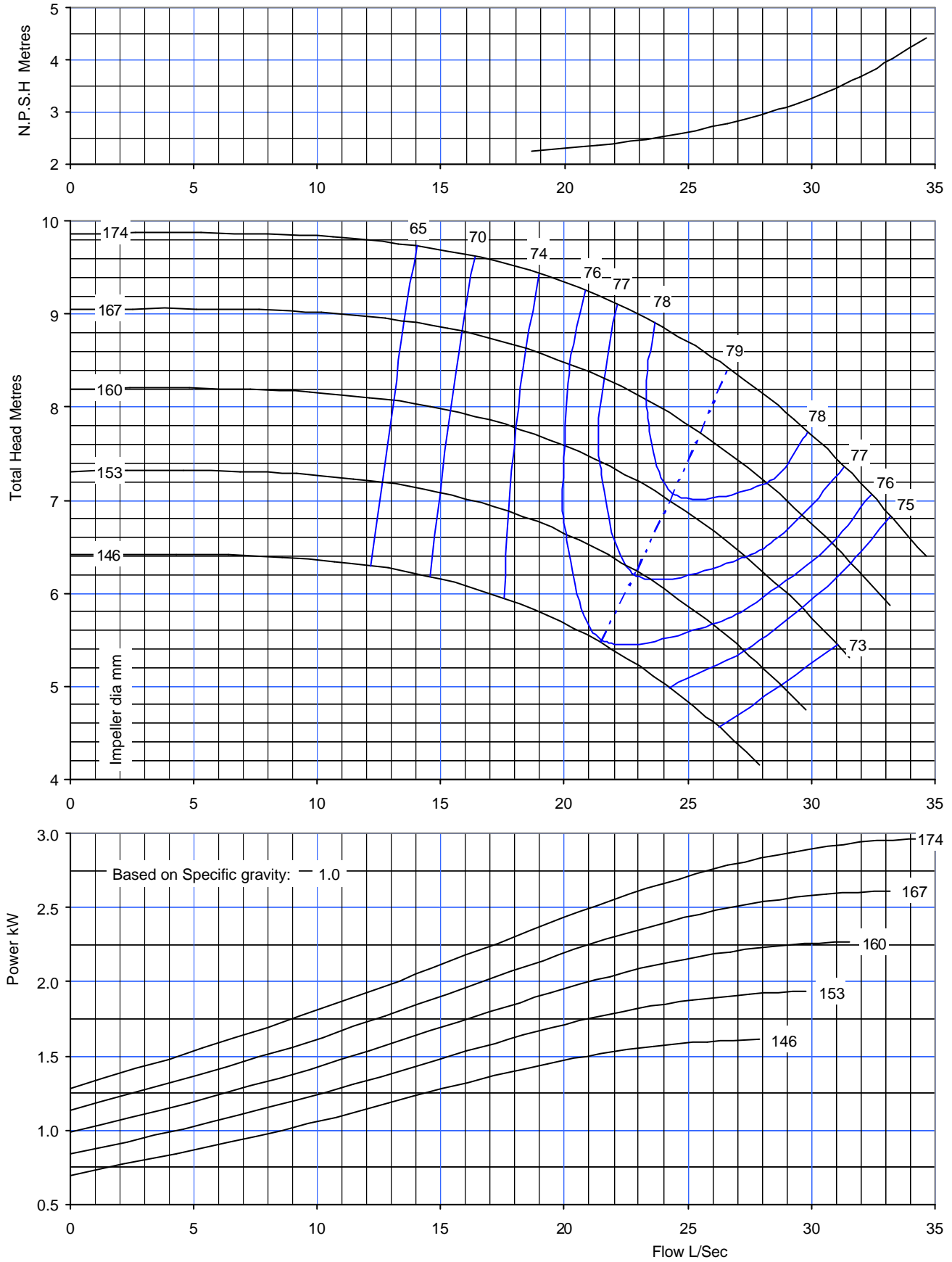

SUCTION DIA 100	DISCHARGE DIA 80	MAX PRESSURE 12 bar	PUMP MODEL TD 80-160	SPEED 1420
---------------------------	----------------------------	-------------------------------	--------------------------------	----------------------

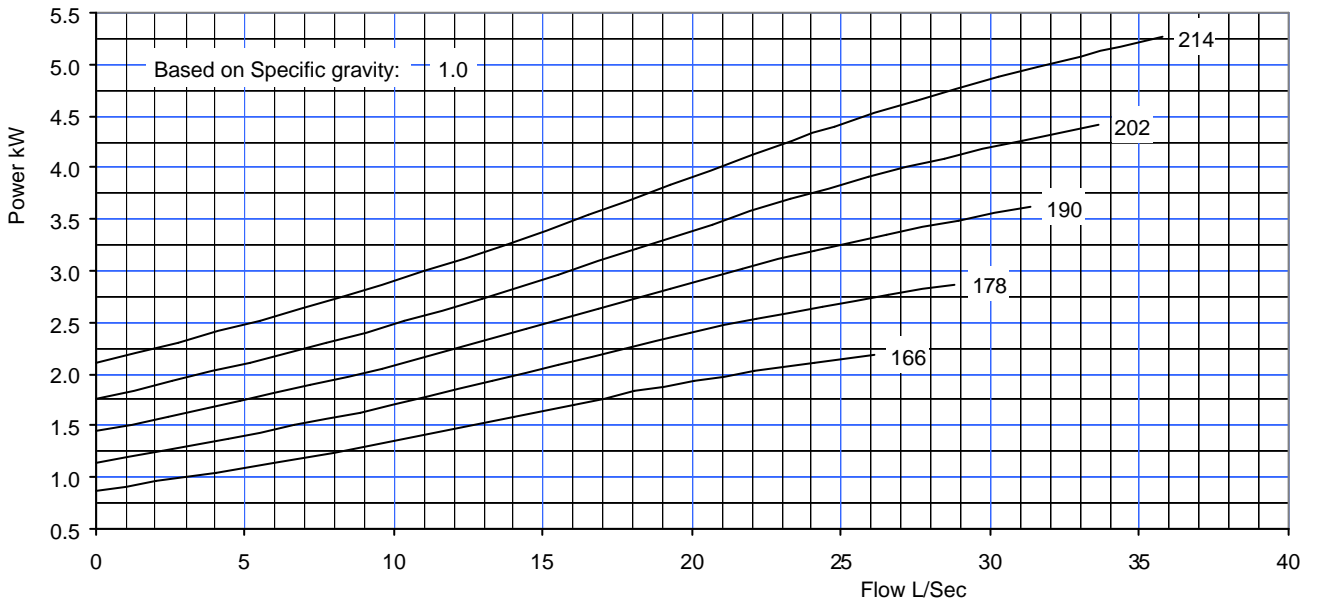
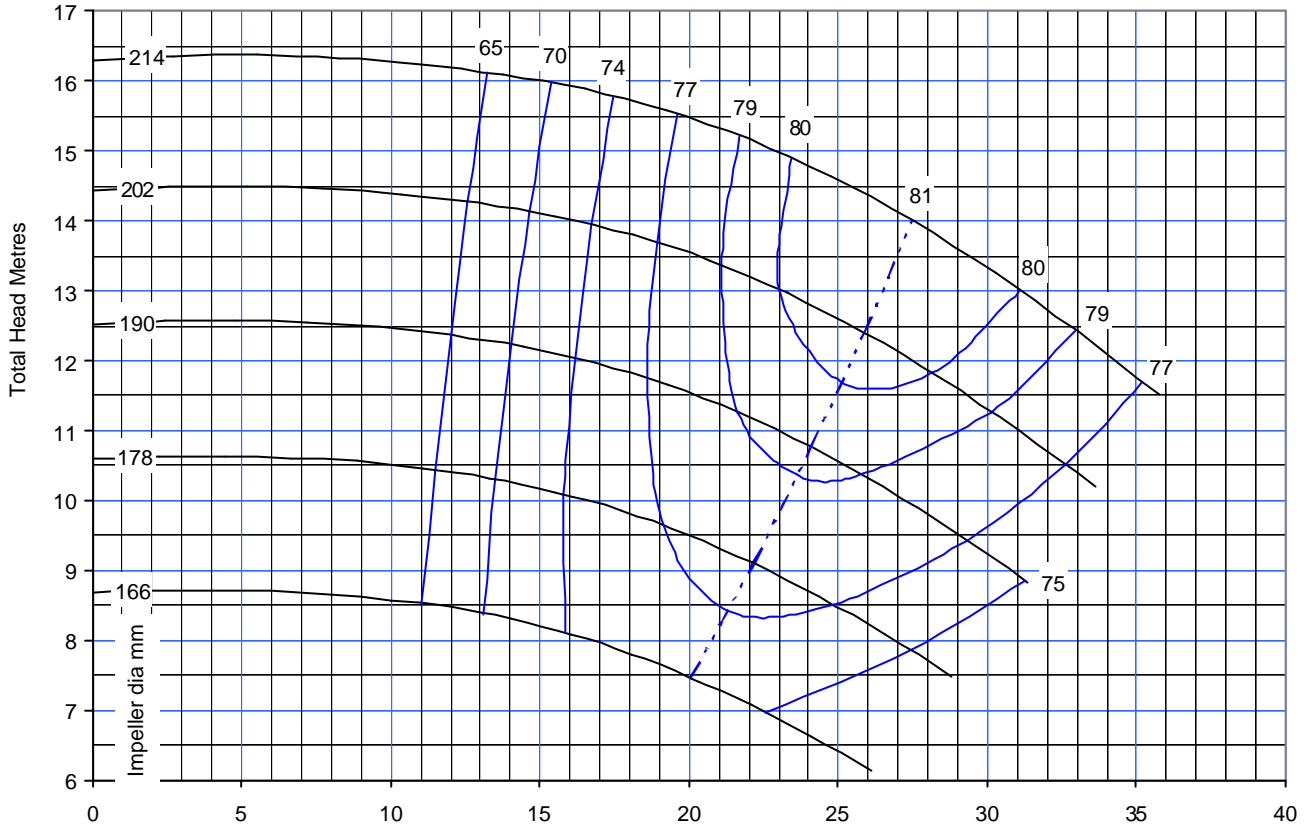
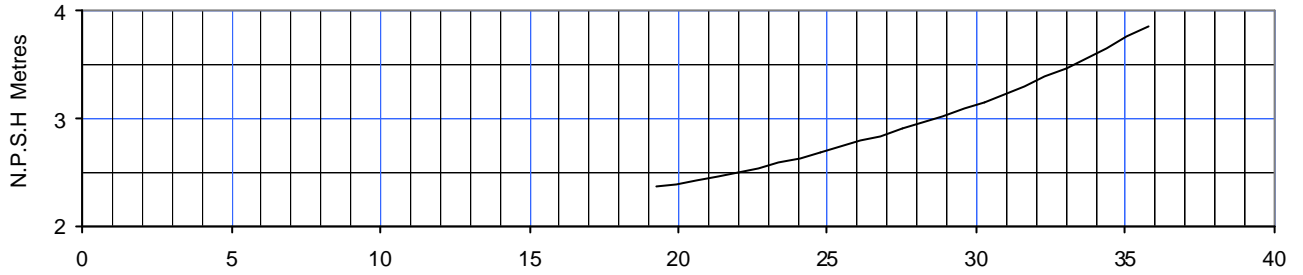

SUCTION DIA 100	DISCHARGE DIA 80	MAX PRESSURE 12 bar	PUMP MODEL TD 80-200	SPEED 1450
---------------------------	----------------------------	-------------------------------	--------------------------------	----------------------

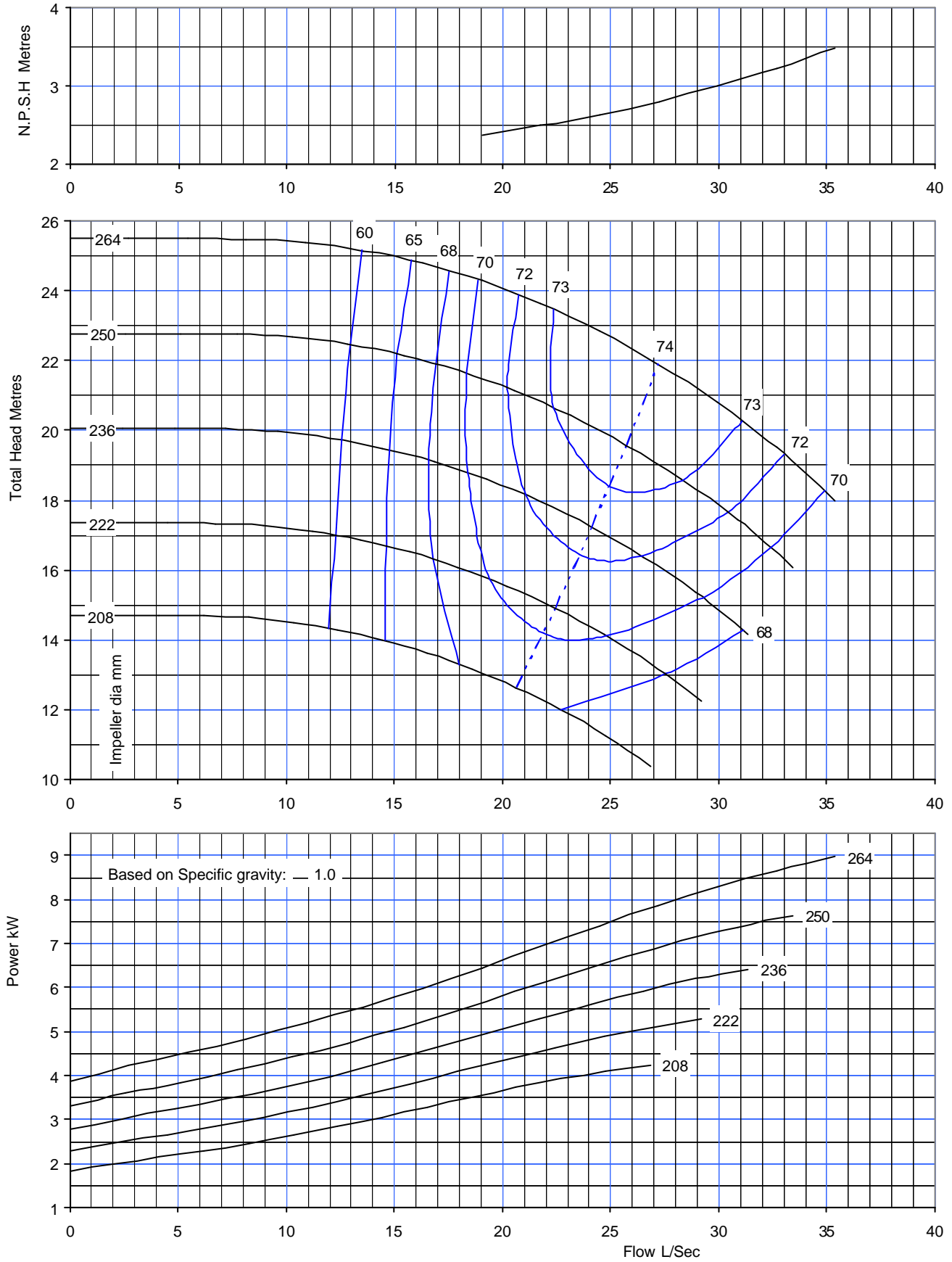

SUCTION DIA 100	DISCHARGE DIA 80	MAX PRESSURE 12 bar	PUMP MODEL TD 80-250	SPEED 1450
---------------------------	----------------------------	-------------------------------	--------------------------------	----------------------

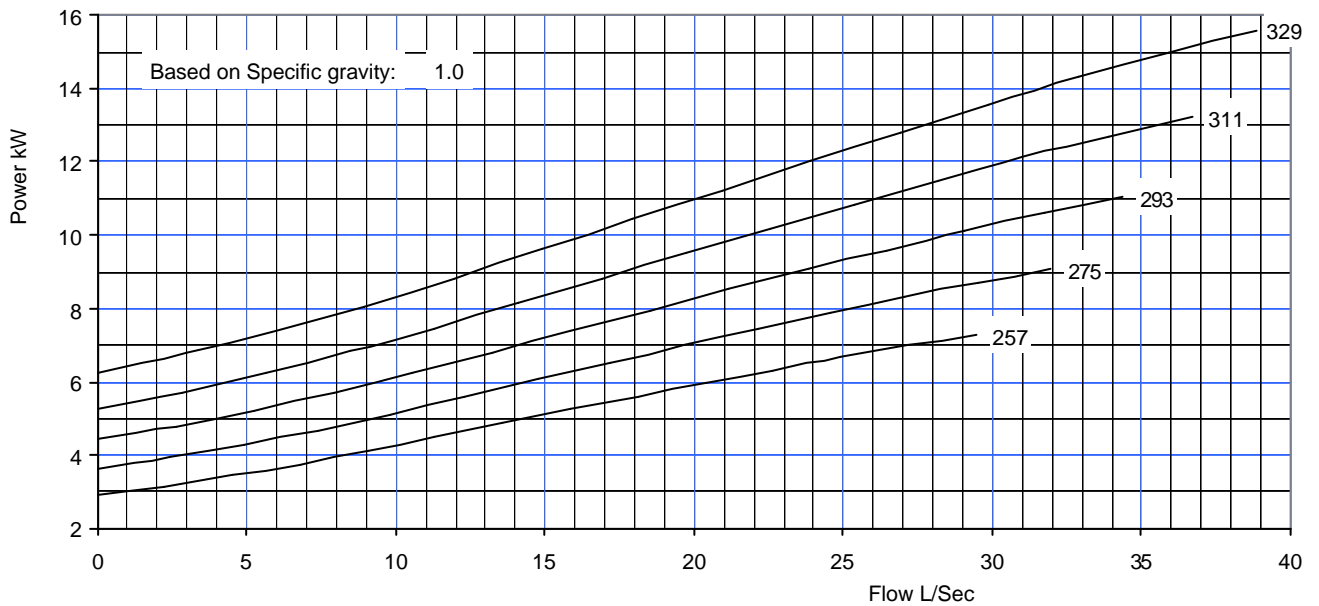
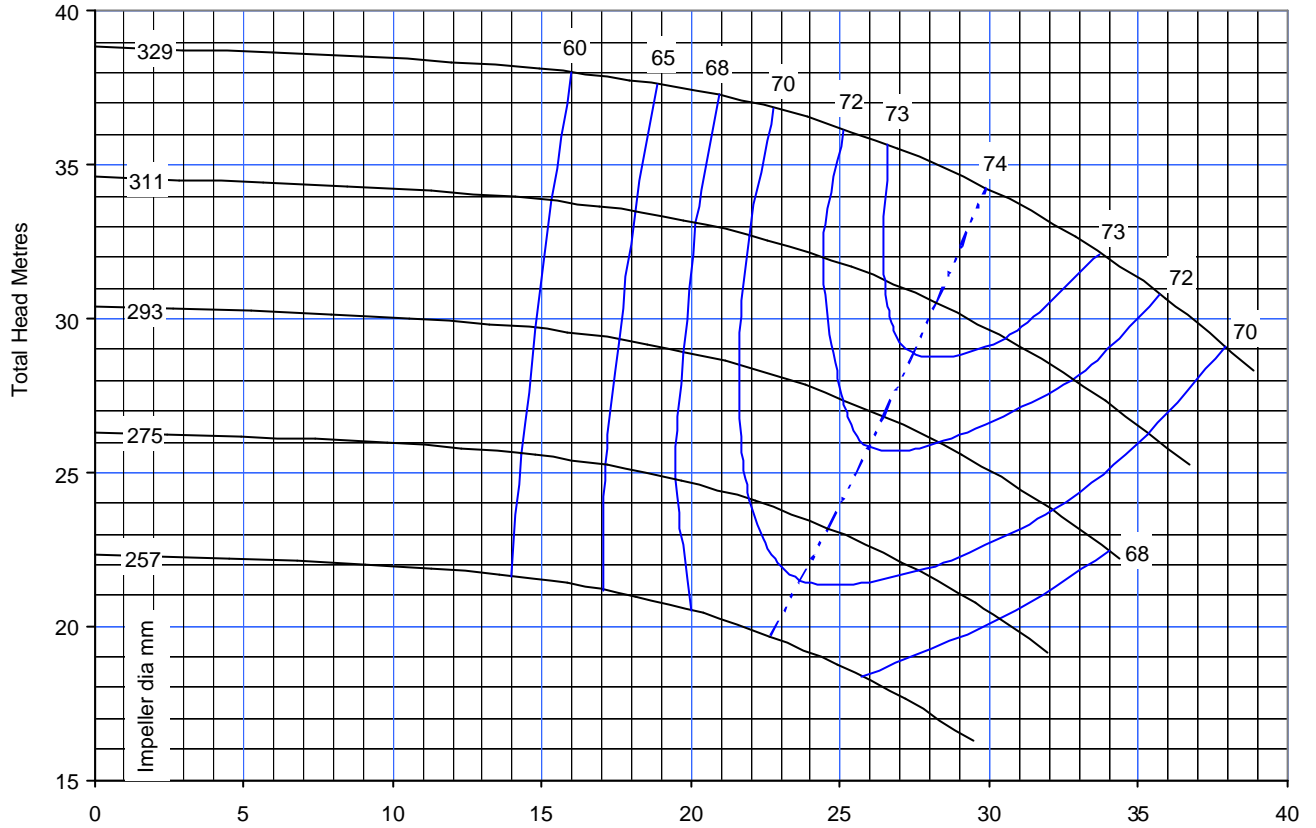
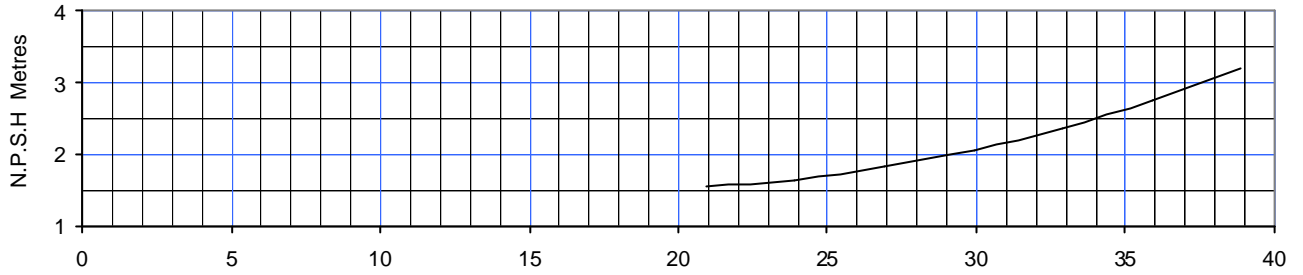

SUCTION DIA 100	DISCHARGE DIA 80	MAX PRESSURE 12 bar	PUMP MODEL TD 80-315	SPEED 1470
---------------------------	----------------------------	-------------------------------	--------------------------------	----------------------

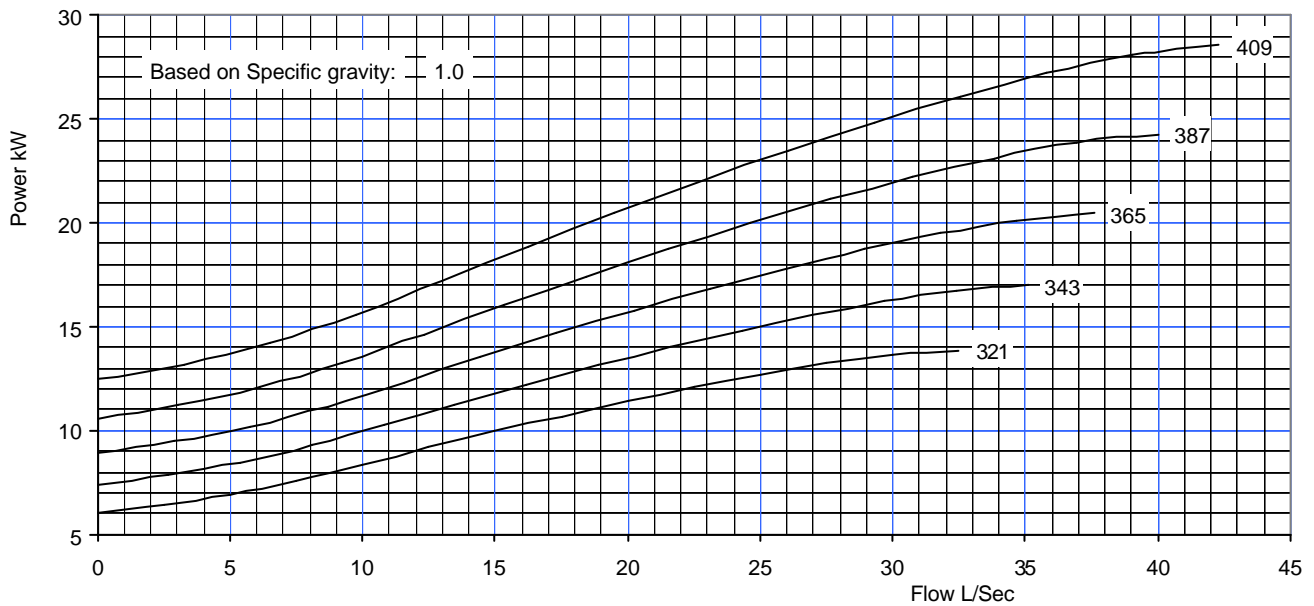
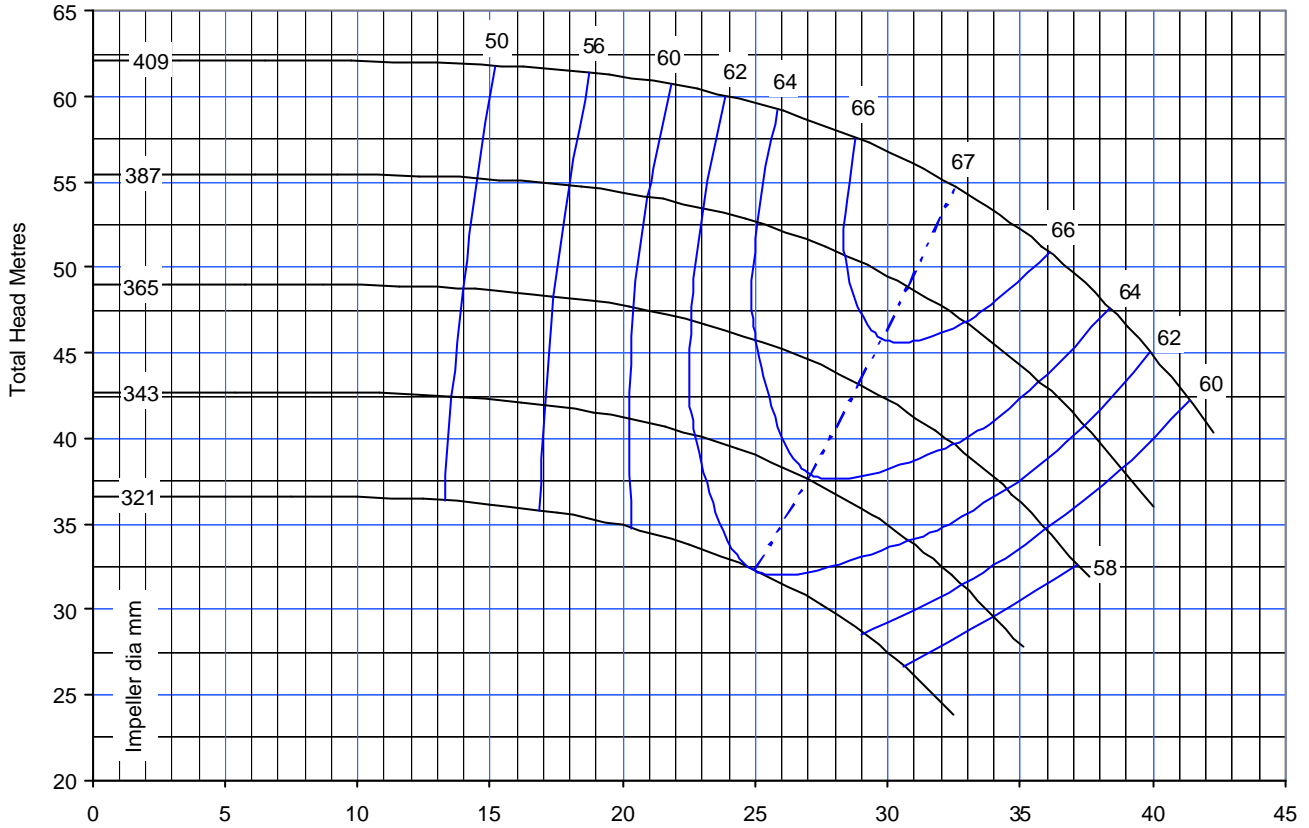
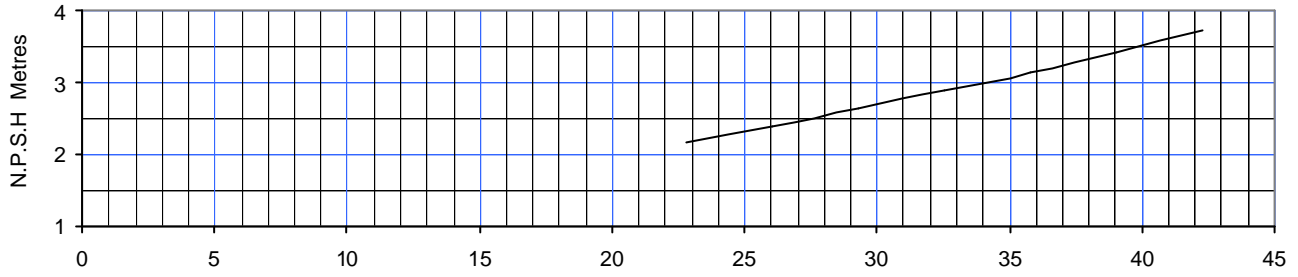

SUCTION DIA 100	DISCHARGE DIA 80	MAX PRESSURE 12 bar	PUMP MODEL TD 80-400	SPEED 1475
---------------------------	----------------------------	-------------------------------	--------------------------------	----------------------

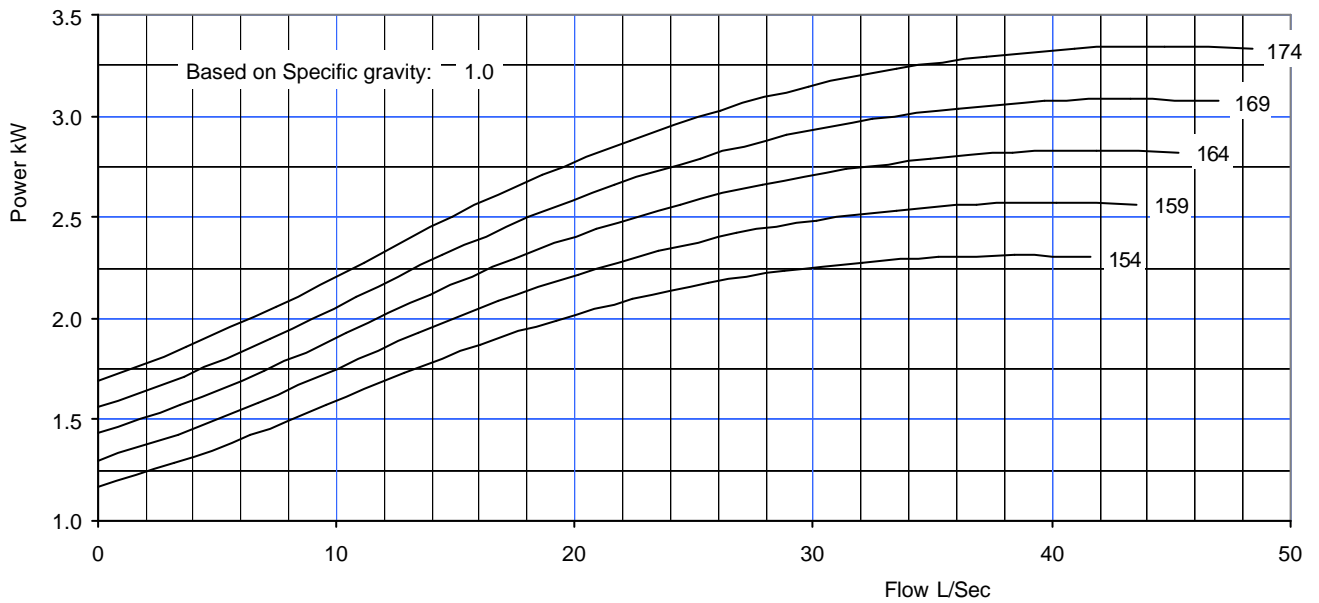
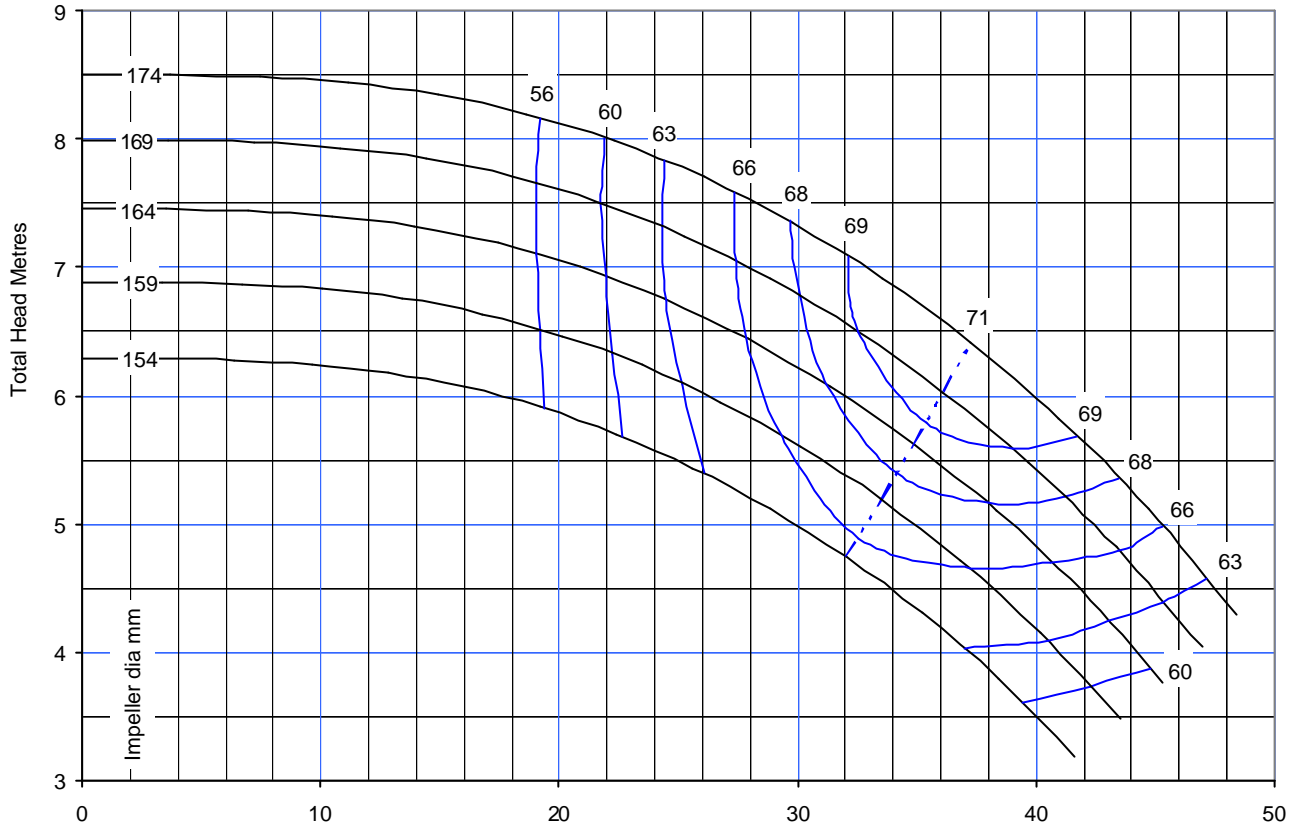
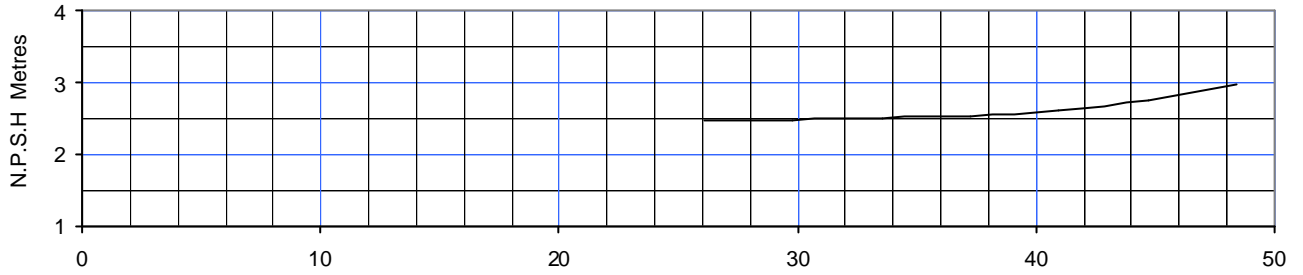

SUCTION DIA 125	DISCHARGE DIA 100	MAX PRESSURE 12 bar	PUMP MODEL TD 100-160	SPEED 1440
---------------------------	-----------------------------	-------------------------------	---------------------------------	----------------------

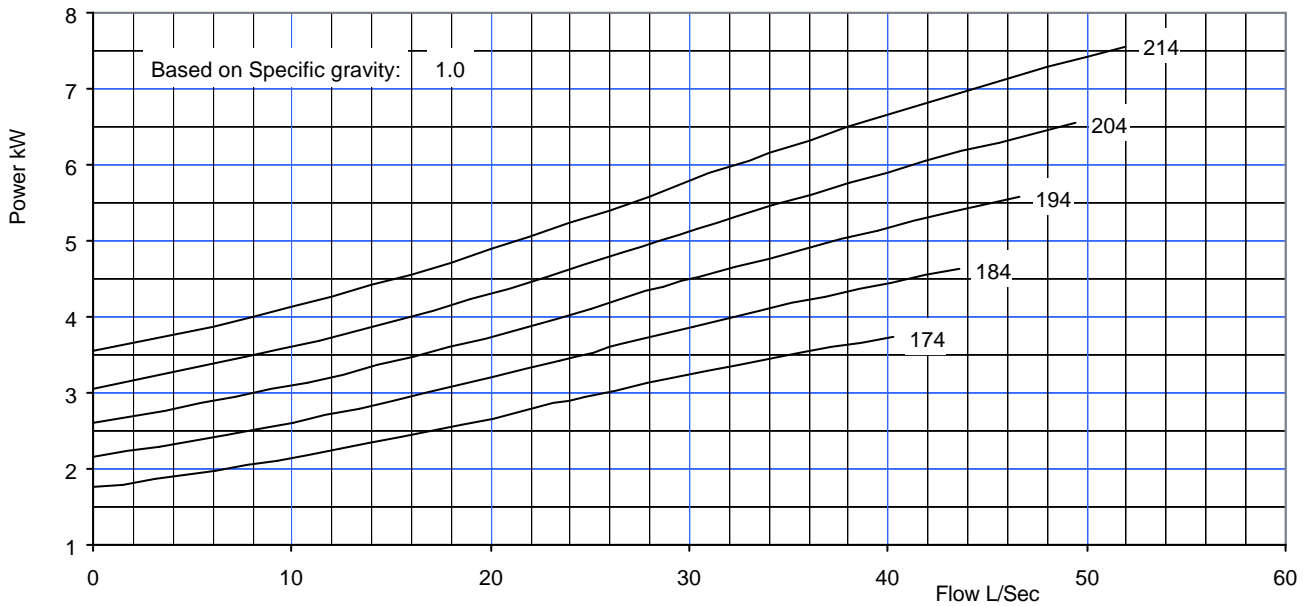
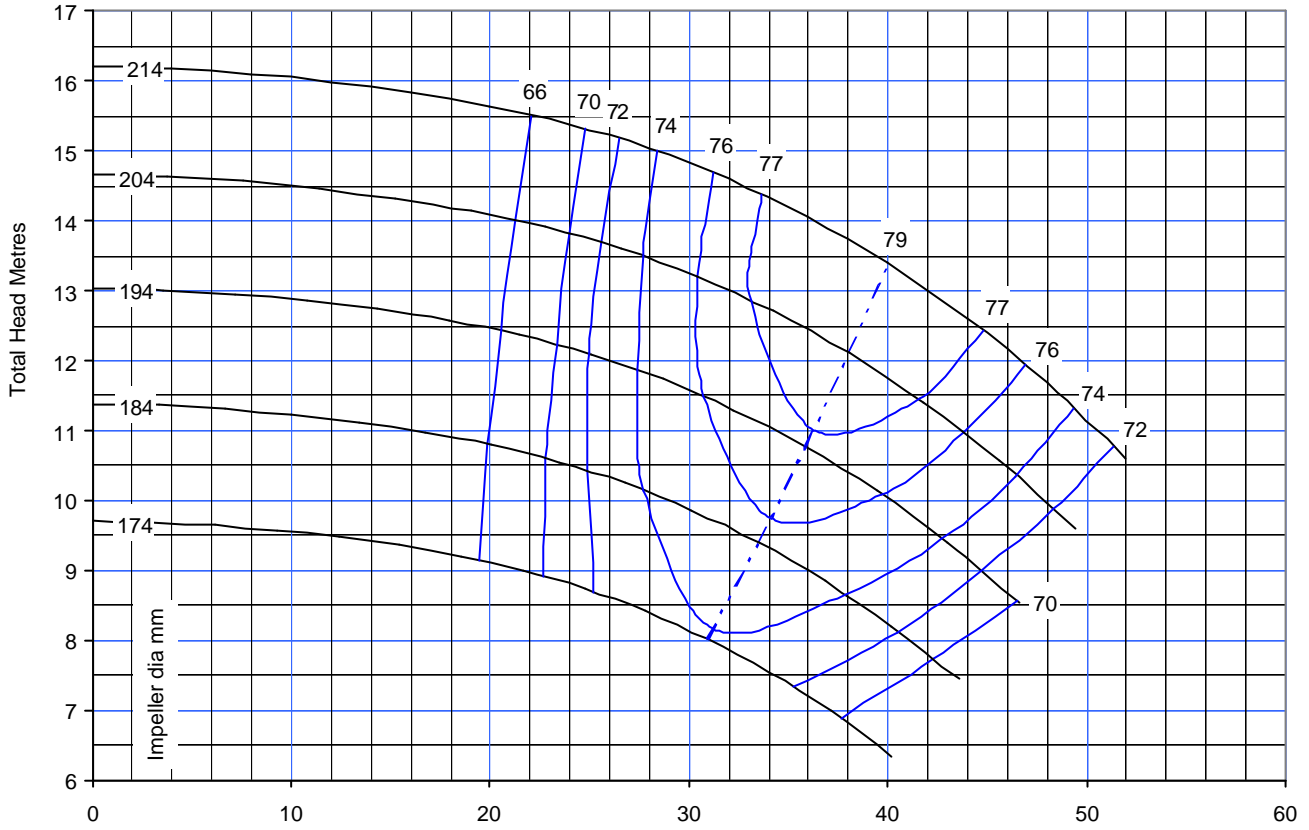
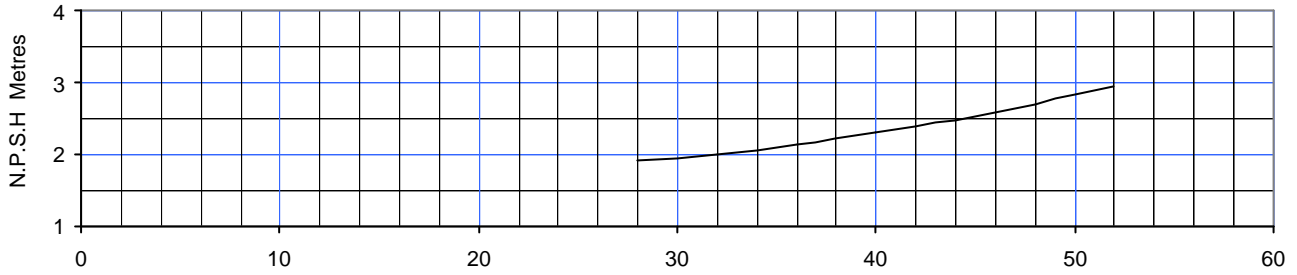

SUCTION DIA 125	DISCHARGE DIA 100	MAX PRESSURE 12 bar	PUMP MODEL TD 100-200	SPEED 1450
---------------------------	-----------------------------	-------------------------------	---------------------------------	----------------------

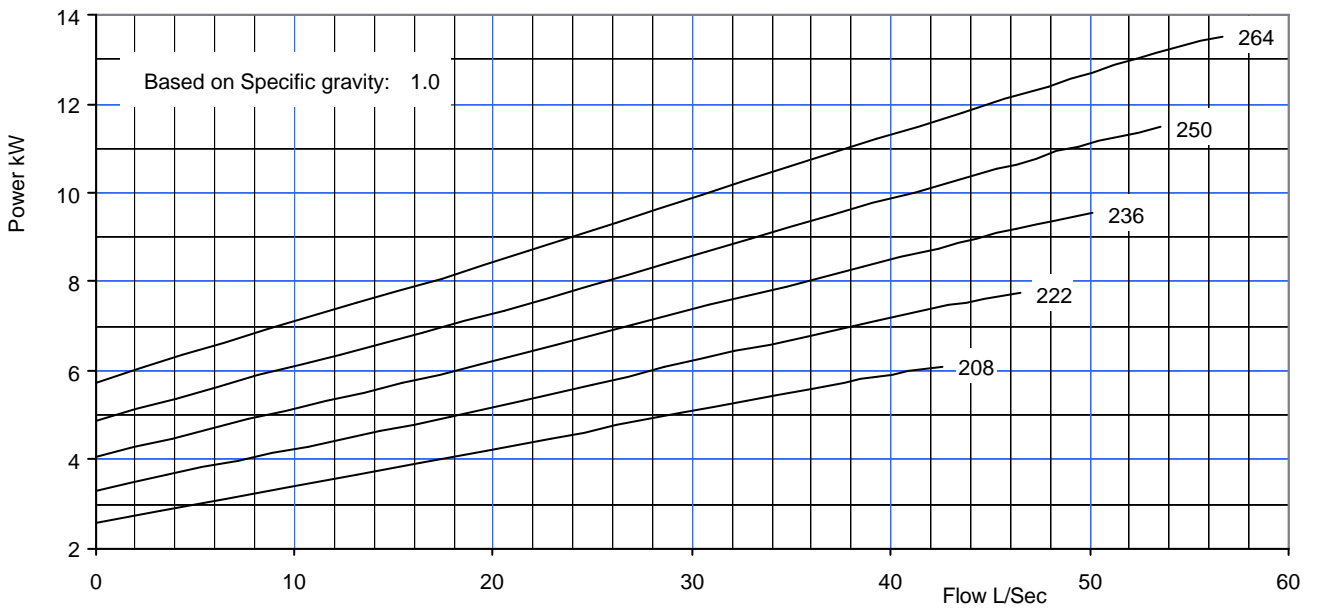
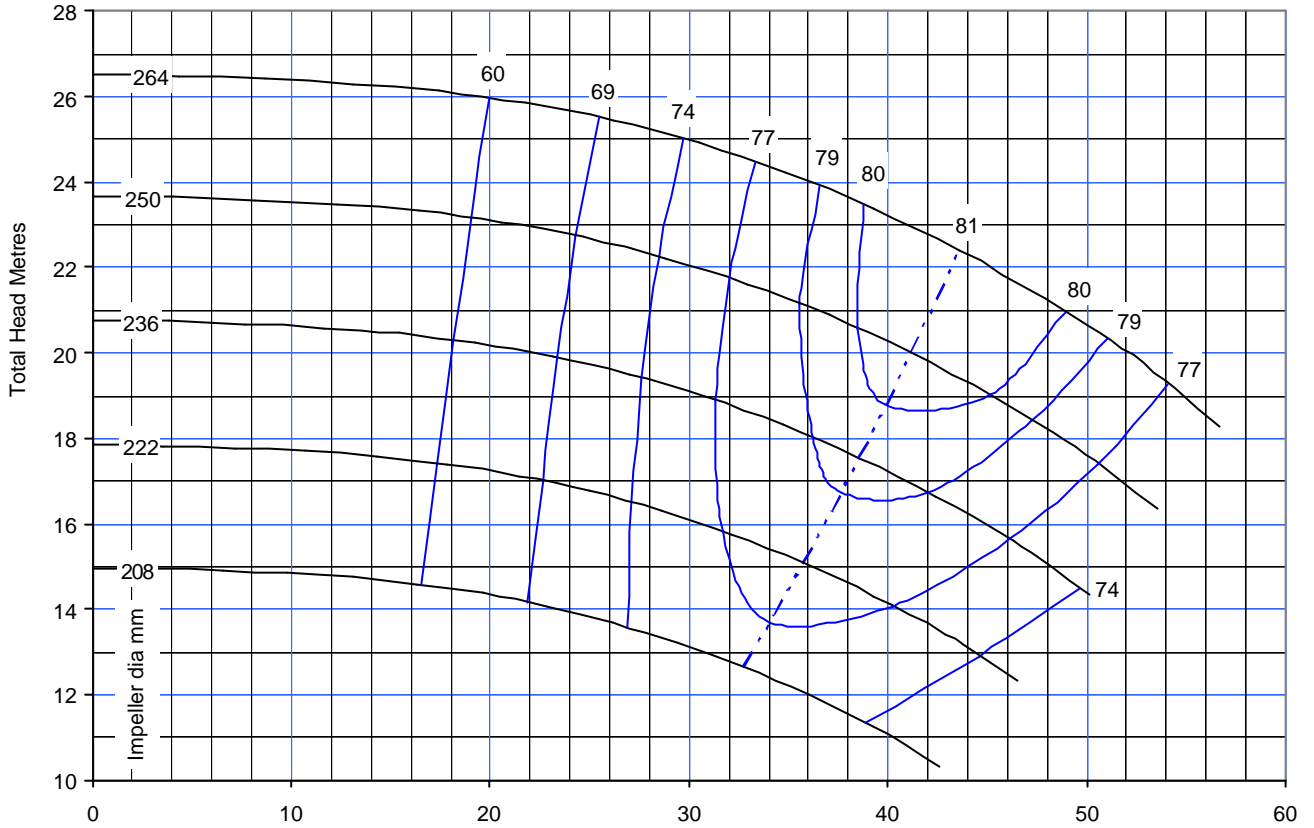
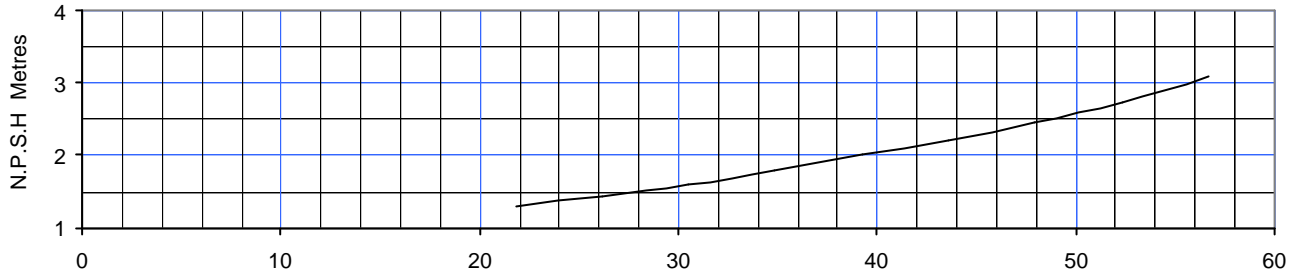

SUCTION DIA 125	DISCHARGE DIA 100	MAX PRESSURE 16 bar	PUMP MODEL TD 100-250	SPEED 1470
---------------------------	-----------------------------	-------------------------------	---------------------------------	----------------------

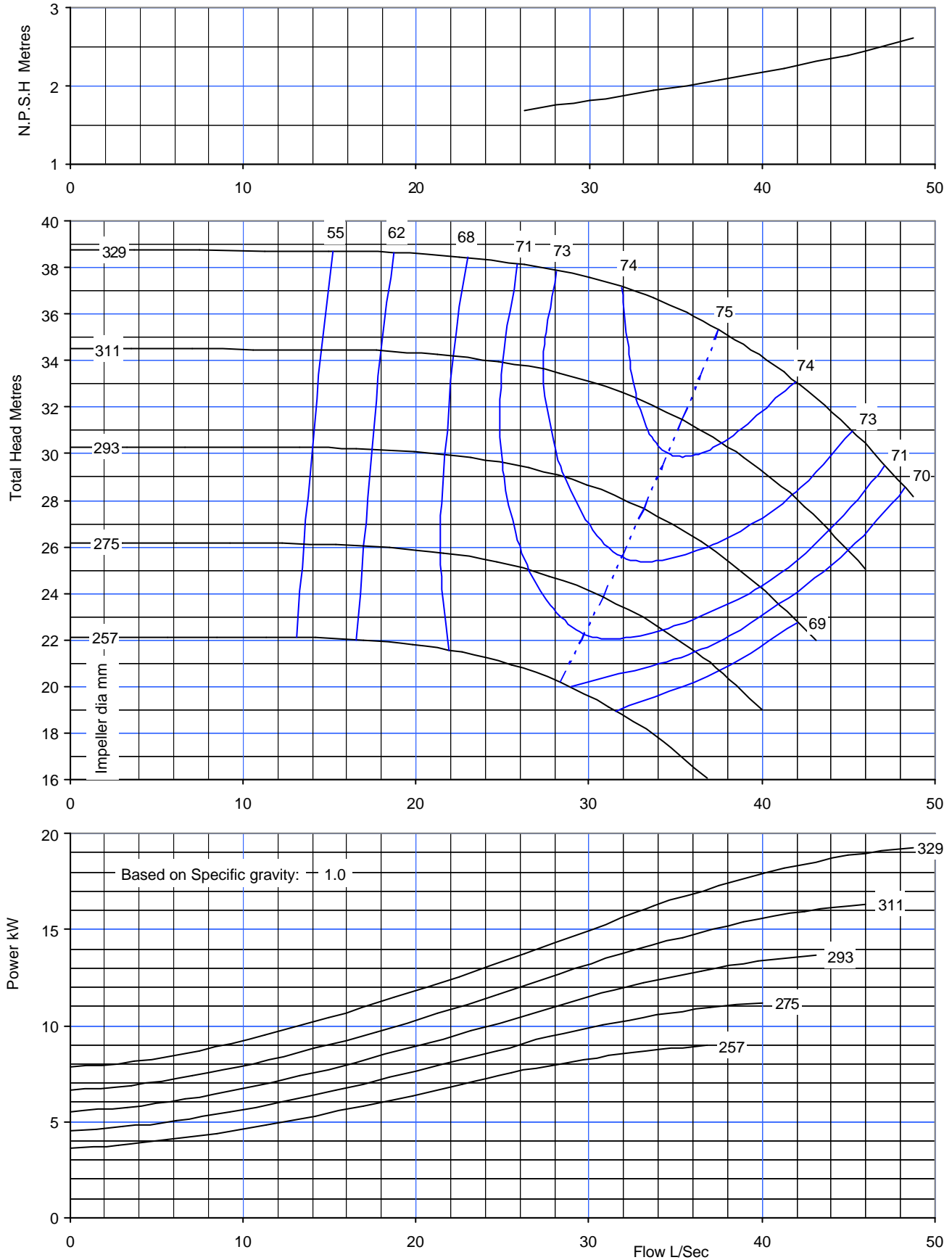

SUCTION DIA 125	DISCHARGE DIA 100	MAX PRESSURE 12 bar	PUMP MODEL TD 100-315	SPEED 1470
---------------------------	-----------------------------	-------------------------------	---------------------------------	----------------------

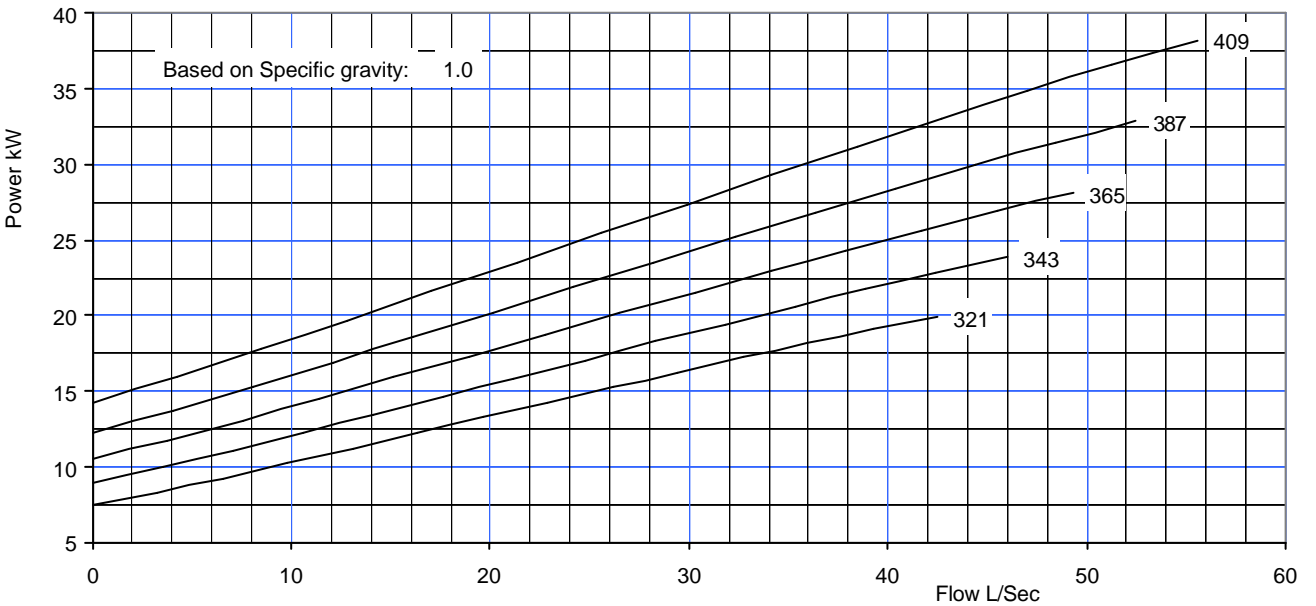
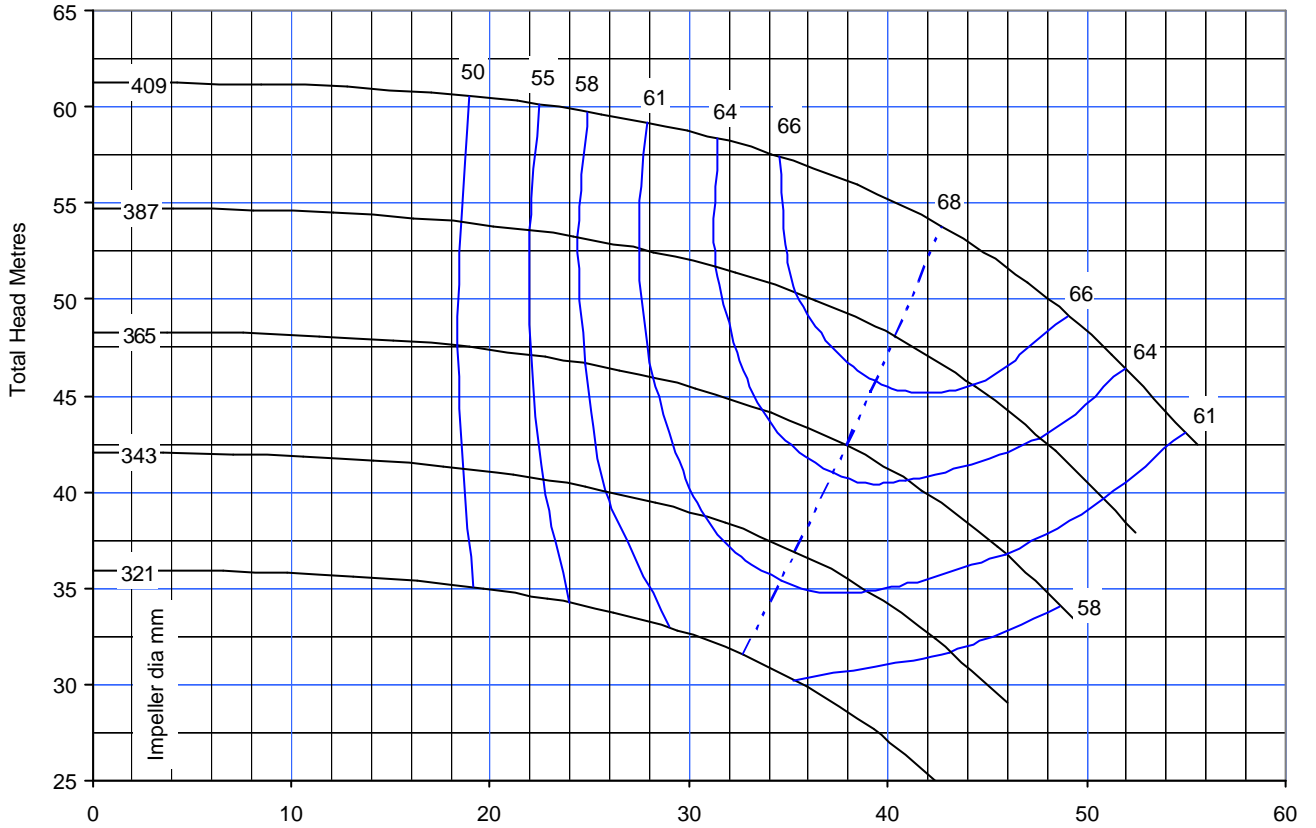
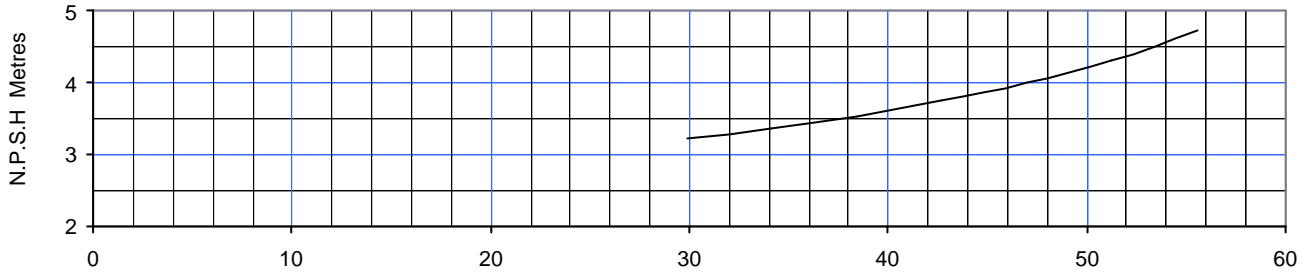

SUCTION DIA 125	DISCHARGE DIA 100	MAX PRESSURE 12 bar	PUMP MODEL TD 100-400	SPEED 1475
---------------------------	-----------------------------	-------------------------------	---------------------------------	----------------------

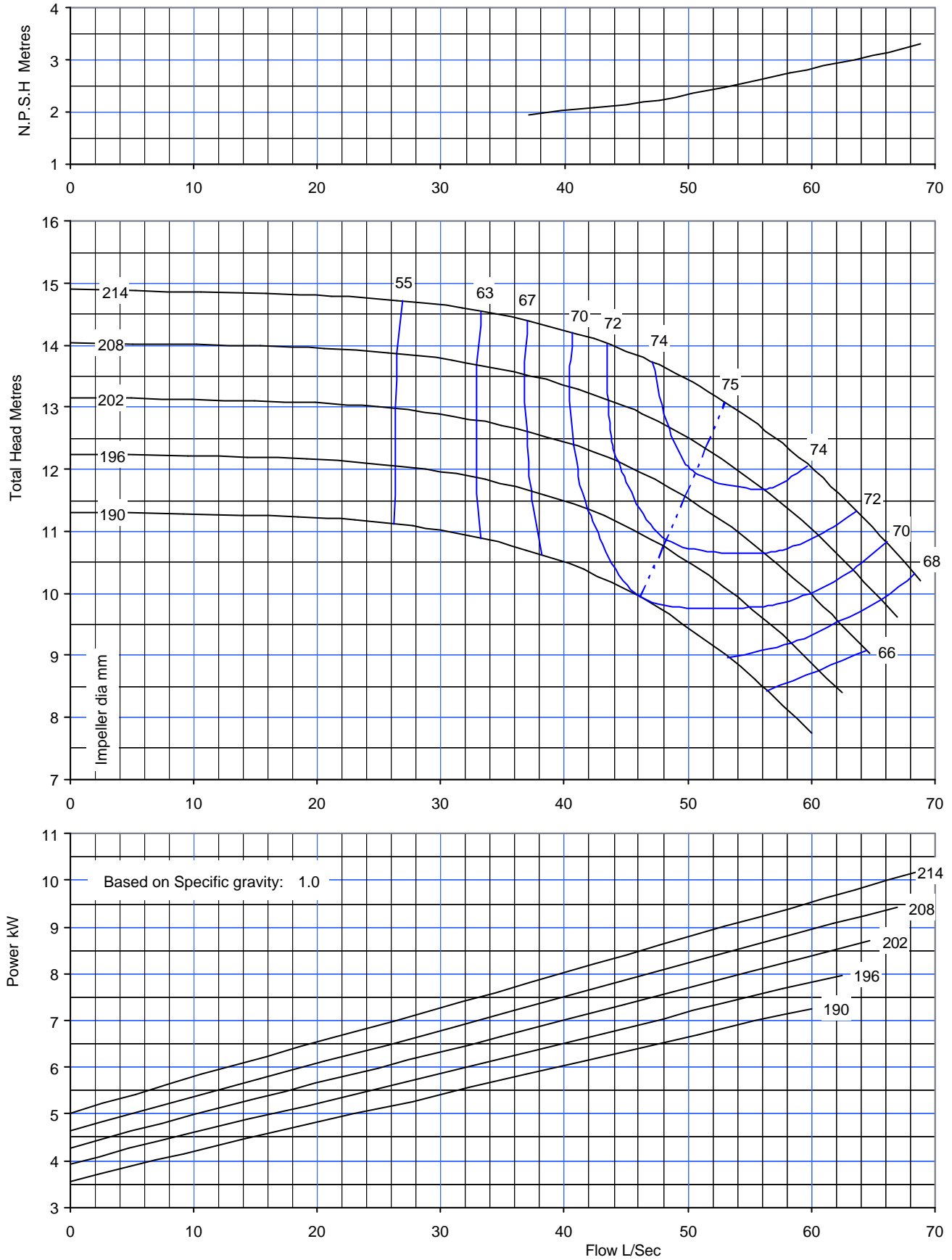

SUCTION DIA 150	DISCHARGE DIA 125	MAX PRESSURE 12 bar	PUMP MODEL TD 125-200	SPEED 1450
---------------------------	-----------------------------	-------------------------------	---------------------------------	----------------------

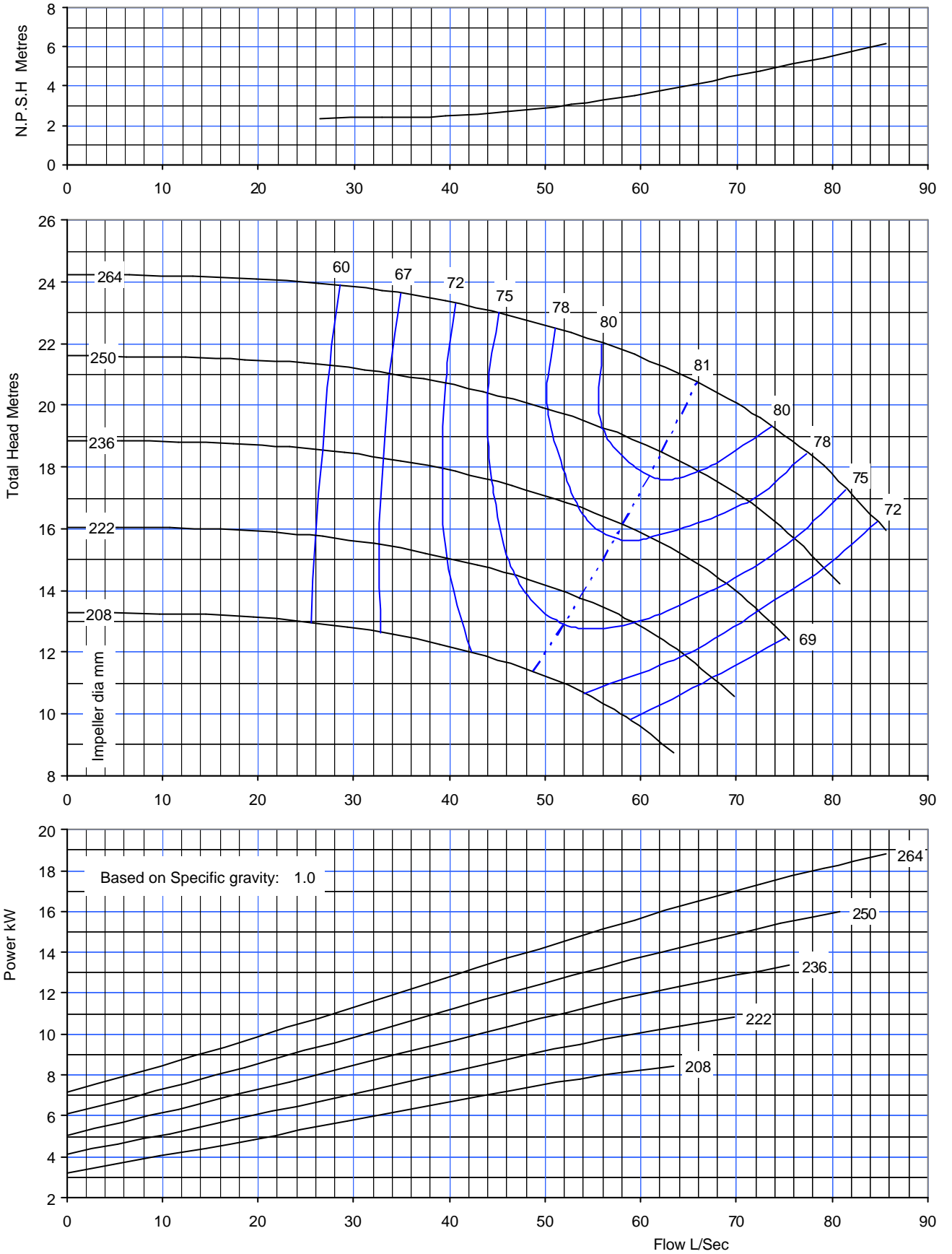

SUCTION DIA 150	DISCHARGE DIA 125	MAX PRESSURE 12 bar	PUMP MODEL TD 125-250	SPEED 1470
---------------------------	-----------------------------	-------------------------------	---------------------------------	----------------------

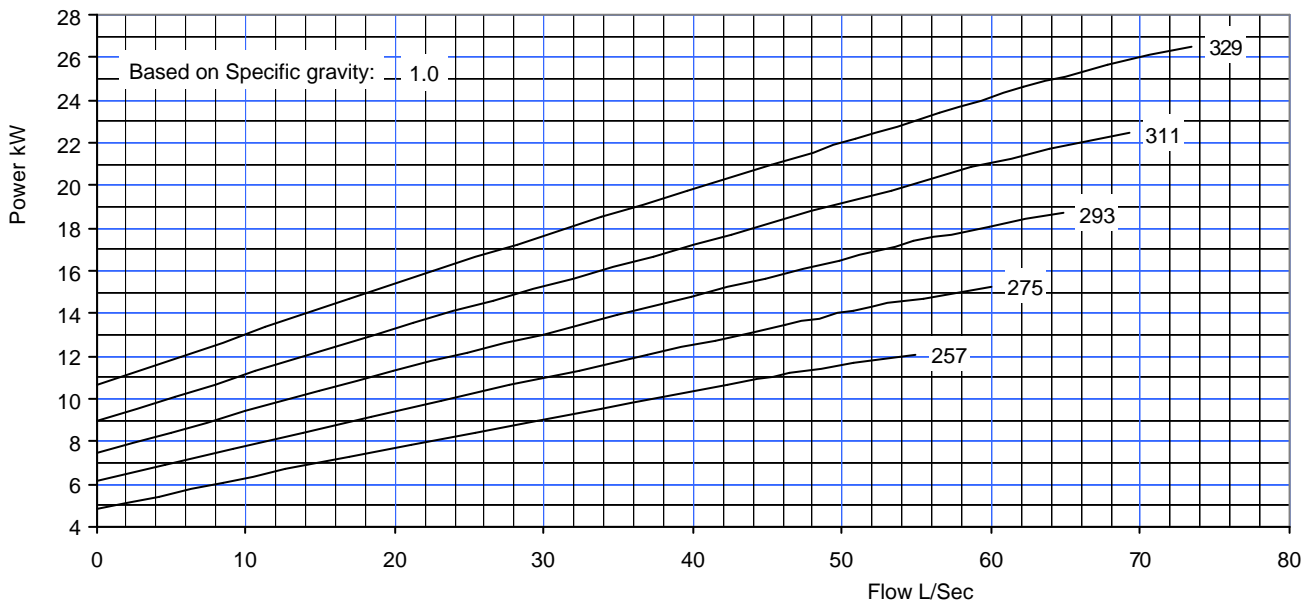
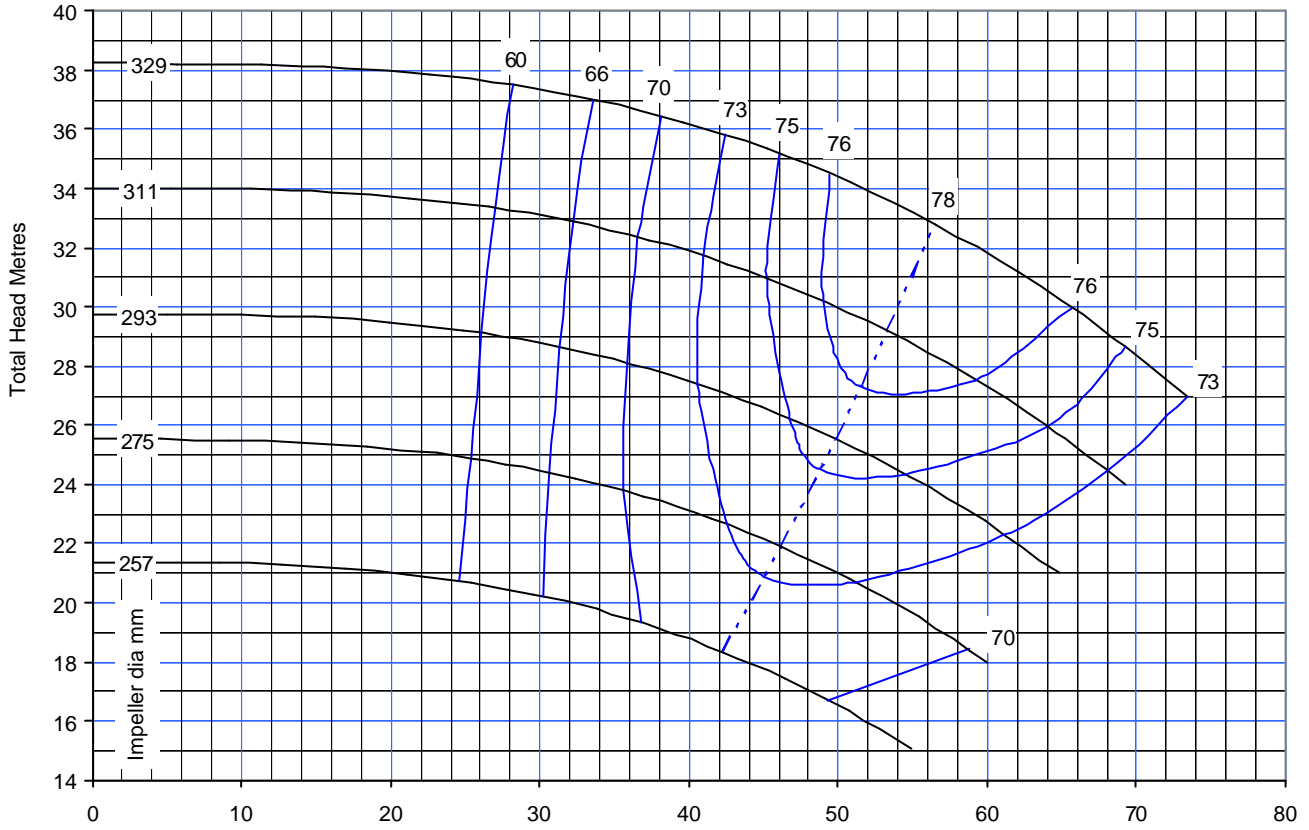
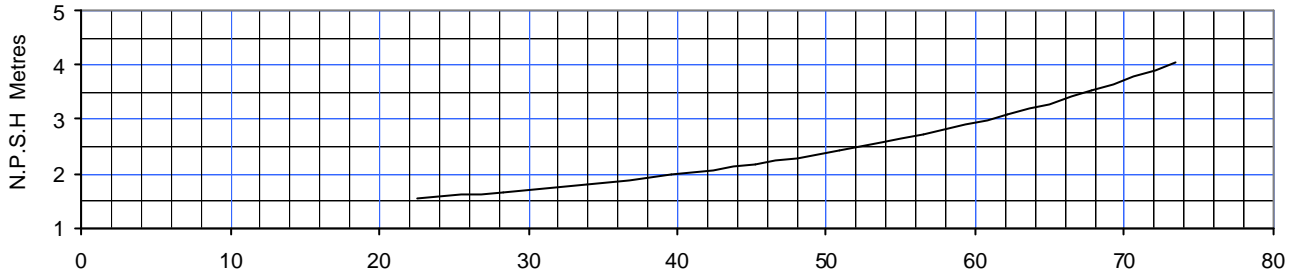

SUCTION DIA 150	DISCHARGE DIA 125	MAX PRESSURE 12 bar	PUMP MODEL TD 125-315	SPEED 1475
---------------------------	-----------------------------	-------------------------------	---------------------------------	----------------------

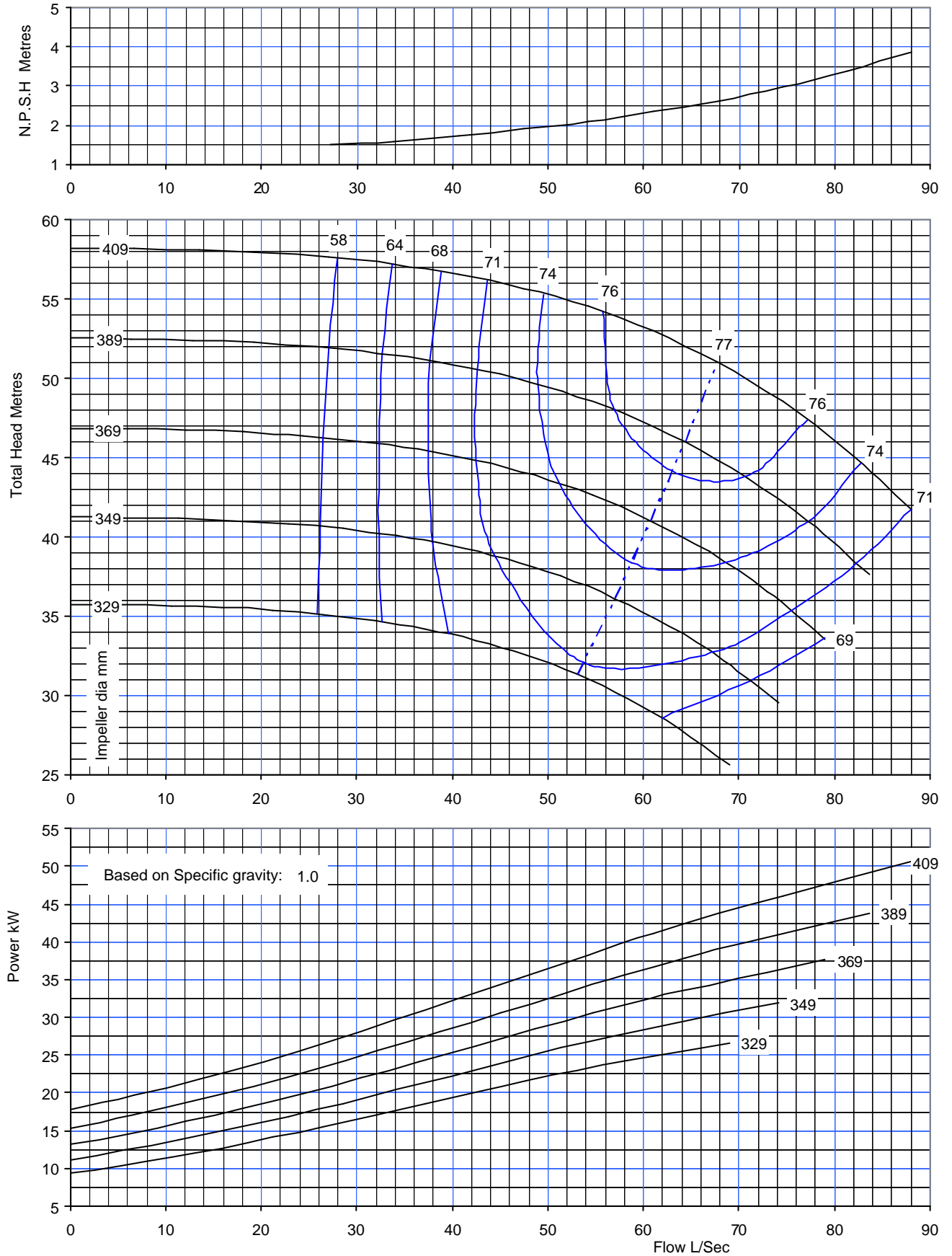

SUCTION DIA 150	DISCHARGE DIA 125	MAX PRESSURE 12 bar	PUMP MODEL TD 125-400	SPEED 1475
---------------------------	-----------------------------	-------------------------------	---------------------------------	----------------------

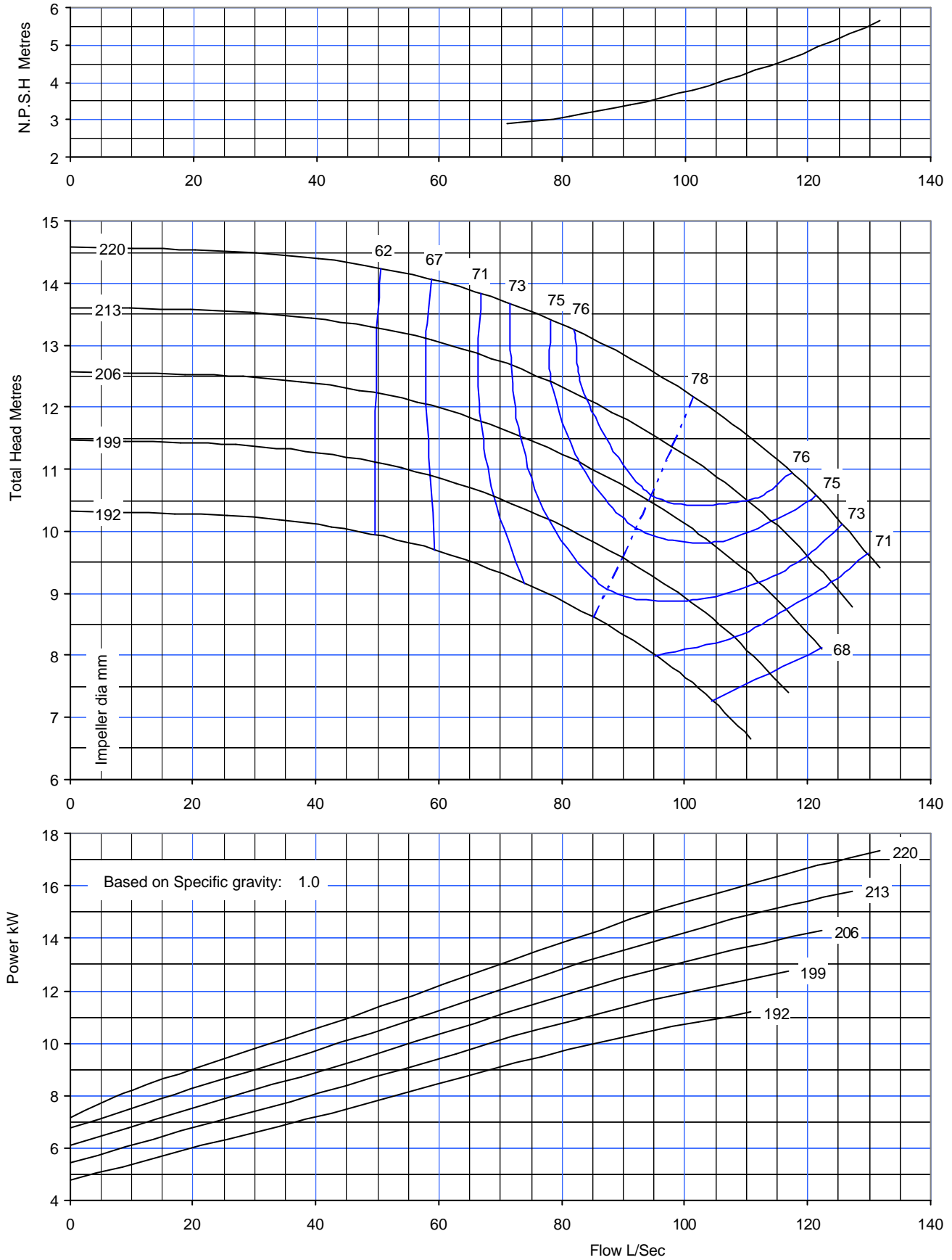

SUCTION DIA 200	DISCHARGE DIA 150	MAX PRESSURE 12 bar	PUMP MODEL TD 150-200	SPEED 1470
---------------------------	-----------------------------	-------------------------------	---------------------------------	----------------------

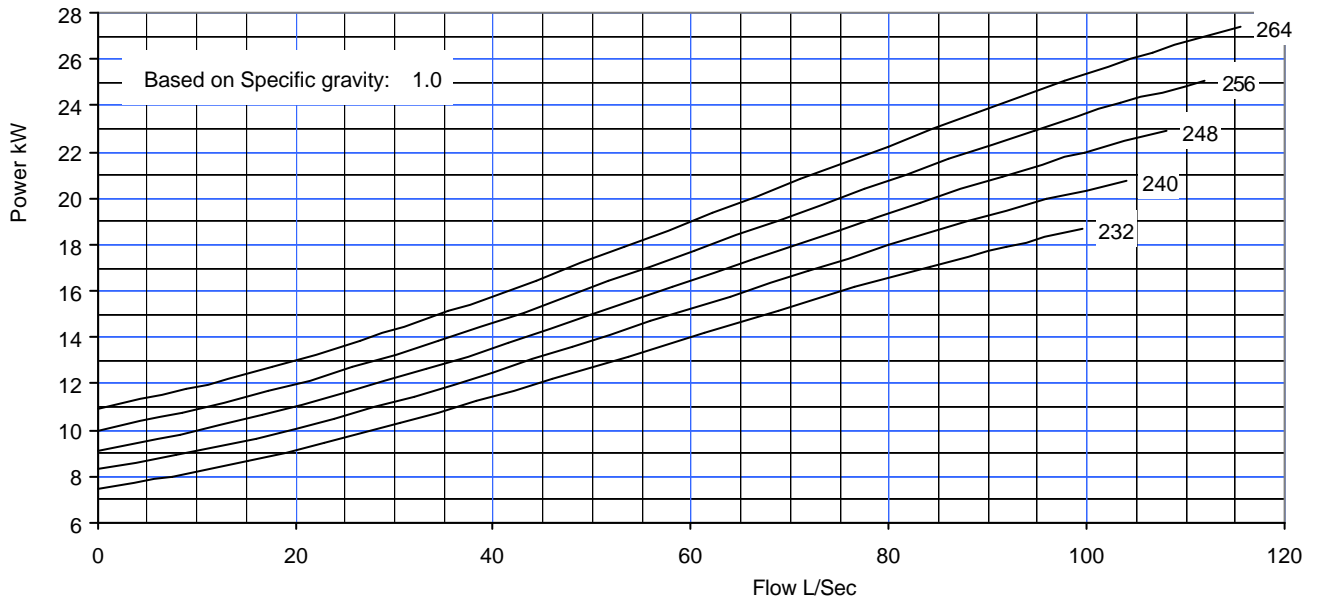
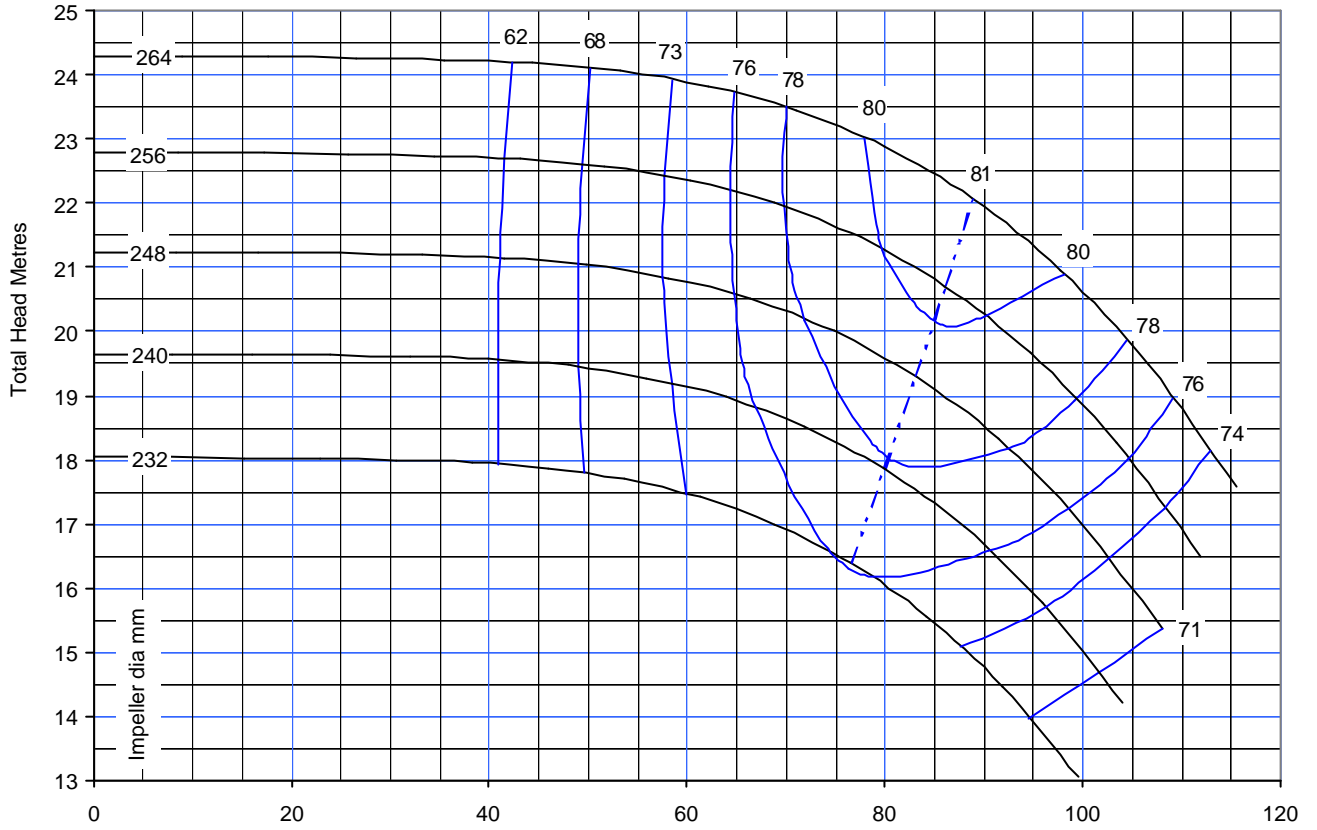
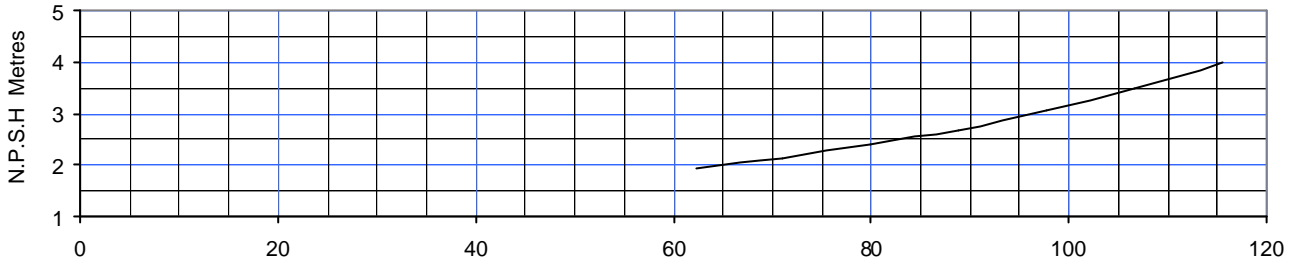

SUCTION DIA 200	DISCHARGE DIA 150	MAX PRESSURE 12 bar	PUMP MODEL TD 150-250	SPEED 1475
---------------------------	-----------------------------	-------------------------------	---------------------------------	----------------------

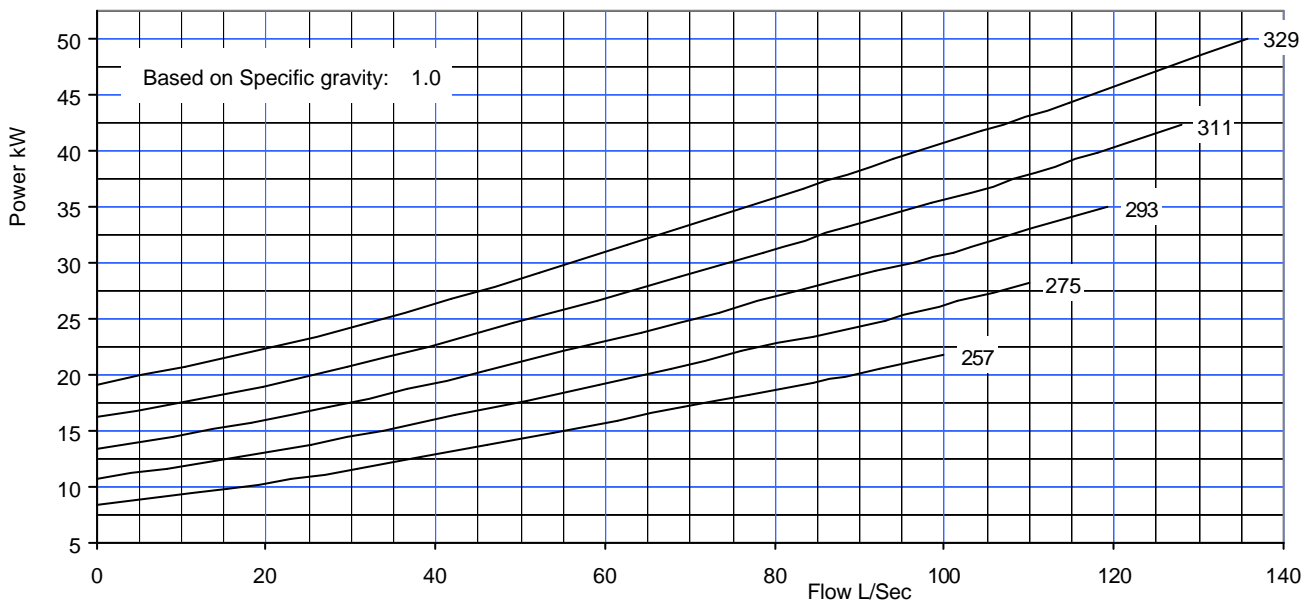
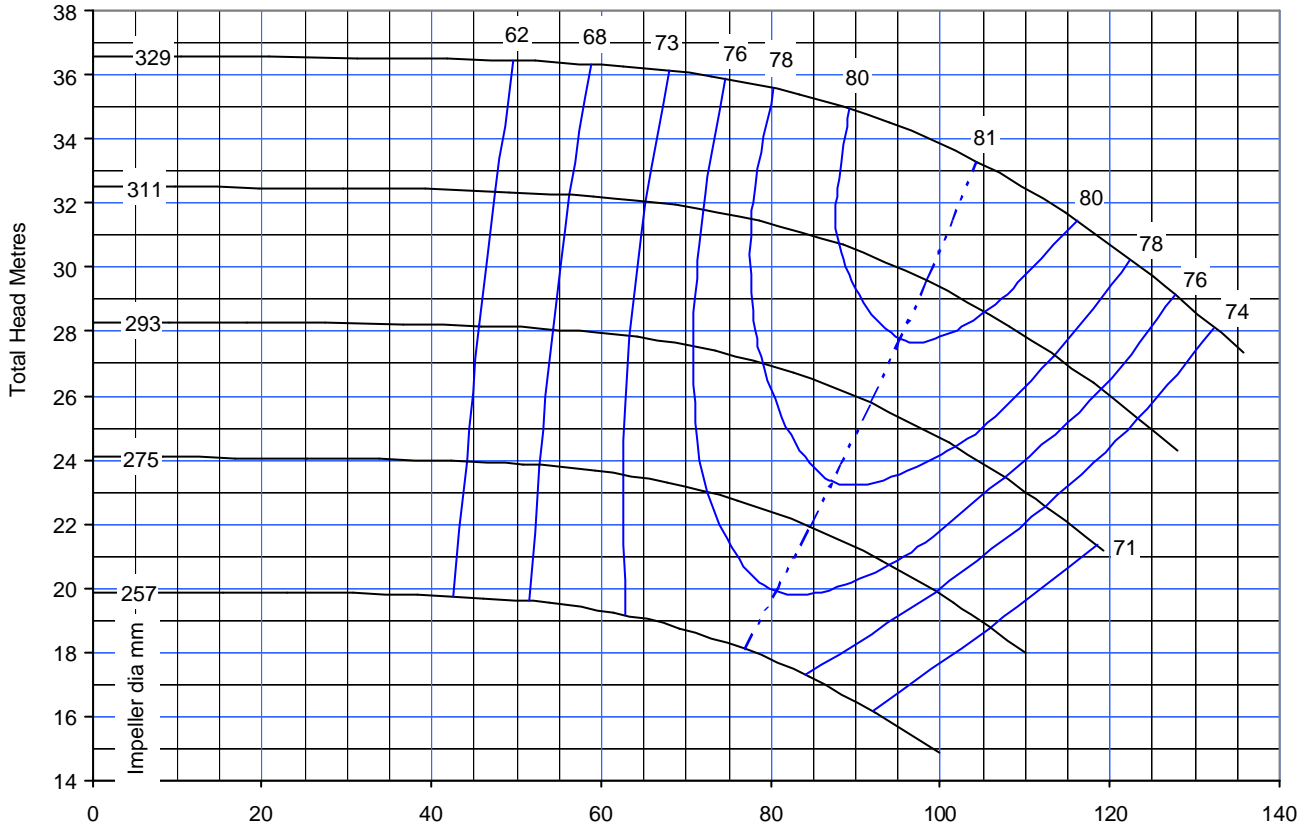
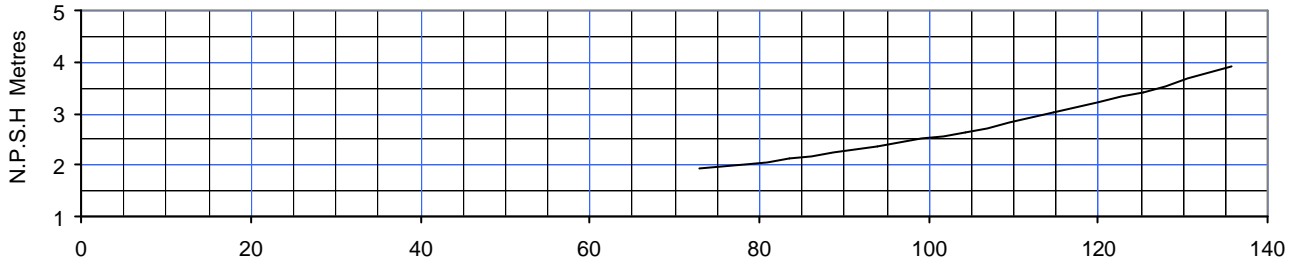

SUCTION DIA 200	DISCHARGE DIA 150	MAX PRESSURE 12 bar	PUMP MODEL TD 150-315	SPEED 1475
---------------------------	-----------------------------	-------------------------------	---------------------------------	----------------------

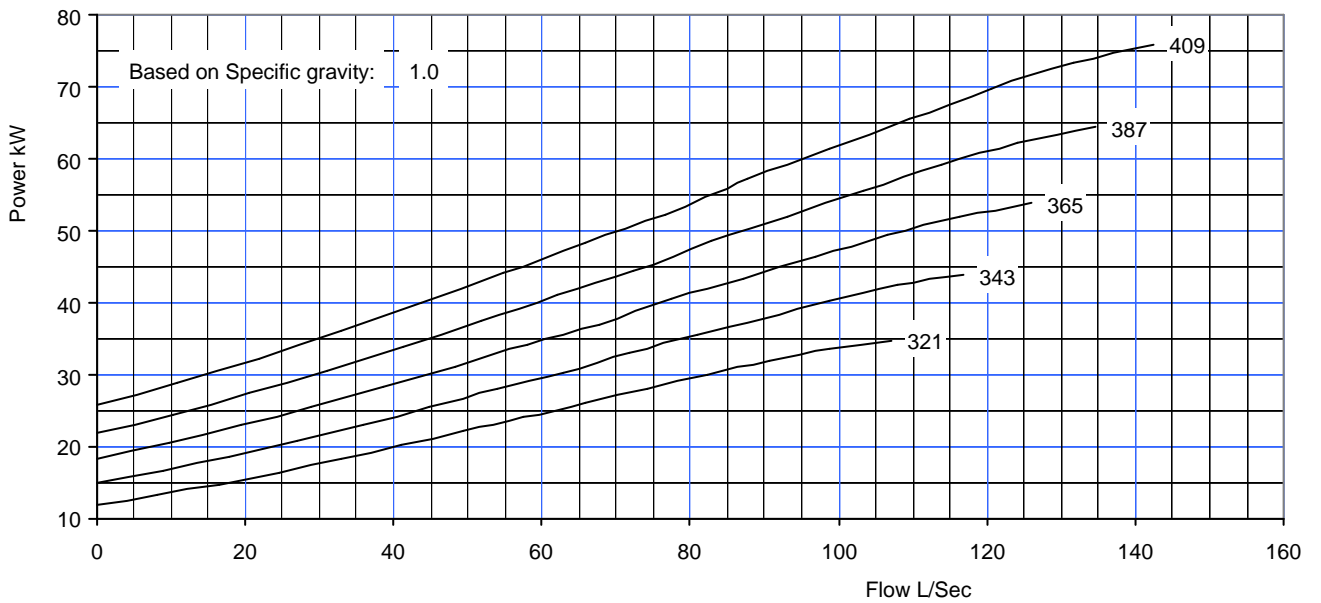
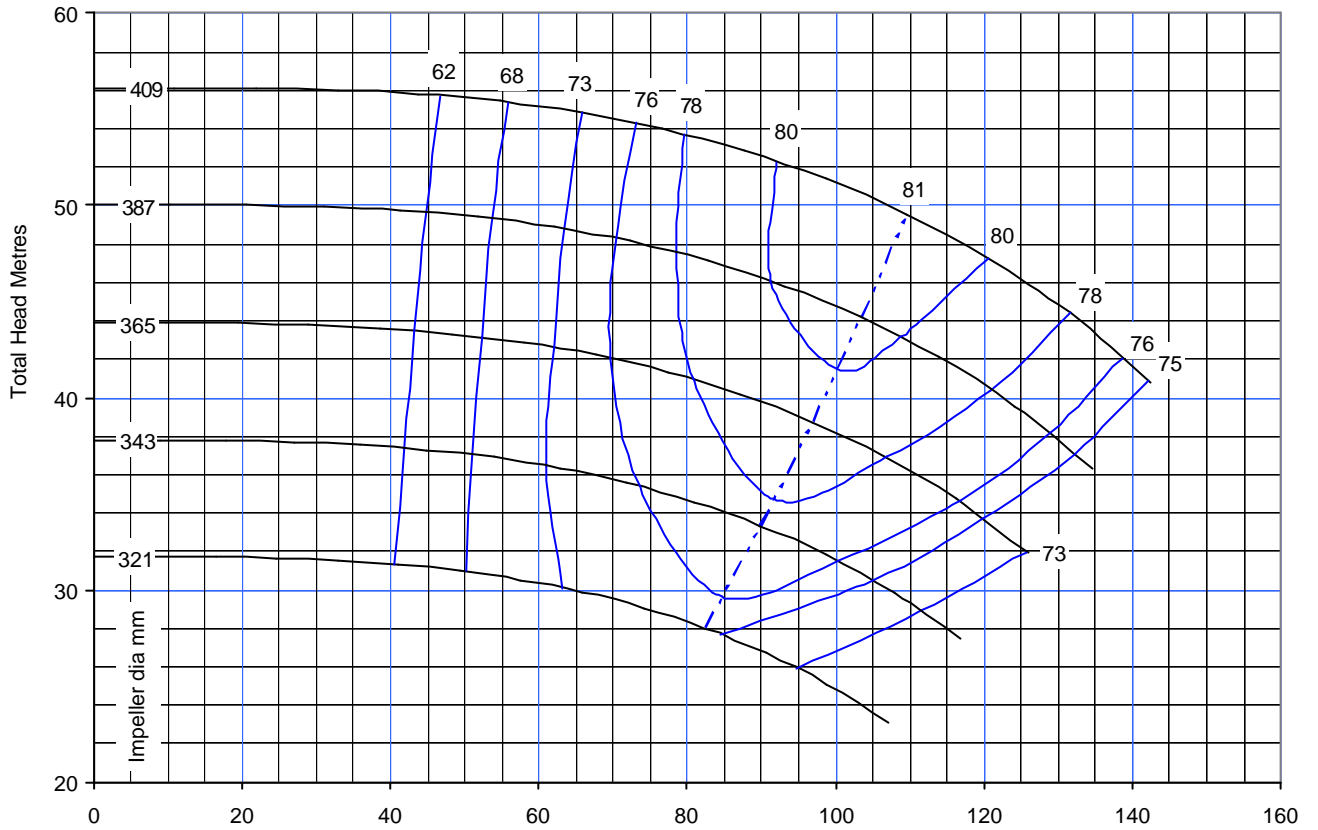
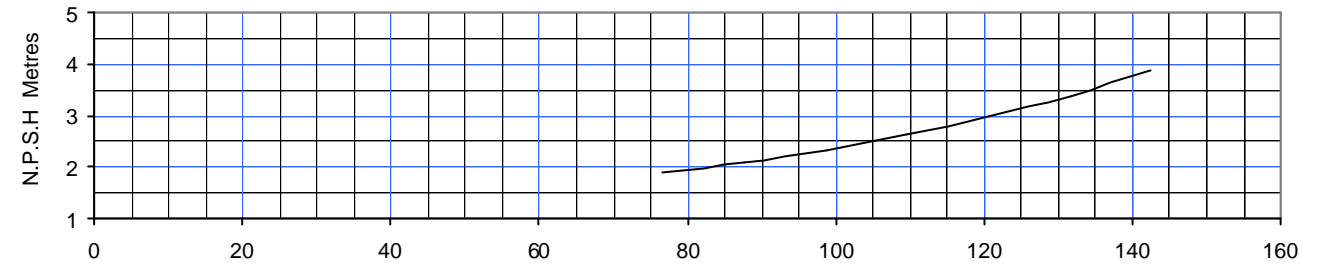

SUCTION DIA 200	DISCHARGE DIA 150	MAX PRESSURE 12 bar	PUMP MODEL TD 150-400	SPEED 1475
---------------------------	-----------------------------	-------------------------------	---------------------------------	----------------------

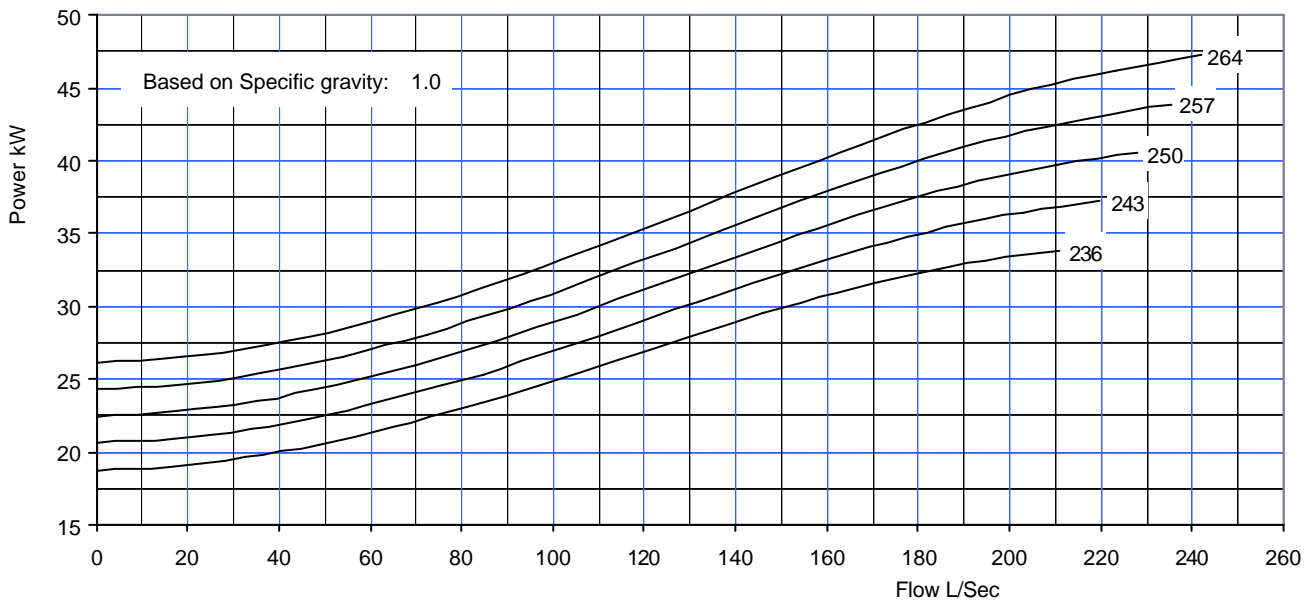
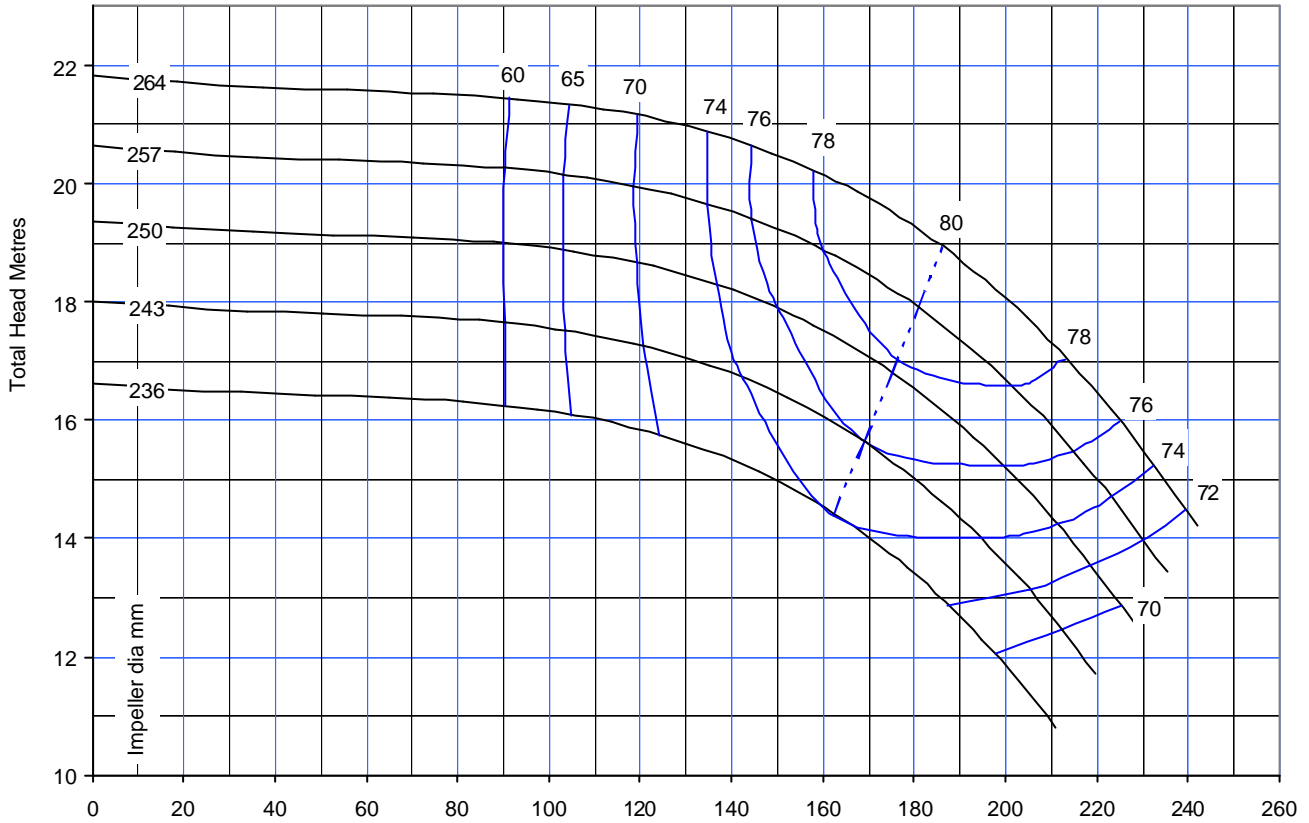
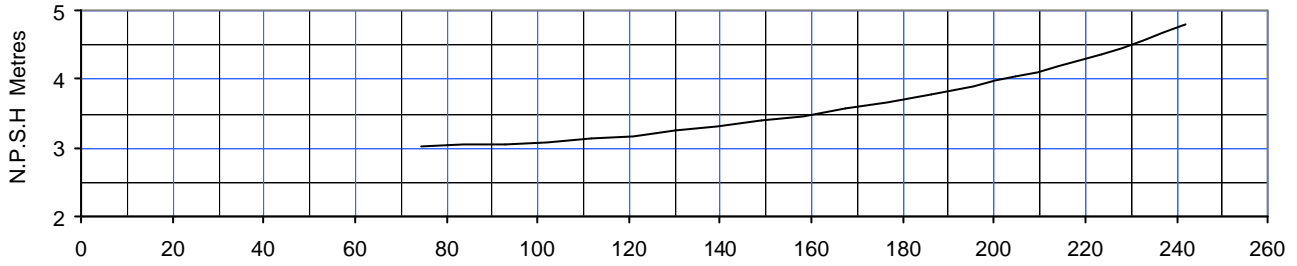

SUCTION DIA 250	DISCHARGE DIA 200	MAX PRESSURE 12 bar	PUMP MODEL TD 200-250	SPEED 1475
---------------------------	-----------------------------	-------------------------------	---------------------------------	----------------------

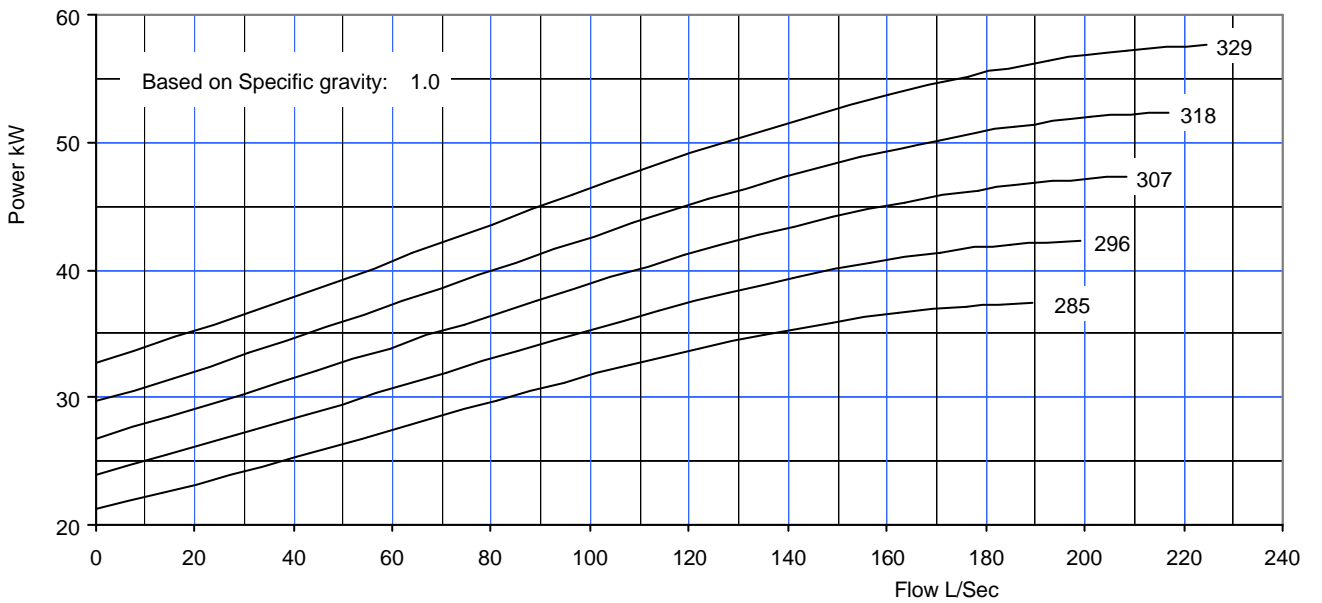
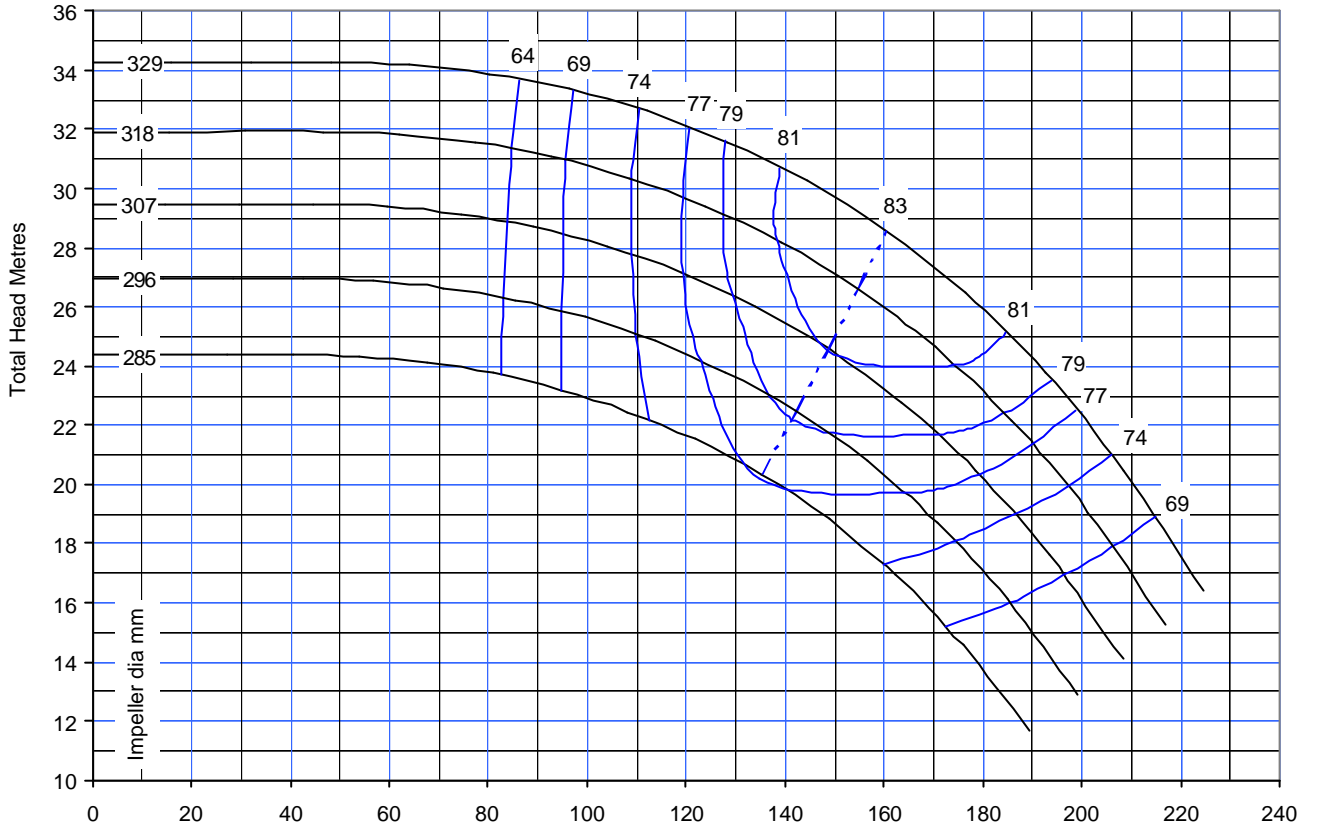
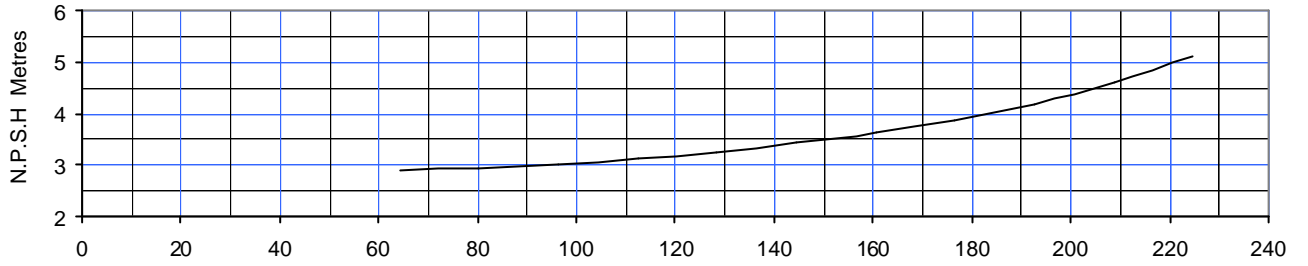

SUCTION DIA 250	DISCHARGE DIA 200	MAX PRESSURE 12 bar	PUMP MODEL TD 200-315	SPEED 1475
---------------------------	-----------------------------	-------------------------------	---------------------------------	----------------------

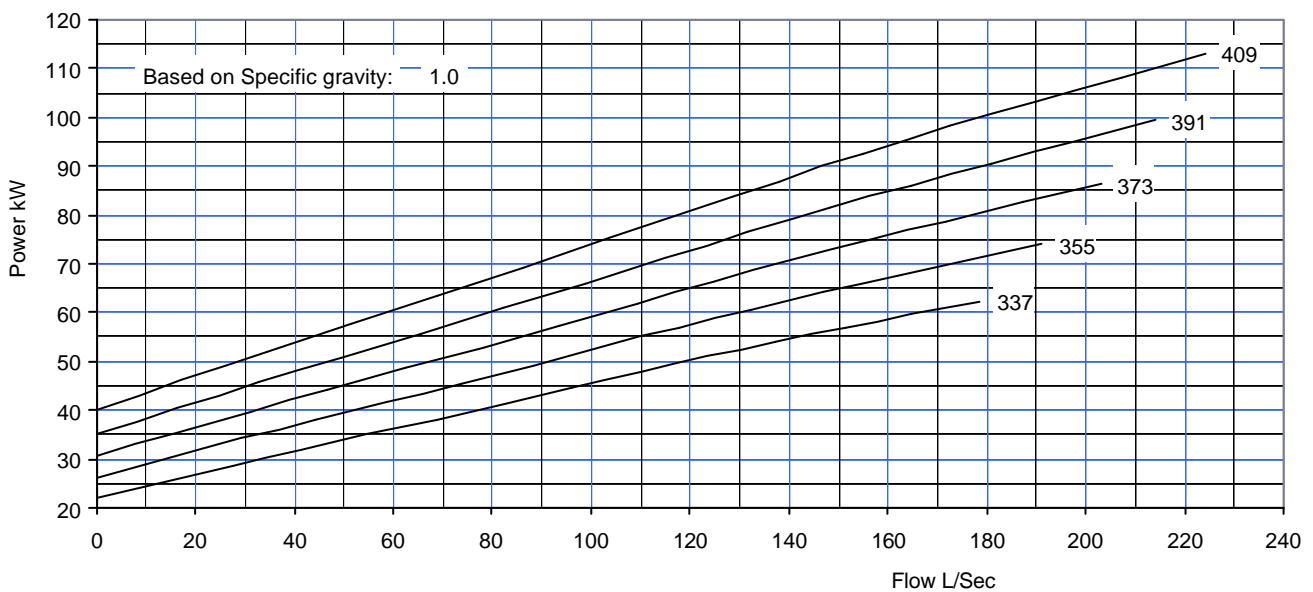
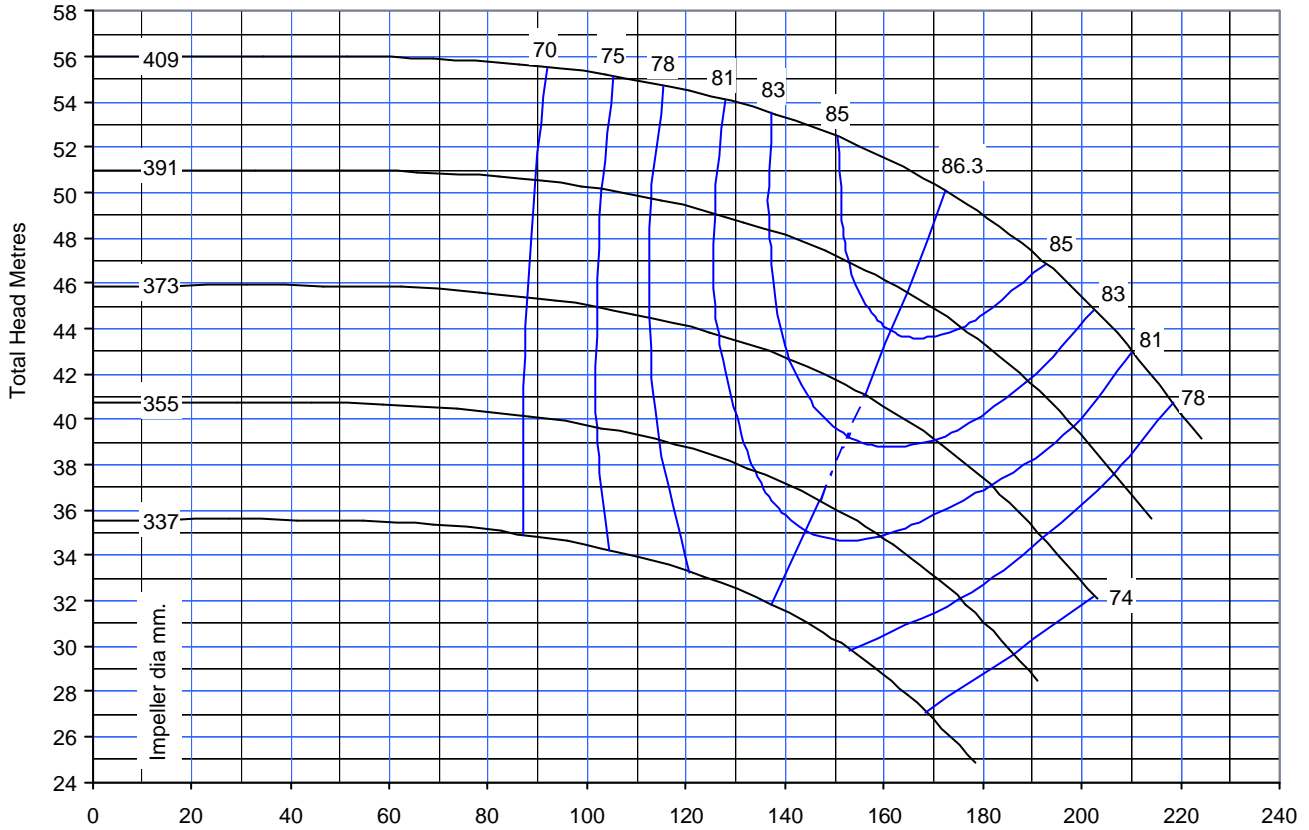
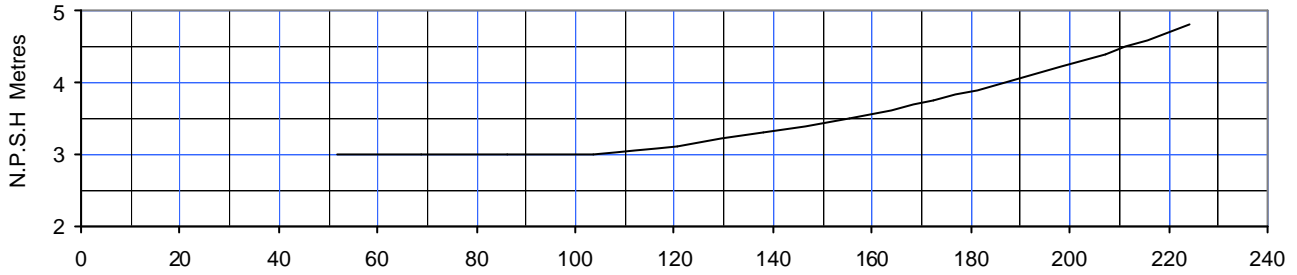

SUCTION DIA 250	DISCHARGE DIA 200	MAX PRESSURE 12 bar	PUMP MODEL TD 200-400	SPEED 1480
---------------------------	-----------------------------	-------------------------------	---------------------------------	----------------------

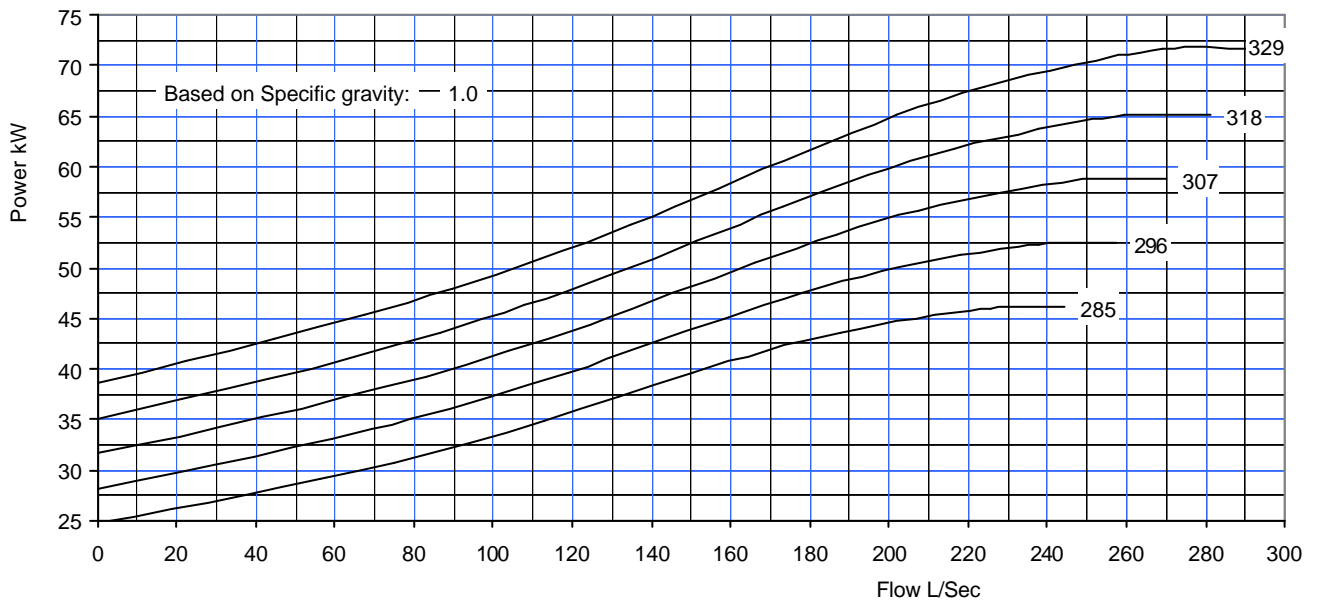
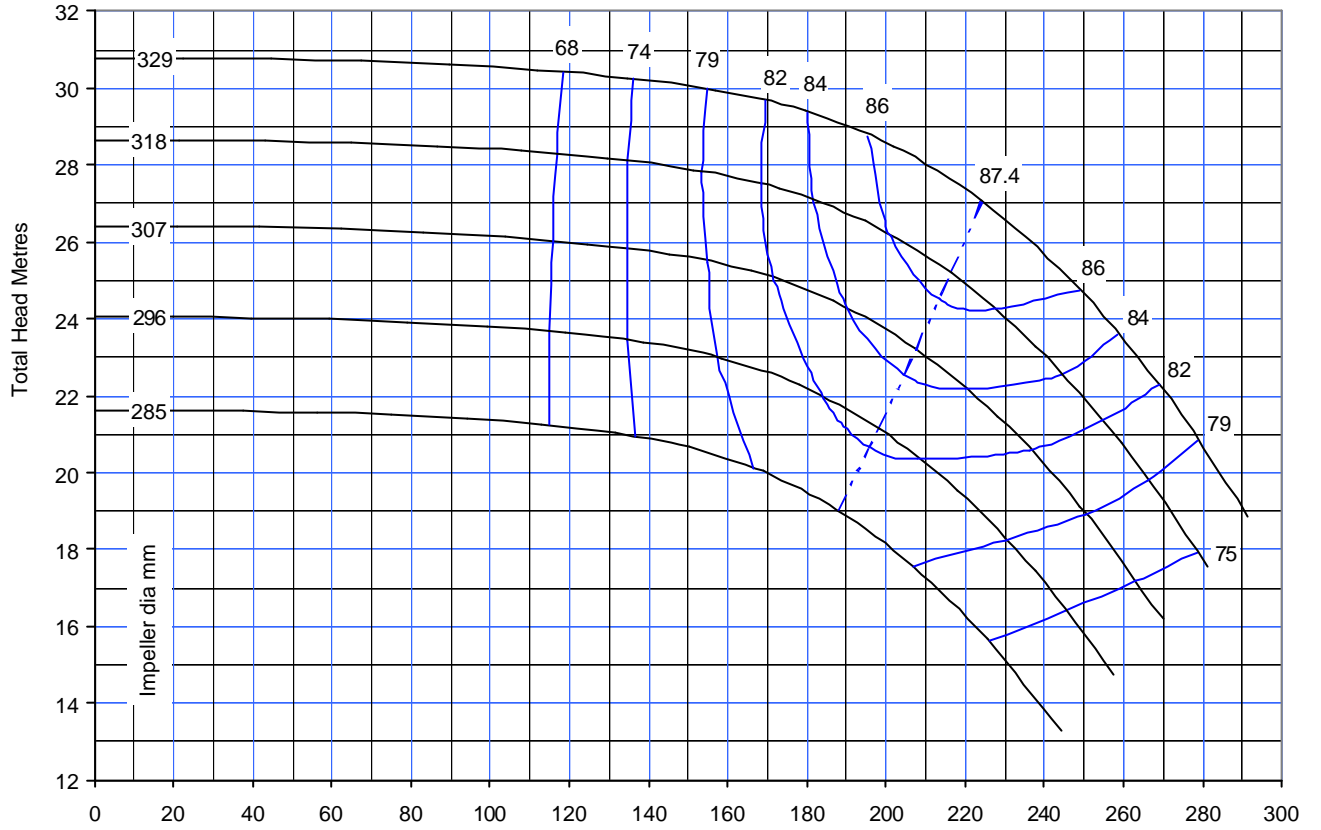
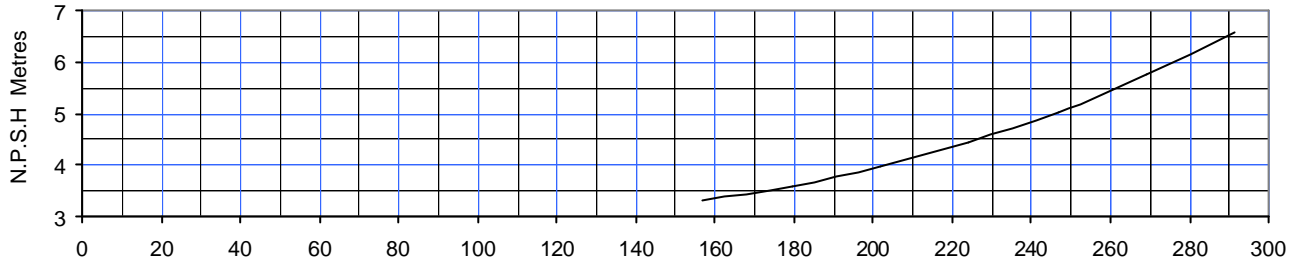

SUCTION DIA 300	DISCHARGE DIA 250	MAX PRESSURE 12 bar	PUMP MODEL TD 250-315	SPEED 1475
---------------------------	-----------------------------	-------------------------------	---------------------------------	----------------------

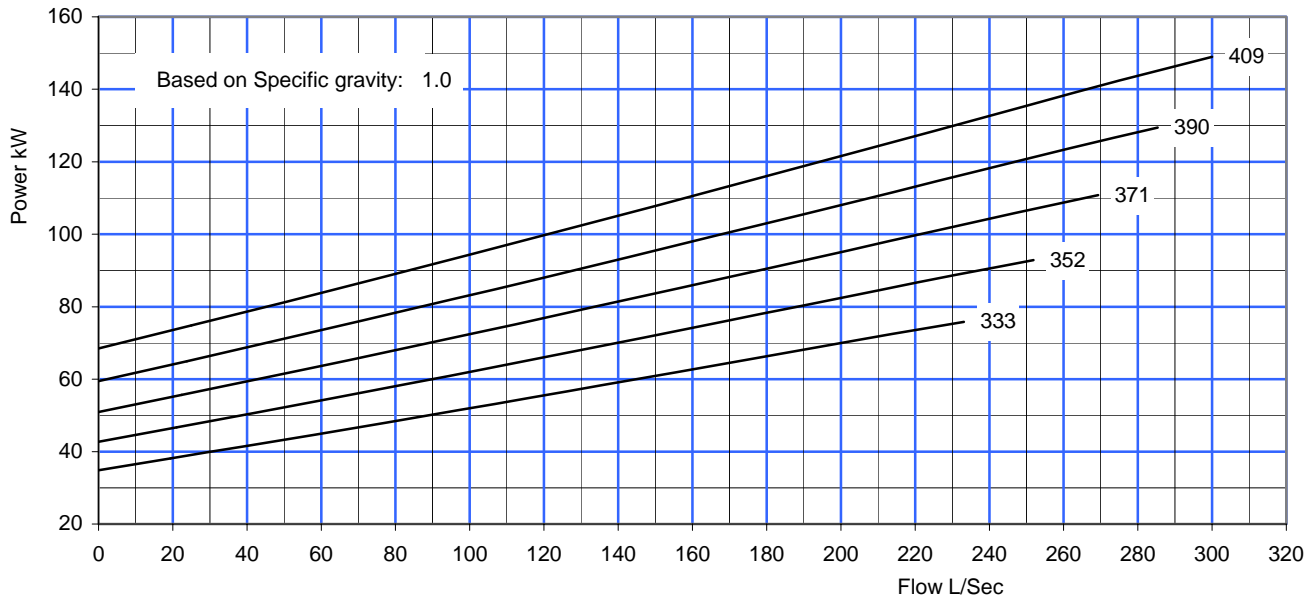
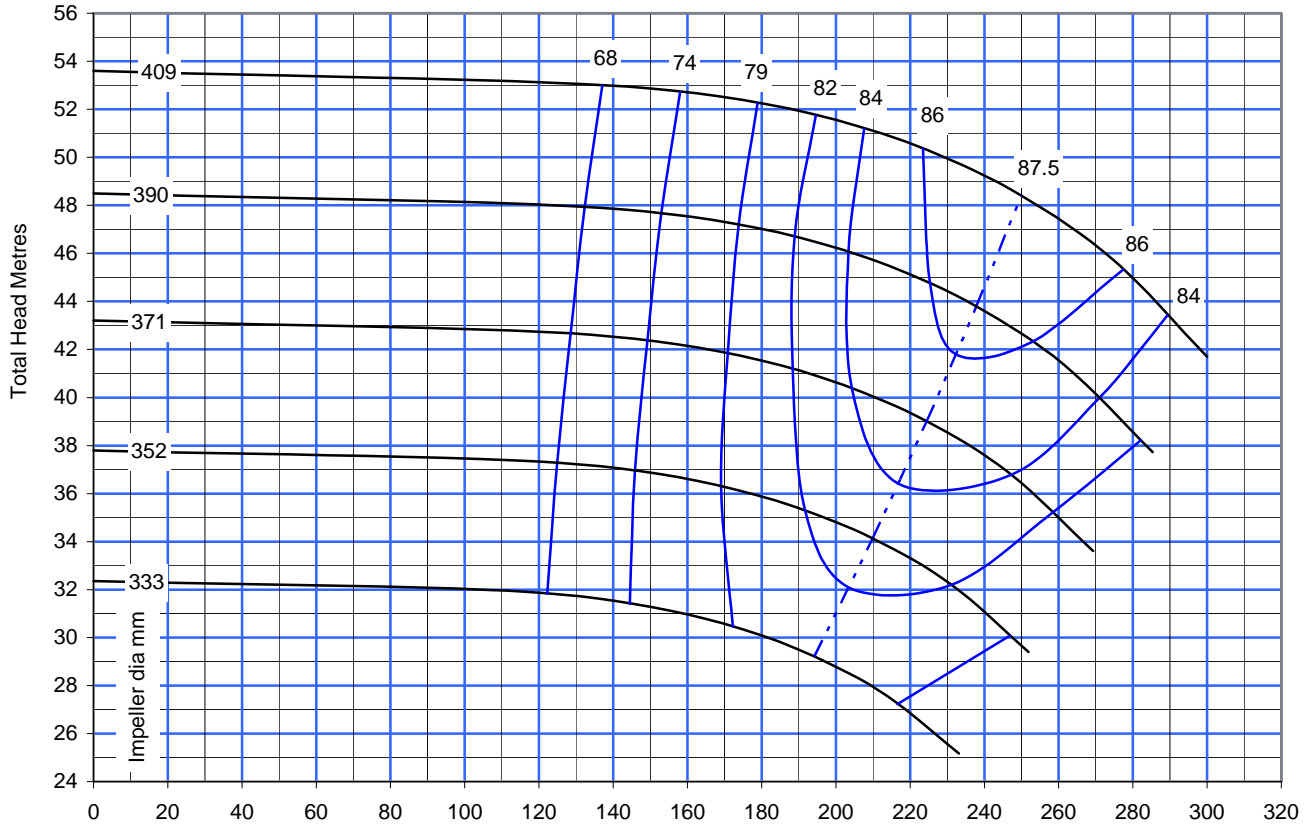
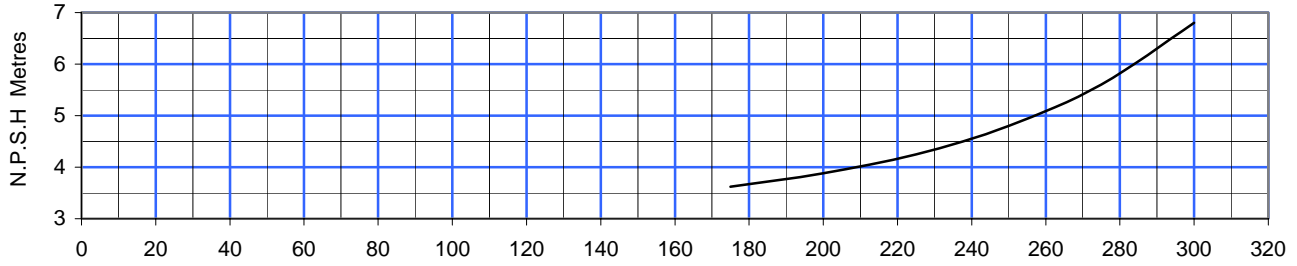

SUCTION DIA 300	DISCHARGE DIA 250	MAX PRESSURE 12 bar	PUMP MODEL TD 250-400	SPEED 1480
---------------------------	-----------------------------	-------------------------------	---------------------------------	----------------------

TD Bareshaft pump dimensions

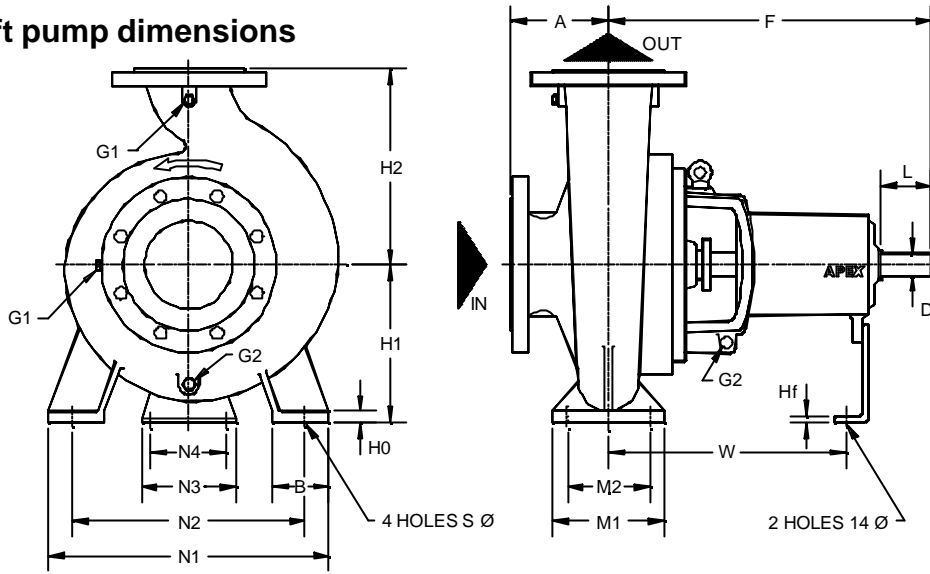

Pump size	Shaft group	Flanges		Outline Dimensions				Foot Dimensions						Rear Support Foot				Shaft		Tappings		Mass Kg	
		IN	OUT	A	F	H1	H2	N1	N2	M1	M2	B	S	H0	W	N3	N4	Hf	L	D	G1		G2
32-125	1	50	32	80	360	112	140	190	140	100	70	50	14	14	267	130	100	5	50	24	1/4	1/4	27
32-160	1	50	32	80	360	132	160	240	190	100	70	50	14	14	267	130	100	5	50	24	1/4	1/4	35
32-200	1	50	32	80	360	160	180	240	190	100	70	50	14	14	267	140	110	5	50	24	1/4	1/4	43
32-250	1	50	32	100	360	180	225	320	250	125	95	65	14	14	267	140	110	5	50	24	1/4	3/8	61
40-125	1	65	40	80	360	112	140	210	160	100	70	50	14	14	267	130	100	5	50	24	1/4	1/4	32
40-160	1	65	40	80	360	132	160	240	190	100	70	50	14	14	267	130	100	5	50	24	1/4	1/4	38
40-200	1	65	40	100	360	160	180	265	212	100	70	50	14	14	267	140	110	5	50	24	1/4	1/4	46
40-250	1	65	40	100	360	180	225	320	250	125	95	65	14	14	267	140	110	5	50	24	1/4	3/8	63
40-315	2	65	40	125	470	200	250	345	280	125	95	65	14	14	342	140	110	5	80	32	1/4	3/8	94
50-125	1	65	50	100	360	132	160	240	190	100	70	50	14	14	267	140	100	5	50	24	1/4	1/4	34
50-160	1	65	50	100	360	160	180	265	212	100	70	50	14	14	267	140	110	5	50	24	1/4	3/8	38
50-200	1	65	50	100	360	160	200	265	212	100	70	50	14	14	267	140	110	5	50	24	1/4	1/4	46
50-250	1	65	50	100	360	180	225	320	250	125	95	65	14	14	267	140	110	5	50	24	1/4	3/8	63
50-315	2	65	50	125	470	225	280	345	280	125	95	65	14	16	342	140	110	5	80	32	1/4	3/8	96
65-125	1	80	65	100	360	160	180	280	212	125	95	65	14	14	267	140	110	5	50	24	1/4	1/4	39
65-160	1	80	65	100	360	160	200	280	212	125	95	65	14	14	267	140	110	5	50	24	1/4	3/8	45
65-200	1	80	65	100	360	180	225	320	250	125	95	65	14	14	267	140	110	5	50	24	1/4	3/8	54
65-250	2	80	65	100	470	200	250	360	280	160	120	80	18	16	342	140	110	5	80	32	1/4	3/8	86
65-315	2	80	65	125	470	225	280	400	315	160	120	80	18	16	342	140	110	5	80	32	1/4	3/8	104
80-160	1	100	80	125	360	180	225	320	250	125	95	65	14	14	267	140	110	5	80	32	1/4	3/8	54
80-200	2	100	80	125	470	180	250	345	280	125	95	65	14	14	342	140	110	5	80	32	1/4	3/8	71
80-250	2	100	80	125	470	200	280	400	315	160	120	80	18	16	342	140	110	5	80	32	1/4	3/8	91
80-315	2	100	80	125	470	250	315	400	315	160	120	80	18	16	342	140	110	5	80	32	3/8	3/8	104
80-400	3	100	80	125	530	280	355	440	340	160	120	85	18	16	370	140	110	5	110	42	3/8	3/8	162
100-160	2	125	100	125	470	180	250*	360	280	160	120	80	18	16	342	140	110	5	80	32	1/4	3/8	81
100-200	2	125	100	125	470	200	280	360	280	160	120	80	18	16	342	140	110	5	80	32	1/4	3/8	88
100-250	2	125	100	140	470	225	280	400	315	160	120	80	18	16	342	140	110	5	80	32	3/8	3/8	110
100-315	2	125	100	140	470	250	315	400	315	160	120	80	18	16	342	140	110	5	80	32	3/8	3/8	120
100-400	3	125	100	140	530	280	355	500	400	200	150	100	23	18	370	140	110	5	110	42	3/8	3/8	122
125-200	2	150	125	140	470	250	315	400	315	160	120	80	18	16	342	140	110	5	80	32	3/8	3/8	98
125-250	2	150	125	140	470	250	355	400	315	160	120	80	18	16	342	140	110	5	80	32	3/8	3/8	115
125-315	3	150	125	140	530	280	355	500	400	200	150	100	23	18	370	140	110	5	110	42	3/8	3/8	155
125-400	3	150	125	140	530	315	400	500	400	200	150	100	23	18	370	140	110	5	110	42	3/8	3/8	189
150-200	2a	200	150	160	500	280	400	550	450	200	150	100	23	20	342	140	110	5	80	32	1/4	3/8	114
150-250	3	200	150	160	530	250	355	450	350	200	150	100	23	20	370	140	110	5	110	42	3/8	3/8	150
150-315	3	200	150	160	530	280	400	550	450	200	150	100	23	20	370	140	110	5	110	42	3/8	3/8	175
150-400	3	200	150	160	530	315	450	550	450	200	150	100	23	20	370	140	110	5	110	42	3/8	3/8	200
200-250	3	250	200	180	553	315	450	550	450	200	150	100	23	20	393	140	110	5	110	42	3/8	3/8	230
200-315	4	250	200	180	670	315	480	600	480	220	170	120	28	20	504	140	110	5	110	48	3/8	3/8	251
200-400	4	250	200	180	670	335	480	600	480	220	170	120	28	20	504	140	110	5	110	48	3/8	3/8	295
250-315	4	300	250	220	691	355	520	660	510	250	200	150	28	22	525	140	110	5	110	48	3/8	3/8	311
250-400	4	300	250	220	682	400	560	660	510	250	200	150	28	22	516	140	110	5	110	48	3/8	3/8	390

TD pumpset dimensions

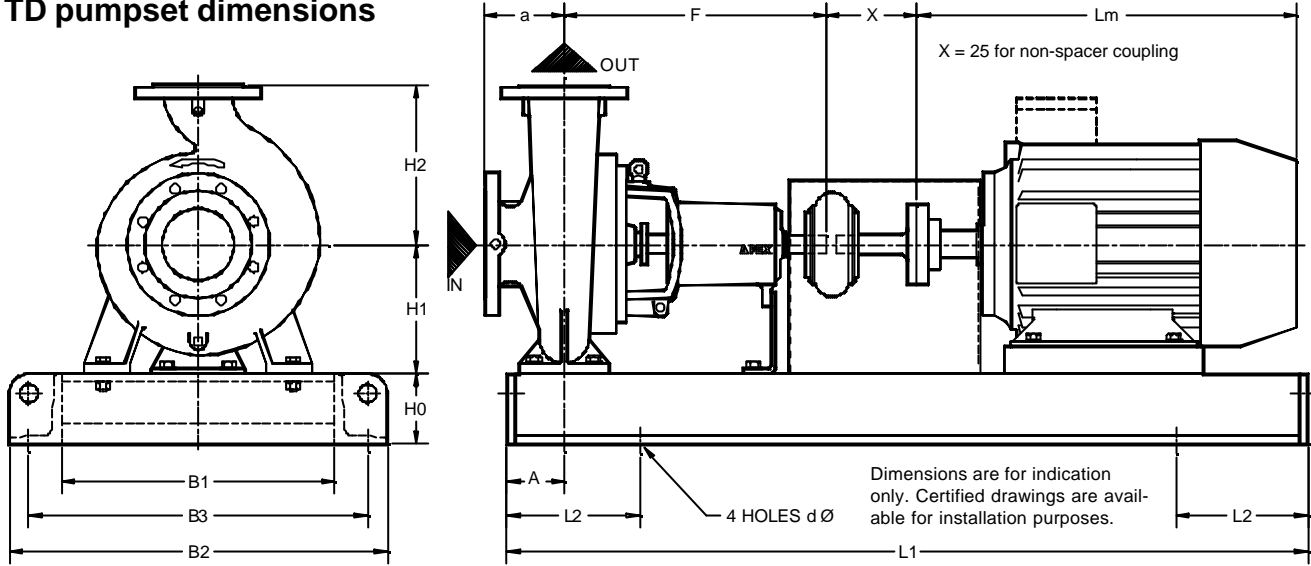

Pump & Motor			Pump dimensions						Bedplate dimensions								dB	Kg			
TD Pump	1450 rpm	2900 rpm	In	Out	a	F	H1	H2	Bed ref	H0	A	L1	L2	B1	B2	B3			d	X	Lm
32-125	0.55	50	32	80	360	112	140	2a	75	60	800	130	260	360	320	18	100	269	55	74	
		0.75	50	32	80	360	112	140	2a	75	60	800	130	260	360	320	18	100	269	65	74
		1.1	50	32	80	360	112	140	2a	75	60	800	130	260	360	320	18	100	269	65	74
		1.5	50	32	80	360	112	140	2a	75	60	800	130	260	360	320	18	100	294	68	76
		2.2	50	32	80	360	112	140	2a	75	60	800	130	260	360	320	18	100	294	68	90
32-160	0.55	50	32	80	360	132	160	2a	75	60	800	130	260	360	320	18	100	269	55	82	
		1.5	50	32	80	360	132	160	2a	75	60	800	130	260	360	320	18	100	294	68	84
		2.2	50	32	80	360	132	160	2a	75	60	800	130	260	360	320	18	100	294	68	96
		3.0	50	32	80	360	132	160	3a	75	60	900	150	290	390	350	18	100	365	65	109
		4.0	50	32	80	360	132	160	3a	75	60	900	150	290	390	350	18	100	365	68	112
32-200	0.55	50	32	80	360	160	180	2a	75	60	800	130	260	360	320	18	100	269	55	90	
		0.75	50	32	80	360	160	180	2a	75	60	800	130	260	360	320	18	100	269	55	90
		1.1	50	32	80	360	160	180	2a	75	60	800	130	260	360	320	18	100	294	57	92
	4.0	50	32	80	360	160	180	3a	75	60	900	150	290	390	350	18	100	365	68	120	
		5.5	50	32	80	360	160	180	4a	75	60	1000	170	350	450	400	22	100	450	74	146
		7.5	50	32	80	360	160	180	4a	75	60	1000	170	350	450	400	22	100	450	74	146
32-250	1.1	50	32	100	360	180	225	4b	75	75	1000	170	350	450	400	22	100	294	57	129	
		1.5	50	32	100	360	180	225	4b	75	75	1000	170	350	450	400	22	100	294	57	131
		2.2	50	32	100	360	180	225	4b	75	75	1000	170	350	450	400	22	100	365	58	142
	11.0	50	32	100	360	180	225	5b	100	75	1120	190	360	490	450	22	100	594	77	218	
		15.0	50	32	100	360	180	225	5b	100	75	1120	190	360	490	450	22	100	594	77	218
		18.5	50	32	100	360	180	225	5b	100	75	1120	190	360	490	450	22	100	594	77	232
40-125	0.55	65	40	80	360	112	140	2a	75	60	800	130	260	360	320	18	100	269	55	79	
		1.5	65	40	80	360	112	140	2a	75	60	800	130	260	360	320	18	100	294	68	81
		2.2	65	40	80	360	112	140	2a	75	60	800	130	260	360	320	18	100	294	68	95
		3.0	65	40	80	360	112	140	3a	75	60	900	150	290	390	350	18	100	365	65	106
		4.0	65	40	80	360	112	140	3a	75	60	900	150	290	390	350	18	100	365	68	109
40-160	0.55	65	40	80	360	132	160	2a	75	60	800	130	260	360	320	18	100	269	55	85	
		0.75	65	40	80	360	132	160	2a	75	60	800	130	260	360	320	18	100	269	55	85
		1.1	65	40	80	360	132	160	2a	75	60	800	130	260	360	320	18	100	294	57	77
	3.0	65	40	80	360	132	160	3a	75	60	900	150	290	390	350	18	100	365	65	90	
		4.0	65	40	80	360	132	160	3a	75	60	900	150	290	390	350	18	100	365	68	94
		5.5	65	40	80	360	132	160	4a	75	60	1000	170	350	450	400	22	100	450	74	115
		7.5	65	40	80	360	132	160	4a	75	60	1000	170	350	450	400	22	100	450	74	115
40-200	0.75	65	40	100	360	160	180	3a	75	60	900	150	290	390	350	18	100	269	55	84	
		1.1	65	40	100	360	160	180	3a	75	60	900	150	290	390	350	18	100	294	57	87
		1.5	65	40	100	360	160	180	3a	75	60	900	150	290	390	350	18	100	294	57	88
	5.5	65	40	100	360	160	180	4a	75	60	1000	170	350	450	400	22	100	450	74	123	
		7.5	65	40	100	360	160	180	4a	75	60	1000	170	350	450	400	22	100	450	74	123
		11	65	40	100	360	160	180	5a	100	60	1120	190	360	490	440	22	100	594	77	175
40-250	1.5	65	40	100	360	180	225	4b	75	75	1000	170	350	450	400	22	100	294	57	120	
		2.2	65	40	100	360	180	225	4b	75	75	1000	170	350	450	400	22	100	365	58	130
		3.0	65	40	100	360	180	225	4b	75	75	1000	170	350	450	400	22	100	365	58	130
	11	65	40	100	360	180	225	5b	100	75	1120	190	360	490	440	22	100	594	77	203	
		15	65	40	100	360	180	225	5b	100	75	1120	190	360	490	440	22	100	594	77	203
		18.5	65	40	100	360	180	225	5b	100	75	1120	190	360	490	440	22	100	594	77	217
		22	65	40	100	360	180	225	5b	100	75	1120	190	360	490	440	22	100	594	77	230

TD pumpset dimensions

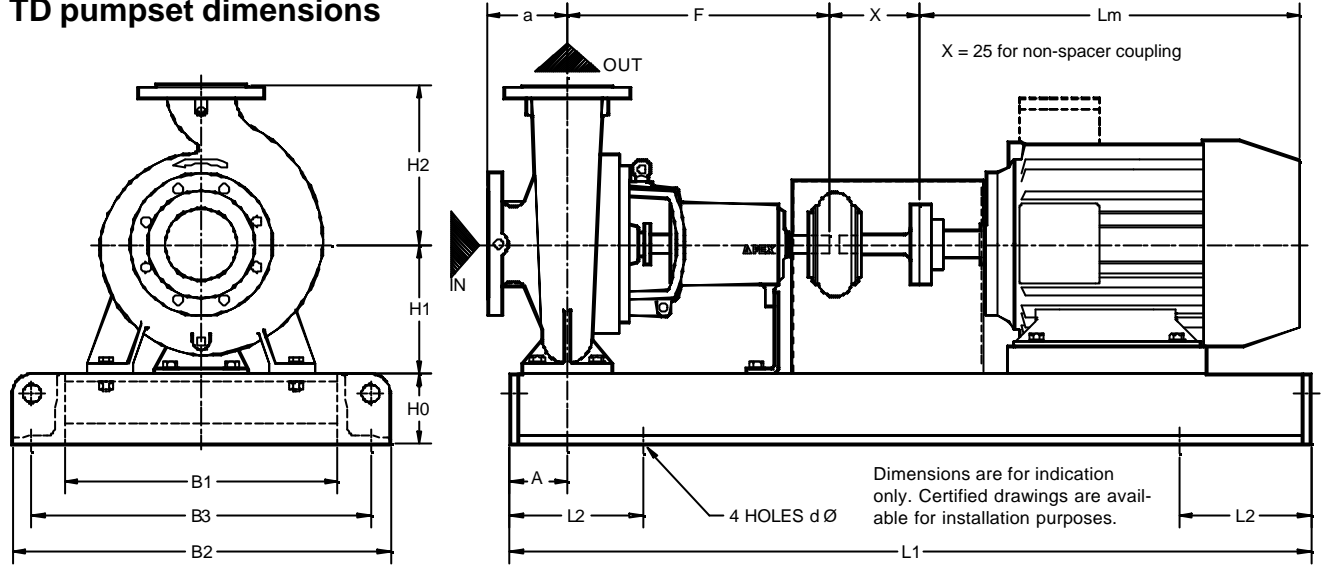

Pump & motor			Pump dimensions					Bedplate dimensions														
TD Pump	1450 rpm	2900 rpm	In	Out	a	F	H1	H2	Bed ref	H0	A	L1	L2	B1	B2	B3	d	X	Lm	dB	kg	
40-315	2.2		65	40	125	470	200	250	5b	100	75	1120	190	360	490	440	22	140	365	58	179	
	3.0		65	40	125	470	200	250	5b	100	75	1120	190	360	490	440	22	140	365	58	179	
	4.0		65	40	125	470	200	250	5b	100	75	1120	190	360	490	440	22	140	365	59	183	
	5.5		65	40	125	470	200	250	5b	100	75	1120	190	360	490	440	22	140	450	67	199	
		18.5		65	40	125	470	200	250	6b	100	75	1250	205	410	540	490	22	140	594	77	255
		22		65	40	125	470	200	250	6b	100	75	1250	205	410	540	490	22	140	594	77	268
		30		65	40	125	470	200	250	7b	100	75	1400	230	480	610	550	25	140	784	86	370
		37		65	40	125	470	200	250	7b	100	75	1400	230	480	610	550	25	140	784	86	370
	50-125	0.55		65	50	100	360	132	160	2a	75	60	800	130	260	360	320	18	100	269	55	70
		0.75		65	50	100	360	132	160	2a	75	60	800	130	260	360	320	18	100	269	55	70
1.1			65	50	100	360	132	160	2a	75	60	800	130	260	360	320	18	100	294	57	73	
		3.0		65	50	100	360	132	160	3a	75	60	900	150	290	390	350	18	100	365	65	86
		4.0		65	50	100	360	132	160	3a	75	60	900	150	290	390	350	18	100	365	68	90
		5.5		65	50	100	360	132	160	3a	75	60	900	150	290	390	350	18	100	450	74	106
		7.5		65	50	100	360	132	160	3a	75	60	900	150	290	390	350	18	100	450	74	106
50-160	0.75		65	50	100	360	160	180	3a	75	60	900	150	290	390	350	18	100	269	55	76	
	1.1		65	50	100	360	160	180	3a	75	60	900	150	290	390	350	18	100	294	57	79	
	1.5		65	50	100	360	160	180	3a	75	60	900	150	290	390	350	18	100	294	57	80	
		5.5		65	50	100	360	160	180	4a	75	60	1000	170	350	450	400	22	100	450	74	115
		7.5		65	50	100	360	160	180	4a	75	60	1000	170	350	450	400	22	100	450	74	115
		11		65	50	100	360	160	180	5a	100	60	1120	190	360	490	440	22	100	594	77	167
50-200	1.1		65	50	100	360	160	200	3a	75	60	900	150	290	390	350	18	100	294	57	87	
	1.5		65	50	100	360	160	200	3a	75	60	900	150	290	390	350	18	100	294	57	88	
	2.2		65	50	100	360	160	200	3a	75	60	900	150	290	390	350	18	100	365	58	98	
		7.5		65	50	100	360	160	200	4a	75	60	1000	170	350	450	400	22	100	450	74	123
		11		65	50	100	360	160	200	5a	100	60	1120	190	360	490	440	22	100	594	77	175
		15		65	50	100	360	160	200	5a	100	60	1120	190	360	490	440	22	100	594	77	175
		18.5		65	50	100	360	160	200	5a	100	60	1120	190	360	490	440	22	100	594	77	189
	50-250	2.2		65	50	100	360	180	225	4b	75	75	1000	170	350	450	400	22	100	365	58	130
3.0			65	50	100	360	180	225	4b	75	75	1000	170	350	450	400	22	100	365	58	130	
4.0			65	50	100	360	180	225	4b	75	75	1000	170	350	450	400	22	100	365	59	134	
5.5			65	50	100	360	180	225	4b	75	75	1000	170	350	450	400	22	100	450	67	150	
		15		65	50	100	360	180	225	5b	100	75	1120	190	360	490	440	22	100	594	77	203
		18.5		65	50	100	360	180	225	5b	100	75	1120	190	360	490	440	22	100	594	77	217
		22		65	50	100	360	180	225	5b	100	75	1120	190	360	490	440	22	100	594	77	230
		30		65	50	100	360	180	225	5b	100	75	1120	190	360	490	440	22	100	784	86	332
50-315		4.0		65	50	125	470	225	280	5b	100	75	1120	190	360	490	440	22	140	365	59	185
		5.5		65	50	125	470	225	280	5b	100	75	1120	190	360	490	440	22	140	450	67	201
	7.5		65	50	125	470	225	280	5b	100	75	1120	190	360	490	440	22	140	450	67	205	
	11		65	50	125	470	225	280	6b	100	75	1250	205	410	540	490	22	140	594	70	243	
		30		65	50	125	470	225	280	7b	100	75	1400	230	480	610	550	25	140	784	86	372
		37		65	50	125	470	225	280	7b	100	75	1400	230	480	610	550	25	140	784	86	372
		45		65	50	125	470	225	280	7b	100	75	1400	230	480	610	550	25	140	784	86	296
		55		65	50	125	470	225	280	8d	152	110	1600	270	508	660	600	25	140	882	86	681
		75		65	50	125	470	225	280	8d	152	110	1600	270	508	660	600	25	140	1070	87	741
	65-125	0.75		80	65	100	360	160	180	3b	75	75	900	150	290	390	350	20	100	269	55	86
1.1			80	65	100	360	160	180	3b	75	75	900	150	290	390	350	20	100	294	57	89	
1.5			80	65	100	360	160	180	3b	75	75	900	150	290	390	350	20	100	294	57	90	

TD pumpset dimensions

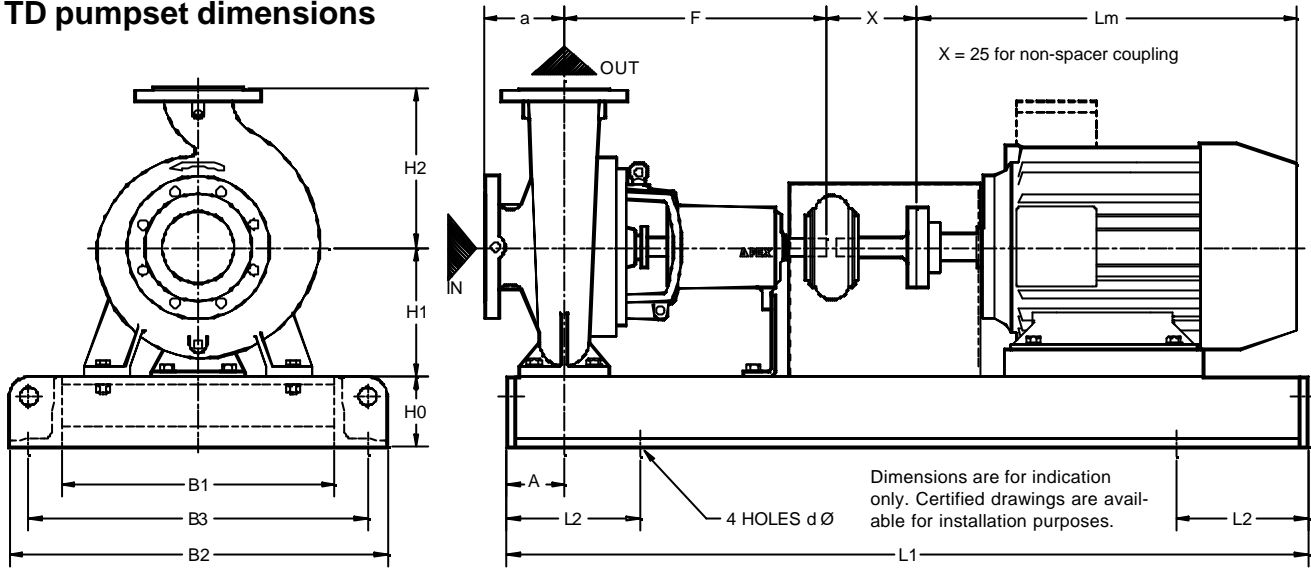

Pump & motor			Pump dimensions						Bedplate dimensions								dB	kg			
TD Pump	1450 rpm	2900 rpm	In	Out	a	F	H1	H2	Bed ref	H0	A	L1	L2	B1	B2	B3			d	X	Lm
65-125	5.5		80	65	100	360	160	180	4b	75	75	1000	170	350	450	400	22	100	450	74	126
	7.5		80	65	100	360	160	180	4b	75	75	1000	170	350	450	400	22	100	450	74	126
	11		80	65	100	360	160	180	5b	100	75	1120	190	360	490	440	22	100	594	77	179
65-160	1.1		80	65	100	360	160	200	3b	75	75	900	150	290	390	350	20	100	294	57	95
	1.5		80	65	100	360	160	200	3b	75	75	900	150	290	390	350	20	100	294	57	96
	2.2		80	65	100	360	160	200	3b	75	75	900	150	290	390	350	20	100	365	58	106
	7.5		80	65	100	360	160	200	4b	75	75	1000	170	350	450	400	22	100	450	74	132
	11		80	65	100	360	160	200	5b	100	75	1120	190	360	490	440	22	100	594	77	185
	15		80	65	100	360	160	200	5b	100	75	1120	190	360	490	440	22	100	594	77	185
65-200	1.5		80	65	100	360	180	225	4b	75	75	1000	170	350	450	400	22	100	294	57	111
	2.2		80	65	100	360	180	225	4b	75	75	1000	170	350	450	400	22	100	365	58	121
	3.0		80	65	100	360	180	225	4b	75	75	1000	170	350	450	400	22	100	365	58	121
	4.0		80	65	100	360	180	225	4b	75	75	1000	170	350	450	400	22	100	365	59	125
	15		80	65	100	360	180	225	5b	100	75	1120	190	360	490	440	22	100	594	77	194
	18.5		80	65	100	360	180	225	5b	100	75	1120	190	360	490	440	22	100	594	77	208
	22		80	65	100	360	180	225	5b	100	75	1120	190	360	490	440	22	100	594	77	221
	30		80	65	100	360	180	225	6b	100	75	1250	205	410	540	490	22	100	784	86	321
65-250	3.0		80	65	100	470	200	250	6c	100	90	1250	205	410	540	490	22	140	365	58	189
	4.0		80	65	100	470	200	250	6c	100	90	1250	205	410	540	490	22	140	365	59	193
	5.5		80	65	100	470	200	250	6c	100	90	1250	205	410	540	490	22	140	450	67	209
	7.5		80	65	100	470	200	250	6c	100	90	1250	205	410	540	490	22	140	450	67	213
	30		80	65	100	470	200	250	6c	100	90	1250	205	410	540	490	22	140	784	86	364
	37		80	65	100	470	200	250	6c	100	90	1250	205	410	540	490	22	140	784	86	364
	45		80	65	100	470	200	250	7c	100	90	1400	230	480	610	550	25	140	784	86	395
	55		80	65	100	470	200	250	8c	152	90	1600	270	508	660	600	25	140	882	86	588
65-315	7.5		80	65	125	470	225	280	6c	100	90	1250	205	410	540	490	22	140	450	67	231
	11		80	65	125	470	225	280	6c	100	90	1250	205	410	540	490	22	140	594	70	262
	55		80	65	125	470	225	280	8c	152	90	1600	270	508	660	600	25	140	882	86	606
	75		80	65	125	470	225	280	9c	152	90	1800	300	578	730	670	25	140	1070	87	681
	90		80	65	125	470	225	280	9c	152	90	1800	300	578	730	670	25	140	923	90	791
	80-160	1.5		100	80	125	360	180	225	4b	75	75	1000	170	350	450	400	22	100	294	57
2.2		100	80	125	360	180	225	4b	75	75	1000	170	350	450	400	22	100	365	58	121	
3.0		100	80	125	360	180	225	4b	75	75	1000	170	350	450	400	22	100	365	58	121	
15		100	80	125	360	180	225	5b	100	75	1120	190	360	490	440	22	100	594	77	194	
18.5		100	80	125	360	180	225	5b	100	75	1120	190	360	490	440	22	100	594	77	208	
22		100	80	125	360	180	225	5b	100	75	1120	190	360	490	440	22	100	594	77	221	
30		100	80	125	360	180	225	6b	100	75	1250	205	410	540	490	22	100	784	86	321	
80-200	3.0		100	80	125	470	180	250	5b	100	75	1120	190	360	490	440	22	140	365	58	156
	4.0		100	80	125	470	180	250	5b	100	75	1120	190	360	490	440	22	140	365	59	160
	5.5		100	80	125	470	180	250	5b	100	75	1120	190	360	490	440	22	140	450	67	176
	30		100	80	125	470	180	250	7b	100	75	1400	230	480	610	550	25	140	784	86	347
	37		100	80	125	470	180	250	7b	100	75	1400	230	480	610	550	25	140	784	86	347
45		100	80	125	470	180	250	7b	100	75	1400	230	480	610	550	25	140	784	86	367	
80-250	4.0		100	80	125	470	200	280	6c	100	90	1250	205	410	540	490	22	140	365	59	198
	5.5		100	80	125	470	200	280	6c	100	90	1250	205	410	540	490	22	140	450	67	214
	7.5		100	80	125	470	200	280	6c	100	90	1250	205	410	540	490	22	140	450	67	218
	11		100	80	125	470	200	280	6c	100	90	1250	205	410	540	490	22	140	594	70	249

TD pumpset dimensions

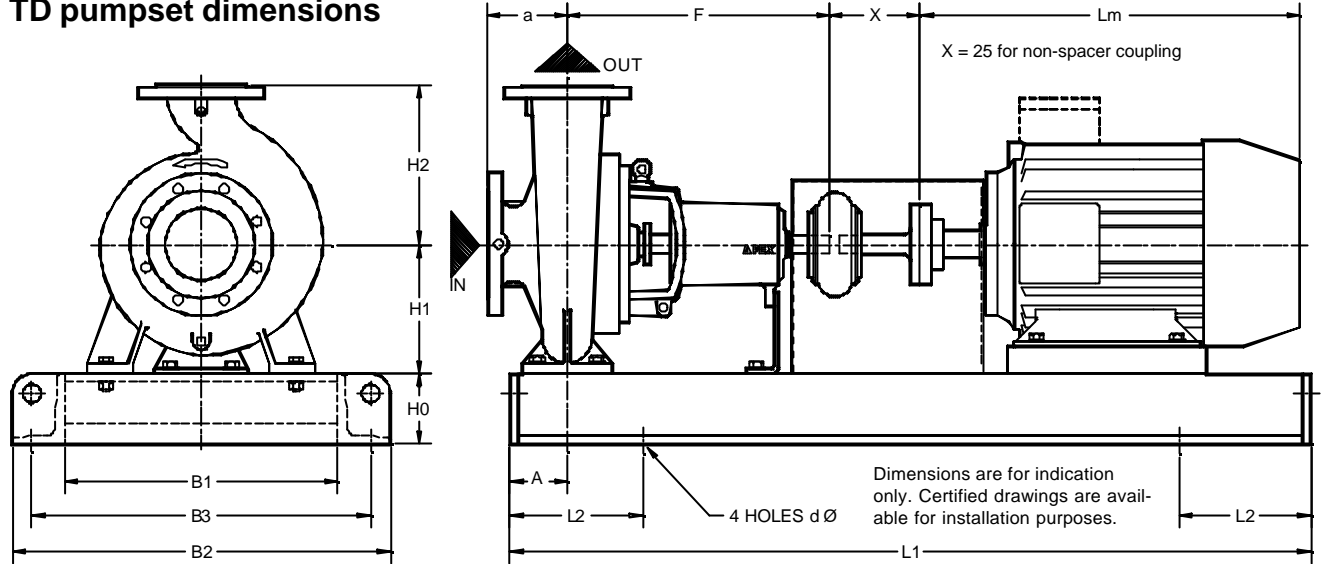

Pump & motor		Pump dimensions							Bedplate dimensions										dB	kg		
TD Pump	1450 rpm	2900 rpm	In	Out	a	F	H1	H2	Bed ref	H0	A	L1	L2	B1	B2	B3	d	X			Lm	
80-250	37		100	80	125	470	200	280	7c	100	90	1400	230	480	610	550	25	140	784	86	380	
	45		100	80	125	470	200	280	7c	100	90	1400	230	480	610	550	25	140	784	86	400	
	55		100	80	125	470	200	280	8c	152	90	1600	270	508	660	600	25	140	882	86	593	
	75		100	80	125	470	200	280	9c	152	90	1800	300	578	730	670	25	140	1070	87	653	
80-315	7.5		100	80	125	470	250	315	6c	100	90	1250	205	410	540	490	22	140	450	67	231	
	11		100	80	125	470	250	315	6c	100	90	1250	205	410	540	490	22	140	594	70	262	
	15		100	80	125	470	250	315	6c	100	90	1250	205	410	540	490	22	140	594	70	276	
	18.5		100	80	125	470	250	315	6c	100	90	1250	205	410	540	490	22	140	594	70	289	
		75		100	80	125	470	250	315	9c	152	90	1800	300	578	730	670	25	140	1070	87	681
		90		100	80	125	470	250	315	9c	152	90	1800	300	578	730	670	25	140	1200	90	741
	110		100	80	125	470	250	315	9c	152	90	1800	300	578	730	670	25	140	1200	92	841	
80-400	15		100	80	125	530	280	355	7c	100	90	1400	230	480	610	550	25	140	594	70	345	
	18.5		100	80	125	530	280	355	7c	100	90	1400	230	480	610	550	25	140	594	70	358	
	22		100	80	125	530	280	355	7c	100	90	1400	230	480	610	550	25	140	651	74	396	
	30		100	80	125	530	280	355	7c	100	90	1400	230	480	610	550	25	140	705	78	407	
100-160	3.0		125	100	125	470	200	250	5c	100	90	1120	190	360	490	440	22	140	365	58	166	
	4.0		125	100	125	470	200	250	5c	100	90	1120	190	360	490	440	22	140	365	59	170	
		18.5	125	100	125	470	200	250	6c	100	90	1250	205	410	540	490	22	140	594	77	253	
		22	125	100	125	470	200	250	6c	100	90	1250	205	410	540	490	22	140	594	77	266	
		30	125	100	125	470	200	250	7c	100	90	1400	230	480	610	550	25	140	784	86	370	
100-200	4.0		125	100	125	470	200	280	5c	100	90	1120	190	360	490	440	22	140	365	59	177	
	5.5		125	100	125	470	200	280	5c	100	90	1120	190	360	490	440	22	140	450	67	193	
	7.5		125	100	125	470	200	280	5c	100	90	1120	190	360	490	440	22	140	450	67	197	
		37	125	100	125	470	200	280	7c	100	90	1400	230	480	610	550	25	140	784	86	377	
		45	125	100	125	470	200	280	7c	100	90	1400	230	480	610	550	25	140	784	86	397	
		55	125	100	125	470	200	280	8c	152	90	1600	270	508	660	600	25	140	882	86	590	
	75	125	100	125	470	200	280	8c	152	90	1600	270	508	660	600	25	140	1070	87	672		
	90	125	100	125	470	200	280	9c	152	90	1800	300	578	730	670	25	140	1200	90	732		
	110	125	100	125	470	200	280	9c	152	90	1800	300	578	730	670	25	140	1200	92	832		
100-250	7.5		125	100	140	470	225	280	6c	100	90	1250	205	410	540	490	22	140	450	67	237	
	11		125	100	140	470	225	280	6c	100	90	1250	205	410	540	490	22	140	594	70	268	
	15		125	100	140	470	225	280	6c	100	90	1250	205	410	540	490	22	140	594	70	282	
		55	125	100	140	470	225	280	8c	152	90	1600	270	508	660	600	25	140	882	86	612	
		75	125	100	140	470	225	280	8c	152	90	1600	270	508	660	600	25	140	1070	87	672	
		90	125	100	140	470	225	280	9c	152	90	1800	300	578	730	670	25	140	1200	90	732	
		110	125	100	140	470	225	280	9c	152	90	1800	300	578	730	670	25	140	1200	92	832	
		160	125	100	140	470	225	280	11e	203	140	2000	330	772	950	870	25	140	1036	95	1057	
100-315	11		125	100	140	470	250	315	6c	100	90	1250	205	410	540	490	22	140	594	70	278	
	15		125	100	140	470	250	315	6c	100	90	1250	205	410	540	490	22	140	594	70	292	
	18.5		125	100	140	470	250	315	6c	100	90	1250	205	410	540	490	22	140	594	70	305	
	22		125	100	140	470	250	315	7c	100	90	1400	230	480	610	550	25	140	651	74	354	
	90		125	100	140	470	250	315	9c	152	90	1800	300	578	730	670	25	140	923	90	757	
	110		125	100	140	470	250	315	9c	152	90	1800	300	578	730	670	25	140	923	92	857	
	132		125	100	140	470	250	315	9c	152	90	1800	300	578	730	670	25	140	923	95	857	
	160		125	100	140	470	250	315	11e	203	140	2000	330	772	950	870	25	140	1036	95	1057	
100-400	22		125	100	140	530	280	355	8d	152	110	1600	270	508	660	600	25	140	594	74	401	
	30		125	100	140	530	280	355	8d	152	110	1600	270	508	660	600	25	140	705	78	412	
	37		125	100	140	530	280	355	8d	152	110	1600	270	508	660	600	25	140	705	78	475	
	45		125	100	140	530	280	355	8d	152	110	1600	270	508	660	600	25	140	784	86	495	
125-200	7.5		150	125	140	470	250	315	6c	100	90	1250	205	410	540	490	22	140	450	67	225	
	11		150	125	140	470	250	315	6c	100	90	1250	205	410	540	490	22	140	594	70	256	

TD pumpset dimensions

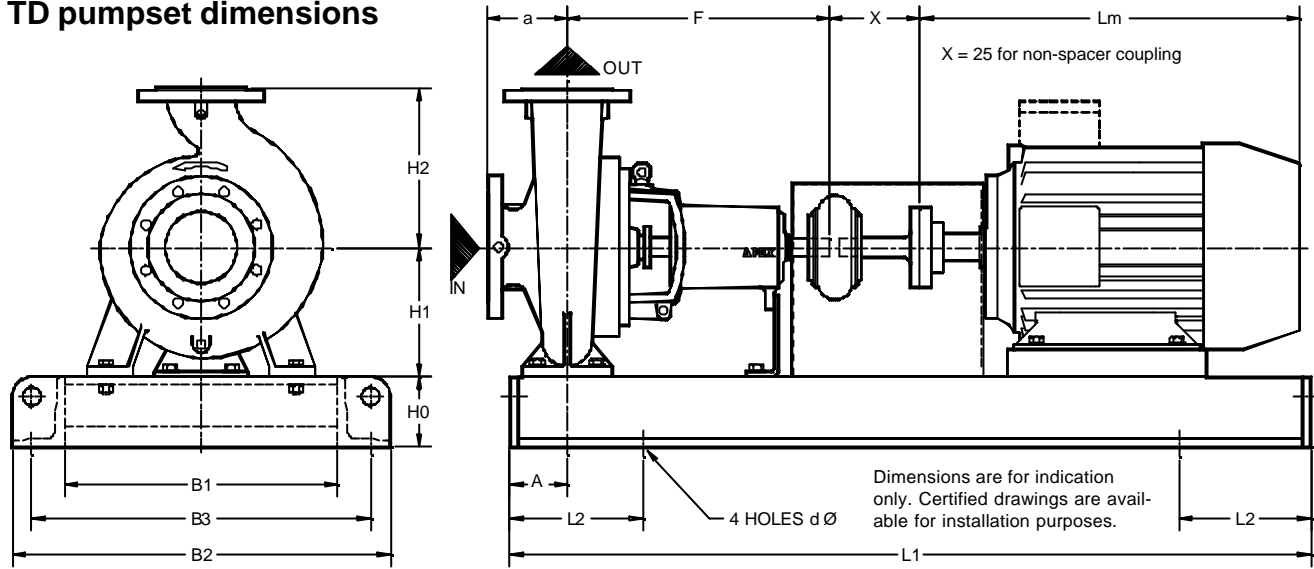

Pump & motor TD Pump 1450 2900 rpm rpm	Pump dimensions							Bedplate dimensions										dB	kg	
	In	Out	a	F	H1	H2	Bed ref	H0	A	L1	L2	B1	B2	B3	d	X	Lm			
125-200	55	150	125	140	470	250	315	8c	152	90	1600	270	508	660	600	25	140	882	86	600
	75	150	125	140	470	250	315	9c	152	90	1800	300	578	730	670	25	140	1070	87	660
	90	150	125	140	470	250	315	9c	152	90	1800	300	578	730	670	25	140	923	90	770
125-250	11	150	125	140	470	250	355	6c	100	90	1250	205	410	540	490	22	140	594	70	273
	15	150	125	140	470	250	355	6c	100	90	1250	205	410	540	490	22	140	594	70	287
	18.5	150	125	140	470	250	355	6c	100	90	1250	205	410	540	490	22	140	594	70	300
125-315	15	150	125	140	530	280	355	8d	152	110	1600	270	508	660	600	25	140	594	70	383
	18.5	150	125	140	530	280	355	8d	152	110	1600	270	508	660	600	25	140	594	70	396
	22	150	125	140	530	280	355	8d	152	110	1600	270	508	660	600	25	140	651	74	434
	30	150	125	140	530	280	355	8d	152	110	1600	270	508	660	600	25	140	705	78	445
125-400	30	150	125	140	530	315	400	8d	152	110	1600	270	508	660	600	25	140	705	78	479
	37	150	125	140	530	315	400	8d	152	110	1600	270	508	660	600	25	140	814	78	542
	45	150	125	140	530	315	400	8d	152	110	1600	270	508	660	600	25	140	814	78	562
	55	150	125	140	530	315	400	8d	152	110	1600	270	508	660	600	25	140	882	79	723
150-200	11	200	150	160	500	280	400	7d	100	110	1400	230	480	610	550	25	140	594	70	295
	15	200	150	160	500	280	400	7d	100	110	1400	230	480	610	550	25	140	594	70	309
	18.5	200	150	160	500	280	400	7d	100	110	1400	230	480	610	550	25	140	594	70	322
150-250	18.5	200	150	160	530	250	355	7d	100	110	1400	230	480	610	550	25	140	594	70	358
	22	200	150	160	530	250	355	7d	100	110	1400	230	480	610	550	25	140	651	74	396
	30	200	150	160	530	250	355	8d	152	110	1600	270	508	660	600	25	140	784	78	440
150-315	30	200	150	160	530	280	400	9d	152	110	1800	300	578	730	670	25	140	784	78	483
	37	200	150	160	530	280	400	9d	152	110	1800	300	578	730	670	25	140	814	78	546
	45	200	150	160	530	280	400	9d	152	110	1800	300	578	730	670	25	140	814	78	566
	55	200	150	160	530	280	400	9d	152	110	1800	300	578	730	670	25	140	882	79	727
150-400	37	200	150	160	530	315	450	9d	152	110	1800	300	578	730	670	25	140	814	78	571
	45	200	150	160	530	315	450	9d	152	110	1800	300	578	730	670	25	140	814	78	591
	55	200	150	160	530	315	450	9d	152	110	1800	300	578	730	670	25	140	882	79	752
	75	200	150	160	530	315	450	9d	152	110	1800	300	578	730	670	25	140	1070	87	792
200-250	37	250	200	180	553	315	450	9d	152	110	1800	300	578	730	670	25	180	814	78	601
	45	250	200	180	553	315	450	9d	152	110	1800	300	578	730	670	25	180	814	78	621
	55	250	200	180	553	315	450	9d	152	110	1800	300	578	730	670	25	180	923	81	782
200-315	45	250	200	180	670	315	480	10e	152	140	1900	315	698	850	780	28	180	814	78	736
	55	250	200	180	670	315	480	10e	152	140	1900	315	698	850	780	28	180	923	81	897
	75	250	200	180	670	315	480	10e	152	140	1900	315	698	850	780	28	180	1036	82	1122
200-400	75	250	200	180	670	335	480	10e	152	140	1900	315	698	850	780	28	180	1036	82	1166
	90	250	200	180	670	335	480	10e	152	140	1900	315	698	850	780	28	180	1036	82	1276
	110	250	200	180	670	335	480	11e	203	140	2000	330	772	950	870	28	180	1156	84	1342
	132	250	200	180	670	335	480	11e	203	140	2000	330	772	950	870	28	180	1156	84	1522
250-315	45	300	250	220	691	355	520	10e	152	140	1900	315	698	850	780	28	180	814	78	796
	55	300	250	220	691	355	520	10e	152	140	1900	315	698	850	780	28	180	923	81	957
	75	300	250	220	691	355	520	10e	152	140	1900	315	698	850	780	28	180	1036	82	1182
250-400	110	300	250	220	682	400	560	11e	203	140	2000	330	772	950	870	28	180	1156	84	1437
	132	300	250	220	682	400	560	11e	203	140	2000	330	772	950	870	28	180	1156	84	1617
	160	300	250	220	682	400	560	11e	203	140	2000	330	772	950	870	28	180	1156	84	1622