

Avfukter Recusorb

RLZ-81, -101, -102 RENTAL

DST 

Tørrluftmengde
4500 - 12000 m³/h

- Vaskbar rotor
- Rotoren avgir ikke støy
- Utviklet for mobil bruk
- Innebygd varmegjenvinning
- Lav tørrluft-temperatur
- Lang levetid

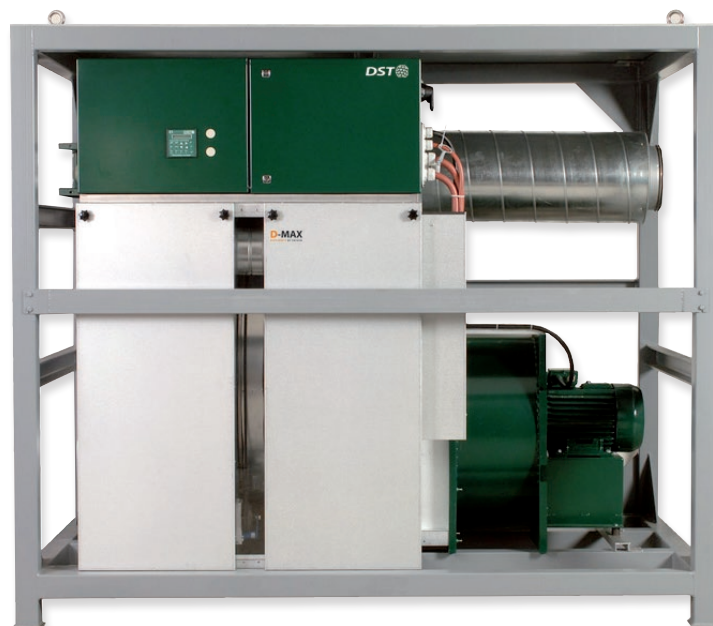

*Utsnitt av en avfukterrotor
fra Seibu Giken. Takket være
de mange kanalene tas
fuktigheten effektivt opp.*

World leaders in dehumidification.

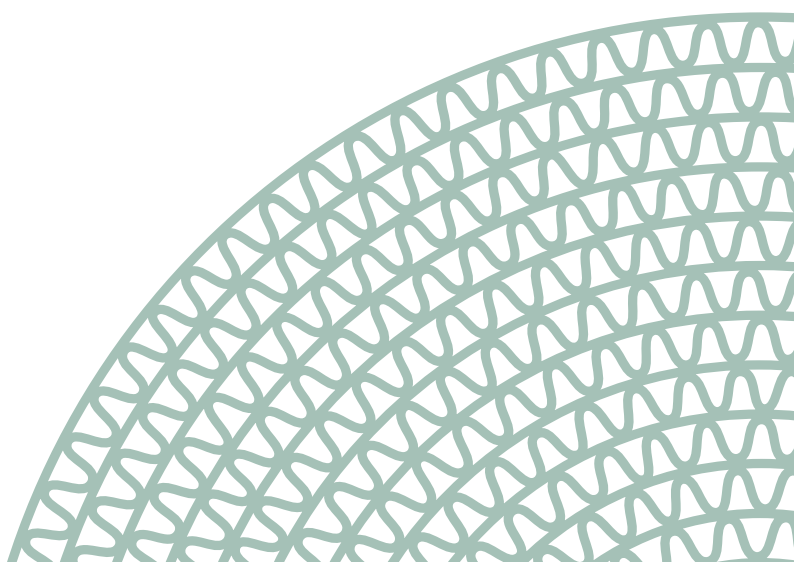

TEKNISKE DATA

Avfuker type	RLZ-81	RLZ-101	RLZ-102
Tørrluftmengde ² (m ³ /h)	4500	9000	12000
ved eksternt statisk trykk (Pa)	300	300	300
Våtluftmengde ² (m ³ /h)	750	1800	2500
ved eksternt statisk trykk (Pa)	200	200	200
Varmebatteriets effekt ³ (kW)	24	40	63
Anslutningseffekt (kW)	27,6	47	74
Sikring 3x400V 50Hz (A)	80 / 50	125 / 80	- / 125
Vekt (kg)	800	910	1060

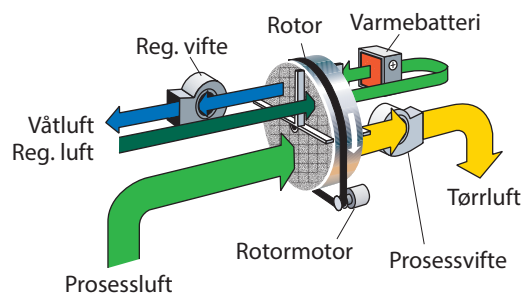

1. Luftmengde ved densitet 1,20 kg/m³.
2. I standardversjonen er enheten utstyrt med varmebatteri, mens dampbatteri er valgfritt.

KAPASITETSTABELL

Kapazität (kg/h)		10°C			15°C			20°C		
		30%RF	50%RF	70%RF	30%RF	50%RF	70%RF	30%RF	50%RF	70%RF
RLZ-81 RENTAL	*	9,5	14,0	17,0	12,0	16,5	19,0	14,5	18,5	19,9
	**	8,5	13,0	16,0	10,5	15,0	18,5	12,5	17,0	19,0
RLZ-101 RENTAL	*	16,5	23,5	28,0	21,0	27,5	31,0	24,5	30,0	32,0
	**	14,0	21,5	27,0	17,5	25,0	30,5	20,5	28,0	31,0
RLZ-102 RENTAL	*	27,0	40,5	48,0	35,0	47,0	53,0	42,0	51,0	54,0
	**	24,5	37,0	46,0	31,0	43,5	52,0	36,5	48,0	52,5

* Reaktive luft i samme tilstand som prosessluften.

** Reaktive luft inn 25°C 12 g/kg.

DIMENSJONER

Kan endres uten varsel. Installasjon tegning for nedlasting fra www.dst-sg.com

	RLZ-81	RLZ-101	RLZ-102		RLZ-81	RLZ-101	RLZ-102
A	2066	2550	2550	D	Ø400	Ø500	Ø630
B	1216	1516	1516	F	Ø200	Ø315	Ø400
C	1916	2156	2156	G	Ø160	Ø250	Ø315

Dimensjoner for □E

RLZ-81: 630 x 236

RLZ-101: 786 x 306

RLZ-102: 880 x 338

(mm)

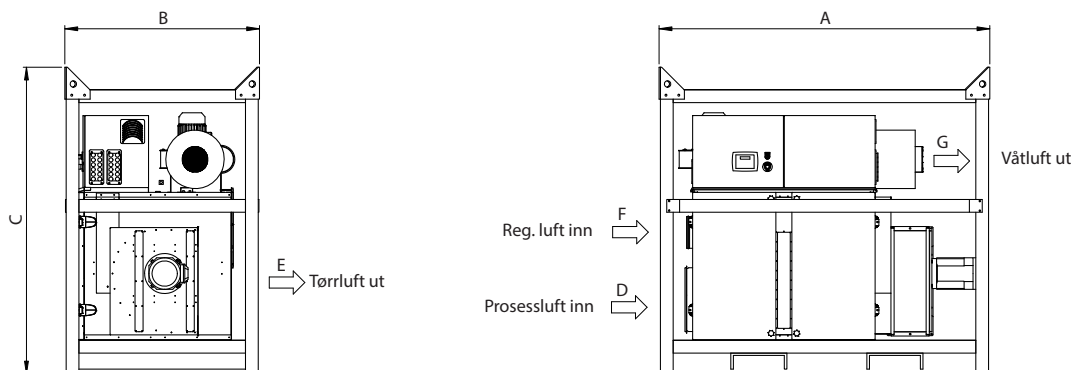

Updated 18.12



Sweden | +46 8 445 77 20
info@dst-sg.com | www.dst-sg.com