



Alfsen og Gunderson

EXPERTS IN PUMPS, DEHUMIDIFICATION AND
WATER TREATMENT FOR OFFSHORE



Alfsen og Gunderson | Telephone +47 22 70 77 00 | www.ag.no



Alfsen og Gunderson is a Norwegian supplier of systems and products, based in Oslo and Bergen. We specialise in pumps, chemical injection, dehumidification and water treatment. The company has extensive experience in the offshore sector, and we have been a supplier since the 1970s.

At AG, we have our own in-house resources in the fields of automation, design, documentation and servicing. We design and supply tailor-made equipment worldwide, based on our proprietary technology and in cooperation with respected manufacturers.

URGENT OR PREVENTIVE SERVICE

AG has its own service team with the necessary specialist expertise in air, water and pump technology. We follow up our deliveries, and assist with commissioning, troubleshooting or ongoing service agreements, both offshore and onshore. We also provide bespoke courses and training on equipment when needed.

Please contact us – the service we provide ensures stable operation and extends the service life of the equipment!



Alfsen og Gunderson

Brynsveien 5
NO-0667 Oslo
Norway

+47 22 70 77 00
post@ag.no



NEW PUMP SOLUTION FROM AG

We have developed a new concept that combines a vacuum ejector and tank with a pneumatically driven pump.

This arrangement is suitable for demanding applications where the pump alone has insufficient power to initiate lifting (dry suction).

The objective of the application is to utilise the vacuum ejector's lifting capacity to prime the pump's suction line, so that the pump can take over operation once the line is primed. The equipment shown has recently been delivered to the Johan Sverdrup field, where it will be used as a diesel-sampling and drain pump unit.

- Increases lifting capacity at start-up of pump (dry suction) from 5 m to 8 m
- Compact
- Mobile
- Dependent only on air



API 610 pumps for Johan Sverdrup's landing terminal

AG has recently delivered two complete API 610 VS4 pump units to Aker Solutions, to be installed at the new landing terminal in Mongstad for the Johan Sverdrup field. The pumps have been supplied in 316 material and are to be used as drainage pumps for oily water. They have been manufactured in accordance with current NORSOK, TR and API requirements.



AG is also assisting in connection with commissioning on site.

New pumps for the Johan Castberg platform

Three offshore pump skids with Dickow multistage and single-stage pumps have been delivered to NOV.

The pumps, which have ABB motors and noise hoods, will be installed on the Johan Castberg platform, where they will be used to purify produced water.

The pumps have been supplied in accordance with ISO 5199, with various additional requirements from the customer.

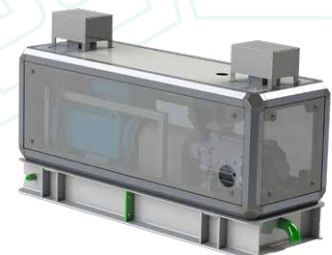

Jotun/Balder FPSO

AG has just completed delivery of two API 610 Heating Medium Circulation pump skids and one Make Up Water Skid to Aker Solutions.





DOSING PUMPS – OBL

- Chemical injection
- API 675
- 0–4,000 l/h, max. 350 bar
- Hydraulically actuated double diaphragms
- Integrated diaphragm monitoring
- Integrated safety valve
- Manual and electric/pneumatic stroke adjustment
- NORSOK/TR specifications

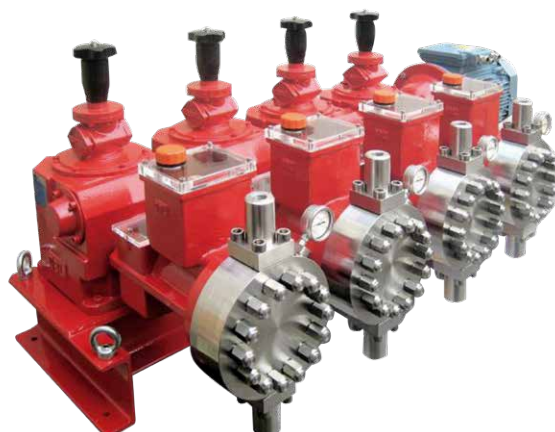

OBL multi-head dosing pump supplied to Vincent FPSO



YAMADA air-actuated diaphragm pump with clack valves for media containing particulates

AIR-DRIVEN DIAPHRAGM PUMPS – YAMADA

- ATEX-approved
- Materials Stainless Steel, Duplex, PVDF, Aluminium
- 0–840 l/min
- Can be painted in accordance with NORSOK-M501
- Custom frames

HIGH-PRESSURE PUMPS – RAM AND CAT

- 0–100 m³/h and 700 bar pressure
- Methanol and chemical injection
- TEG circulation packages
- NORSOK/TR specifications



RAM injection pump, supplied to Troll A and Etrick FPSO

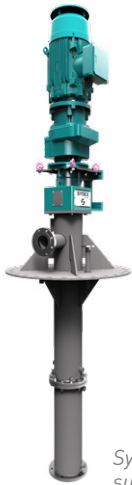

*Sydex vertical eccentric screw pump
supplied to Johan Sverdrup FPSO*

ECCENTRIC SCREW PUMPS – TORQUEFLOW SYDEX

- API 676
- Horizontal or vertical design
- 20 L/h – 399 m³/h, max. 48 bar
- Self-priming
- Minimal pulsation and vibration
- NORSOK/TR specifications

CENTRIFUGAL PUMPS – DICKOW AND SUNDYNE MARELLI

- API 610 according to the latest edition
- Horizontal, vertical, single- and multi-stage design
- NORSOK/TR specifications
- Crude oil, condensate, produced water, flare transfer
- heating medium, TEG transfer



*Dickow API 610 VS4 with noise hoods,
supplied to Johan Sverdrup*



3P Prinz vertical API 676 screw pump

SCREW PUMPS – 3P PRINZ

- Gear and screw pumps according to API 676, latest edition
- Pulsation-free liquid transport
- Up to : 8,5 m suction lift
- Viscosity up to 50,000 cSt
- 0–3,500 m³/h, max. 60 bar pressure
- 150 bar design pressure
- Low noise and minimal vibration
- Internal/external oil-lubricated gears
- Gas/liquid admixture up to 50%
- For crude oil, chemicals, produced water



AG supplies dehumidifiers that effectively prevent condensation and corrosion. This greatly reduces the need for maintenance. Safe and permanent corrosion protection in voids, platform legs, double bottoms, tanks, storage

rooms, lifeboats etc.

Dehumidifiers are also ideal for protecting rigs and ships in lay-up. AG supplies ATEX dehumidifiers for zones 1 and 2, in addition to a wide range of standard dehumidifiers for safe zones.

STANDARD DST DEHUMIDIFIERS

Where Ex-safe humidifiers are not required, AG supplies DST humidifiers in a range of sizes.

- Robust and reliable dehumidifiers
- Air volumes from 100 m³/h to 50,000 m³/h
- Work regardless of temperature, even below 0 °C



ATEX DEHUMIDIFIERS

- Air flows from 500 m³/h to 12,000 m³/h
- ATEX for zones 1 and 2
- Robust and reliable

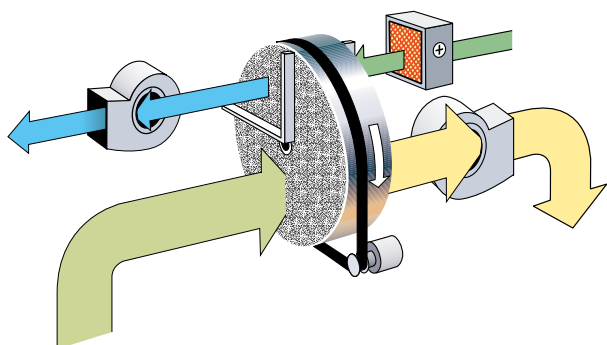

References:

- Equinor Energy
- ConocoPhillips: EKOB and ELDA platform
- ExxonMobil: Adriatic LNG
- Linjebygg Offshore
- Bilfinger
- Visund
- Troll C
- Njord B
- Maersk
- Odfjell



ATEX DEHUMIDIFIERS AS PERMANENT CORROSION PROTECTION

The photo on the right shows the ATEX AG-EX-61E dehumidifier supplied to ConocoPhillips's requirements, as installed on Ekofisk B in 2016 and Eldfisk A in 2019. The system maintains a low RH in the tanks and also monitors any leaks, e.g. from open inspection hatches.

The old process tanks are part of the strength of the platform, and the dehumidifier keeps them dry and corrosion-free.

The dehumidifier has a robust design to ensure long life, and is manufactured completely in 316L. It is based on a silicate rotor. AG has been supplying sorption dehumidifiers since 1960, and has been designing and supplying EX sorption dehumidifiers with electric regeneration heating coils since 2007.



MOBILE ATEX DRY AIR SOLUTIONS

AG also supplies mobile ATEX container dehumidifiers, that can be used to keep surfaces dry during surface treatment jobs. As a result, such work can be planned and carried out regardless of the weather. This makes the work more efficient, and provides a longer lifetime of the surface treatment.



Climate container with a dry-air flow of 4,500 m³/h, delivered to Bilfinger



Climate container with a dry-air flow of 12,000 m³/h, delivered to Linjebygg Offshore AS



PRESERVATION OF SHIPS AND RIGS IN LAY-UP

Dry air is the safest, most environmentally friendly and most affordable method

Dry air can protect almost any room and all equipment. Steel, electronics, electrical equipment, fixtures, textiles and other items can be safely protected against moisture damage and corrosion. The system works regardless of temperature, and it is very easy to monitor the protection.

Dehumidification is a proven, safe and environmentally friendly method that ensures that all equipment is in good condition and without moisture damage when the ship or rig is needed once again. AG's extensive experience with assignments of this kind ensures quality solutions and good results.

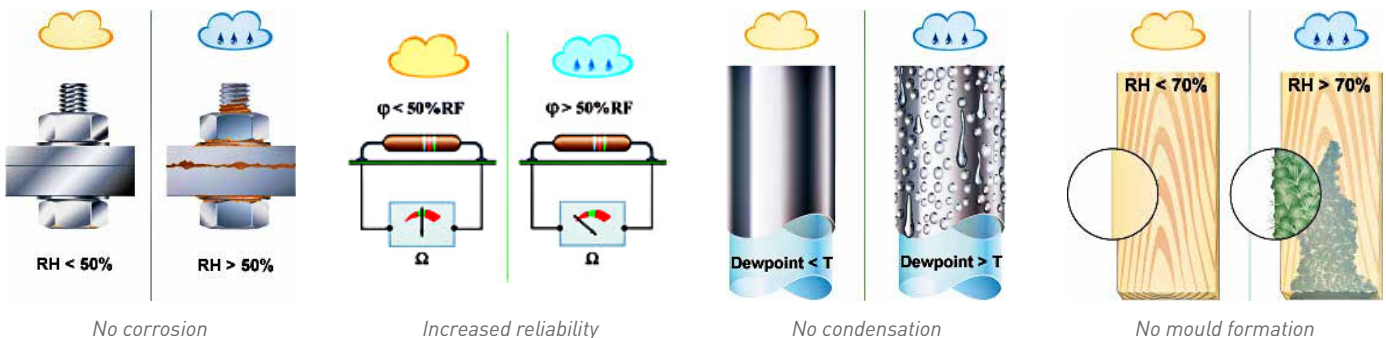
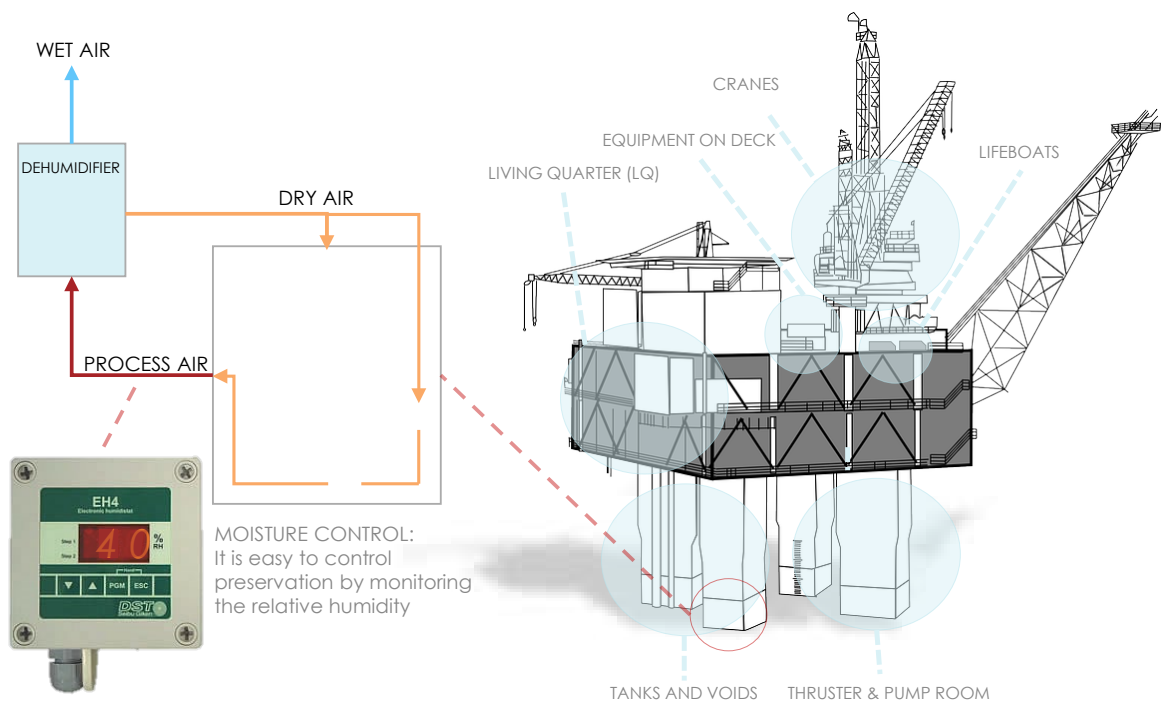

References:

AG has dry-air preserved the following rigs and drilling vessels:

Belford Dolphin
 AKOFS Seafarer
 Transocean Barents

Transocean Spitsbergen
 Haven
 Odfjell Metro II

Scarabeo 5
 Floatel Endurance
 Arendal Spirit



EX-SAFE WATER TREATMENT OFFSHORE

The water-supply systems on the Statfjord B and C, Gullfaks C, Snorre A, Gjøa, Gudrun and Oseberg platforms – as well as a number of others – all feature water-treatment plants from Alfsen og Gunderson. The filters, UV systems and chlorine-dosing systems have been designed in accordance with the Norwegian Institute of Public Health's requirements for offshore installations.

- Designed and manufactured in Norway
- UV systems certified by NIPH and in ATEX-approved designs
- Compact solutions with extremely low power requirements
- Designed in accordance with TR 1990 and Water Report 128 from NIPH

If necessary, the skids can be equipped with panels for thermal insulation or be installed in a container.

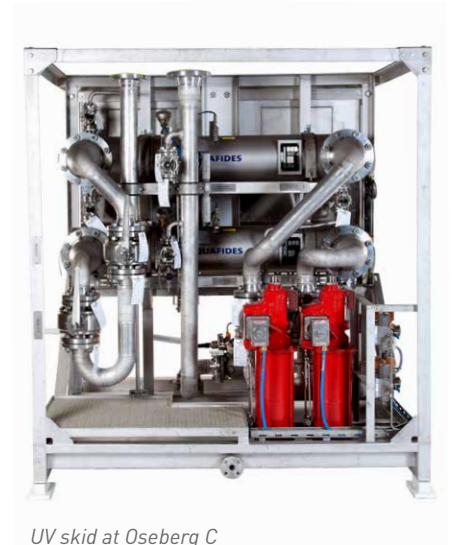

UV skid at Oseberg C

UV SYSTEMS – TYPE-APPROVED BY THE NORWEGIAN INSTITUTE OF PUBLIC HEALTH

Our UV systems are type-approved according to the latest standard with a biosimetrically tested UV dose of 40 mJ/cm². The systems use UV lamps with a very high efficiency and low power consumption.

- High-efficiency, low-pressure UV lamps with a certified operating time of 14,000 hours
- Delivered with full local control, or alternatively with starting equipment only and based on control from a central control room



Lamp connection in Ex-safe and service-friendly construction





BASKET STRAINERS, BAG FILTERS AND CARTRIDGE FILTERS

We supply filters in simplex, duplex and multi-bag versions for water and process liquids

- Standard filter, or tailor-made solutions for skids with valves, pipework and instrumentation
- Wide range of materials, dimensions and degrees of filtration

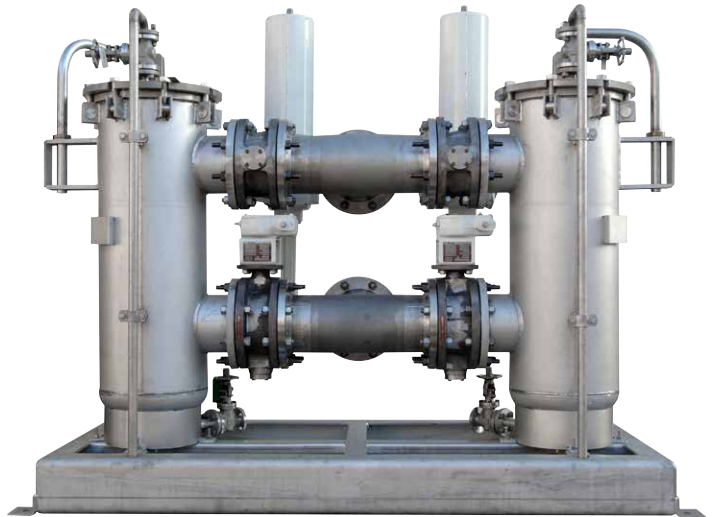

Seawater filtration on the Tambar platform

AUTOMATIC BACKWASH FILTER FOR DRINKING WATER AND SEAWATER

AG's JET filter has the smartest backwash function on the market and no moving parts in the filter housing. It is fitted in-line in a horizontal or vertical position.

- Filtration down to 50 microns and pipe dimensions up to DN 3000
- Efficient and automatic flushing of filter tubes
- No moving parts means minimal need for inspection and replacement of parts
- Supplied in painted carbon steel, seawater-resistant and M650-approved steel grades or synthetic material

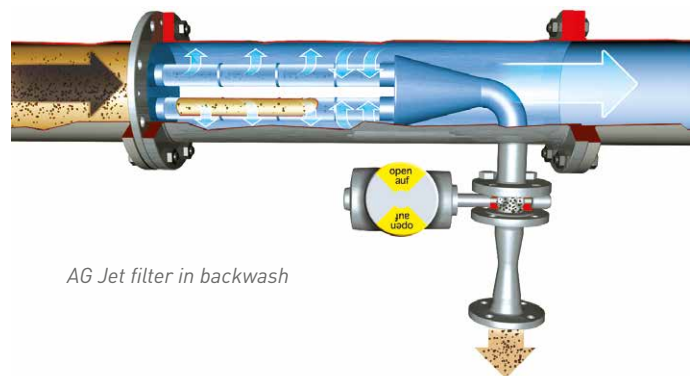

AG Jet filter in backwash



CHEMINEER AGITATORS

Our agitators are specially designed according to the customer's process descriptions and needs. With our many years of experience with agitators for the process industry and the use of advanced design tools, we will always find a solution for the most demanding applications.

- Used for mud applications, mixing chemicals for injection and mixing viscous, abrasive and corrosive media
- Wide range of impeller types and material qualities
- Extremely robust gears that are specially adapted for use in agitators



Chemineer agitators

KENICS IN-LINE STATIC MIXERS

We have the original product and can boast more than 50 years' experience in mixing technology. Static mixers are used for efficiently mixing a range of chemicals and gases, and also when there is a need for accurate sampling results.

- Static mixers have no moving parts and thus a minimal need for inspection and maintenance
- Effective homogenisation of both liquid and gas mixtures
- Accurate determination of water content in crude oil and hydrocarbon streams in "custody transfer" applications

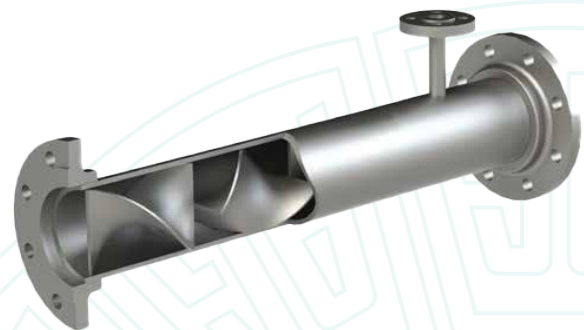

KENICS static mixer with sampling point

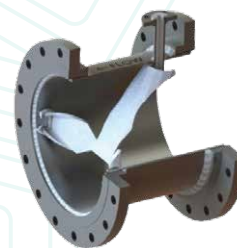

UltraTab – very compact static mixer



OUR CONTACTS FOR THE OFFSHORE MARKET



Gard Christensen

Product Manager, Pumps and Process
Systems

+47 907 81 416



Sveinung Bekken

Product Manager, Dehumidifiers and
Drying Systems

+47 957 39 241



Odd-Anders Beckmann

Product Manager, Filter and Water
Treatment Systems

+47 906 15 402



Joachim Østberg

Service Manager

+47 916 36 167